

San Ace 150W

Splash Proof Centrifugal Fan

Features

Splash proof and dust resistant

- Protection class IP54* water and dust resistant performance.
- Maintains safe operation even in harsh environments.

Large air flow and high static pressure

- Maximum air flow : 3.83 m³/min
- Maximum static pressure : 390 Pa

Energy-saving design and Low noise

- Power consumption: 15.4 W
- Sound Pressure Level: 59 dB(A)



※ "IP54" is a protection specification for protection against water sprays and dust. It is based on IEC (International Electrotechnical Commission) and JIS (Japanese Industrial Standards) and specified as follows. Ingress of dust is not entirely prevented, but it must not enter in sufficient quantity to interfere with the satisfactory operation of the equipment; complete protection against contact. Water splashing against the enclosure from any direction shall have no harmful effect.

φ150mm × 35mm

Specifications

When our inlet nozzle [Option (Model : 109-1081)] is mounted.

Model No.	Rated Voltage [V]	Operating Voltage Range [V]	PWM Duty Cycle* [%]	Rated Current [A]	Rated Input [W]	Rated Speed [min ⁻¹]	Air Flow		Static Pressure		SPL [dB(A)]	Operating Temperature [°C]	Life Expectancy [h]
							[m ³ /min]	[CFM]	[Pa]	[inchH ₂ O]			
9W1TN48P1H01	48	36.0 to 55.2	100	0.32	15.4	3,800	3.83	135	390	1.57	59	-10 to +70	40,000

Fan does not rotate when PWM duty cycle is 0%.
Max input is 22W at rated voltage.

*PWM Frequency : 25kHz

Common Specifications

- Material Motor case: Aluminum(Black Painting), Impeller: Plastics (Flammability: UL94V-0)
- Life Expectancy Varies for each model
(L10: Survival rate: 90% at 60°C, rated voltage, and continuously run in a free air state)
- Motor Protection System Current blocking function and reverse polarity protection
- Dielectric Strength 50/60 Hz, 500VAC, 1 minute (between lead conductor and motor case)
- Sound Pressure Level (SPL) Expressed as the value at 1m from air inlet side
- Storage Temperature -30°C to +70°C (Non-Condensing)
- Lead Wire ⊕red ⊖black Sensor: yellow Control: brown
- Mass Approx.330g

San Ace 150W

Air Flow - Static Pressure Characteristics

- PWM Duty Cycle

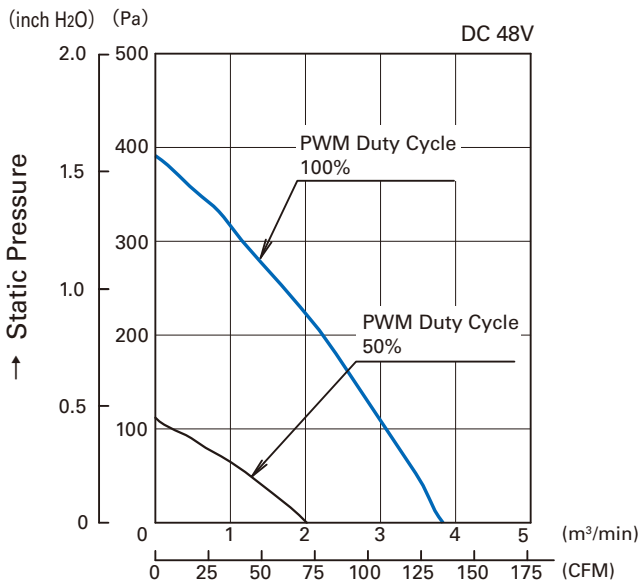

→ Air Flow
9W1TN48P1H01

- Operating Voltage Range

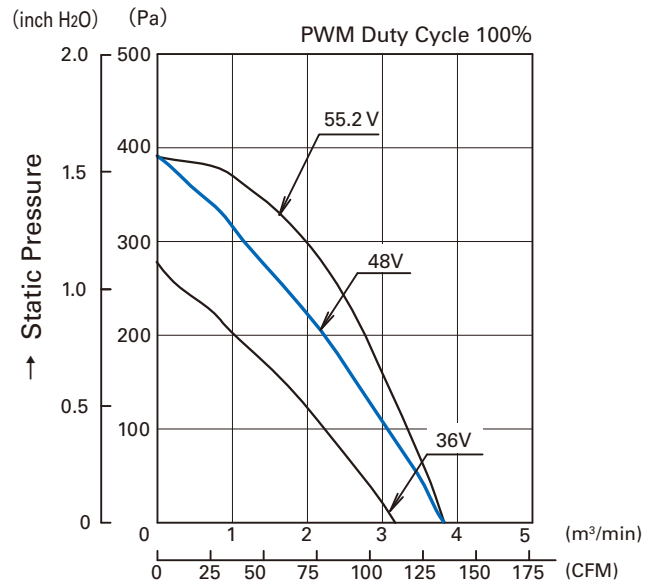

→ Air Flow
9W1TN48P1H01

PWM Duty - Speed Characteristics Example

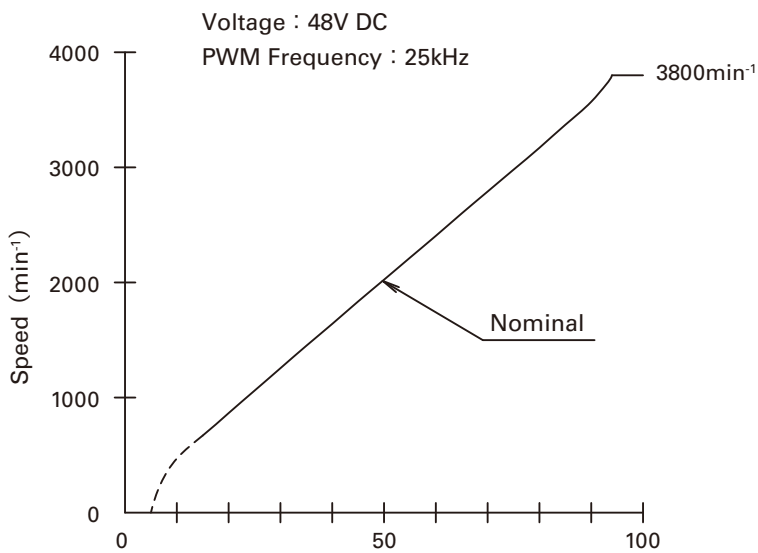

→ PWM Duty Cycle (%)
9W1TN48P1H01

PWM Input Signal Example

Input Signal Wave Form

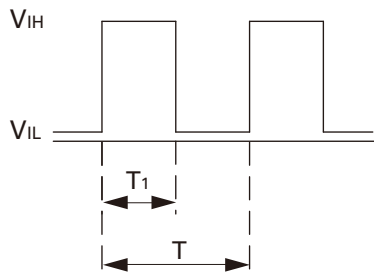

$V_{IH}=4.75V$ to $5.25V$

$V_{IL}=0V$ to $0.4V$

PWM Duty Cycle (%) = $\frac{T_1}{T} \times 100$

PWM Frequency 25 (kHz) = $\frac{1}{T}$

Source Current (I_{source}) : 2mA Max. at control voltage 0V

Sink Current (I_{sink}) : 1mA Max. at control voltage 5.25V

Control Terminal Voltage : 5.25V Max. (Open Circuit)

When the control lead wire is no connecting, the speed is the same speed as at 100% of PWM cycle.

This fan speed should be controlled by PWM input signal of either TTL input or open collector, drain input.

Connection Schematic

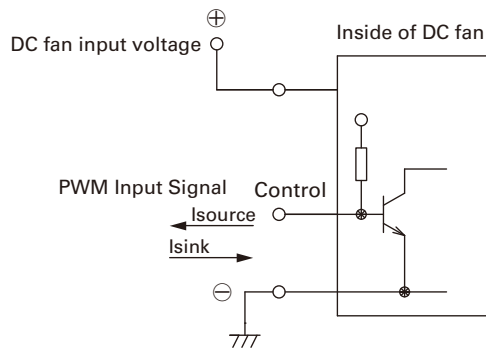

Specifications for Pulse Sensors

Output circuit : Open collector

$V_{CE}=+60V$ MAX
 $I_c=10mA$ MAX [$V_{OL}=V_{CE(SAT)}=0.8V$ MAX]

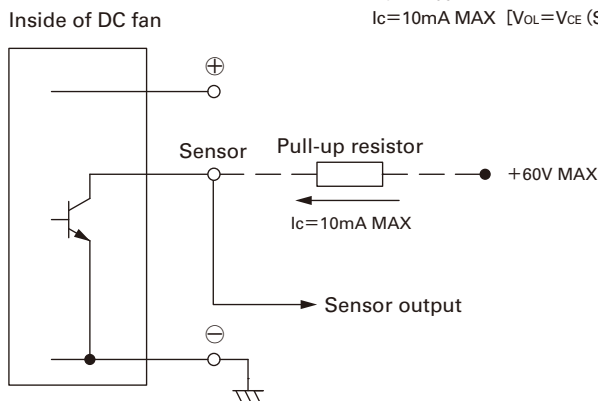

Output waveform (Need pull-up resistor)

In case of steady running

(One revolution)

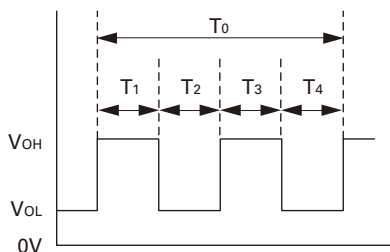

$T_{1\sim 4} \doteq (1/4) T_0$

$T_{1\sim 4} \doteq (1/4) T_0 = 60/4N$ (sec)

$N = \text{Fan speed (min}^{-1}\text{)}$

Dimensions (unit : mm)

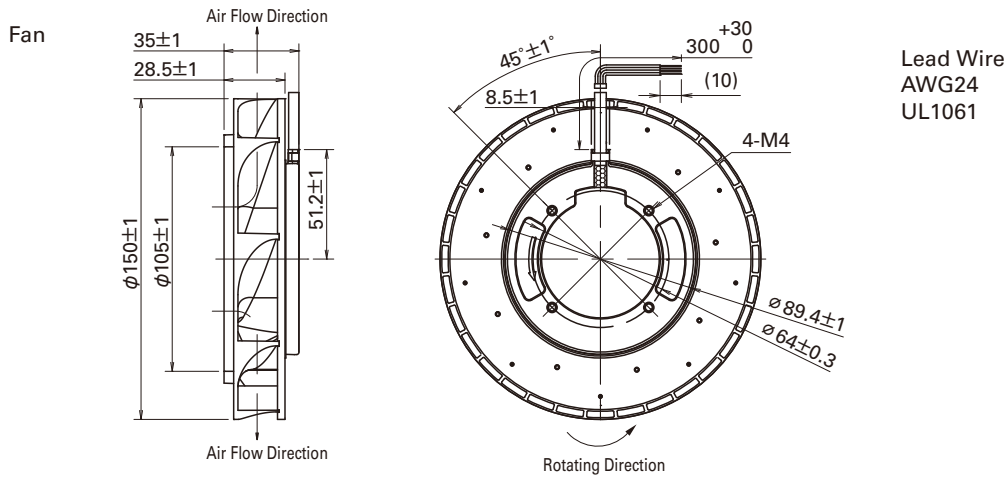

Inlet nozzle

(Model No. : 109-1081)

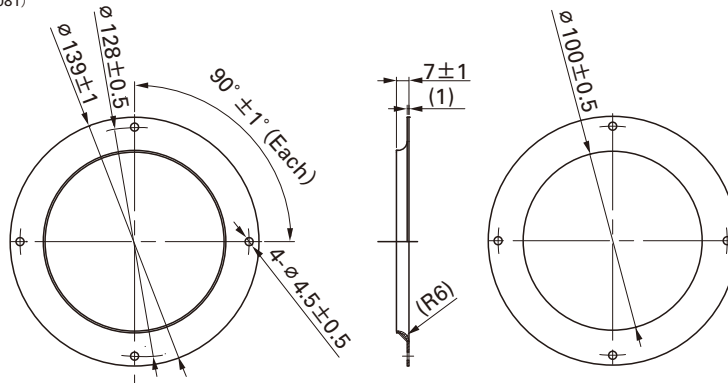

Inlet nozzle: Nozzle mounted in fan inlet side to adjust the flow of introduced air

Reference dimension of mounting holes and vent opening (unit : mm)

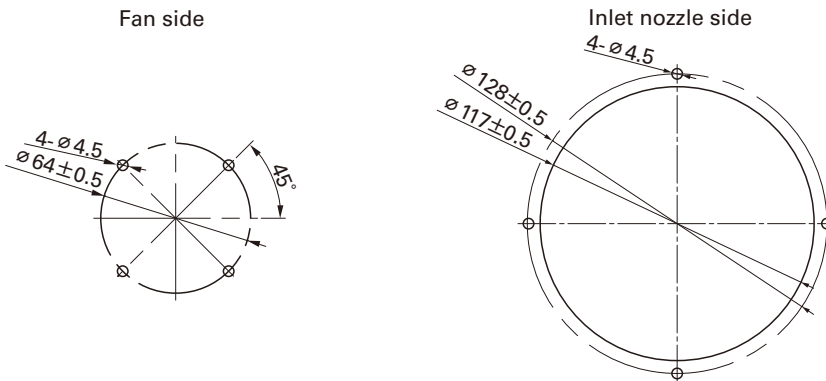

Reference diagram for mounting

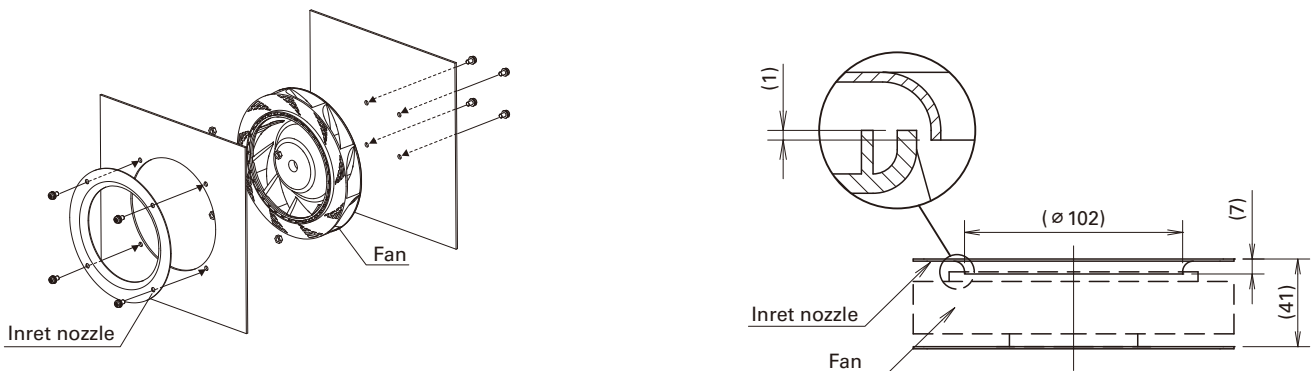

Screw length should be 4 mm or more but not exceeding 6 mm from fan edge face.

Notice

- The products shown in the catalog are subject to Japanese Export Control Law. Diversion contrary to the law of exporting country is prohibited.
- To protect against electrolytic corrosion that may occur in locations with strong electromagnetic noise, we provide fans that are unaffected by electrolytic corrosion.

SANYO DENKI CO., LTD. 1-15-1, Kita-otsuka, Toshima-ku, Tokyo 170-8451, Japan. PHONE :+ 81 3 3917 5151 Home Page: <http://www.sanyodenki.co.jp>