

FBA08A (80mm)

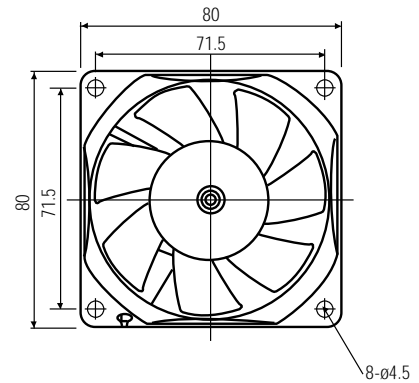

Housing with solid corner type is also available

CUT OUT

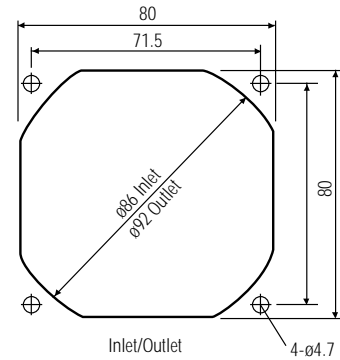

Features

- Operating Temperature: -10°C — +70°C (65% RH)
- Storage Temperature: -40°C — +75°C (65% RH)
- Bearing Type: Hydro Wave
- Connector Type: Plug-In

- Aerodynamic blade and venturi design
- Locked rotor protection and auto-start function
- Lower circuit noise by new IC
- Optional third lead wire signal (Locked rotor alarm sensor, 2PPR)
- Easy value-add access to lead wires via plug-in connector on housing

Basic Data (nominal at room temperature)

	Rated Voltage (V)	Operating Voltage (V)	Rated Current (mA)	Rated Input (W)	Nominal Speed (r/min)	Maximum Air Flow		Maximum Air Pressure		Noise (dB-A)
						(m3/min)	(CFM)	(mmH2O)	(Pa)	
FBA08A12L1A	12	7—13.8	68	0.82	1900	0.68	24.0	1.57	15.4	21.0
FBA08A12M1A	12	7—13.8	124	1.49	2450	0.91	32.1	2.51	24.6	28.0
FBA08A12H1A	12	7—13.8	173	2.08	2950	1.12	39.6	3.78	37.1	32.0
FBA08A12U1A	12	7—13.8	270	3.24	3450	1.33	46.9	4.8	47.0	38.2
FBA08A24L1A	24	14—27.6	54	1.30	1900	0.68	24.0	1.57	15.4	21.0
FBA08A24M1A	24	14—27.6	71	1.70	2450	0.91	32.1	2.51	24.6	28.0
FBA08A24H1A	24	14—27.6	105	2.52	2950	1.12	39.6	3.78	37.1	32.0

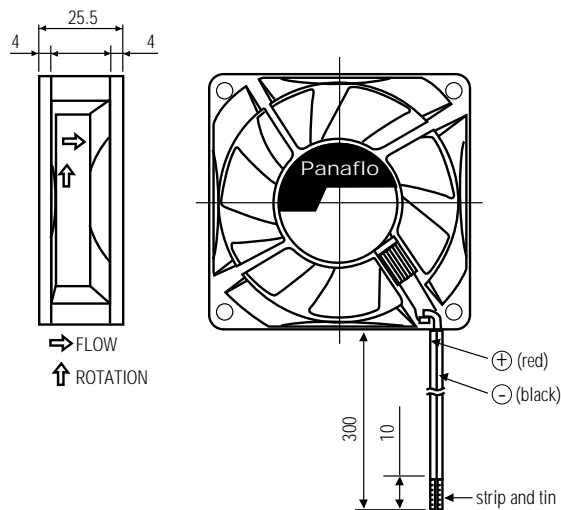

All dimensions in mm.

Lead Wire

All lead wires are 300mm in length \pm 15mm. (bare wire 10mm \pm 5mm.)

Housing and Fan Blade:
Plastic (PET, PBT, ABS)

Size

80.0 x 80.0 x 25.5
(3.15 x 3.15 x 1.00)

Weight

100 grams (3.53 ounces)

Case Quantity

100 per box

Conversion Factors

1 mm H₂O = 9.8 PA

1 m³/min = 35.313 CFM

FBA08A (80mm)

Characteristics

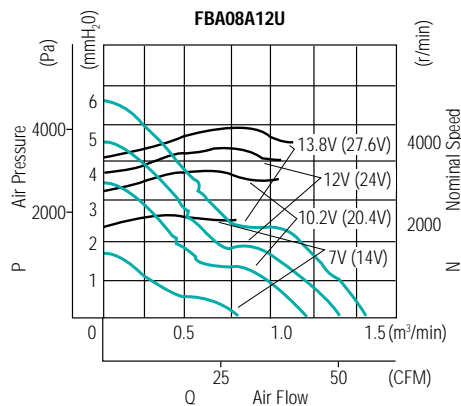
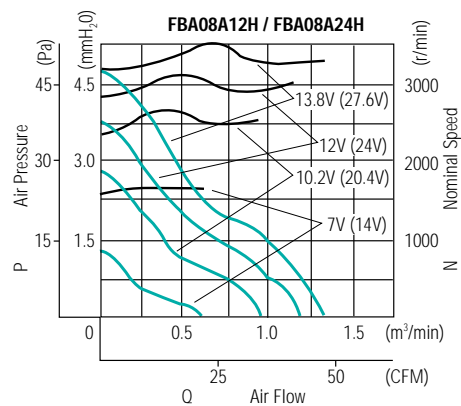
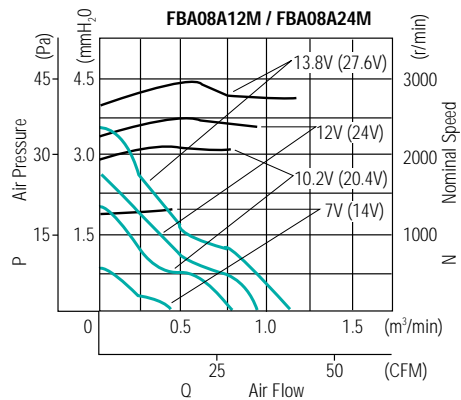
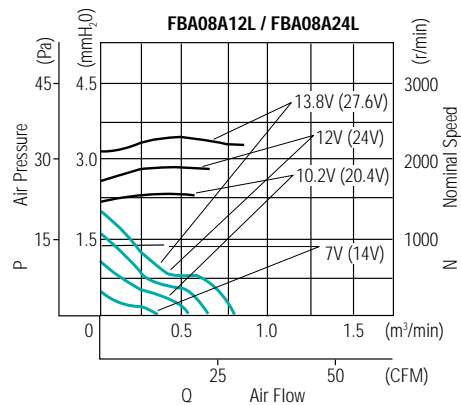

— P—Q
— N—Q