

max. 79 m³/h

DC Axial Fans

Series 8400 N 80 x 80 x 25 mm



Highlights:

- Ball bearings and sleeve bearings available.
- Some models suitable for use at high ambient temperatures to 85 °C.

General characteristics:

- Material: fiberglass-reinforced plastic. Impeller PA, housing PBT.
- Fully integrated electronic commutation.
- Protected against reverse polarity and blocking.
- Electrical connection via single leads AWG 24, TR 64. Stripped and tinned ends.
- Blowing over struts. Rotational direction CCW looking at rotor.
- Mass: 95 g.

Nominal Data	Air Flow		Nominal Voltage	Voltage Range	Noise	Sound Power	Sinter-Sleeve Bearings Ball Bearings	Power Input	Nominal Speed	Temperature Range	Service Life L ₁₀ (40 °C) ebm-papst Standard	Service Life L ₁₀ (T _{max}) ebm-papst Standard	Life expectancy L _{10Δ} (40 °C)	Curve	Specials
	m ³ /h	CFM													
8412 NGLE	33	19.4	12	8...15	12	3.5	□	0.5	1 500	-20...+85	80 000 / 27 500	160 000	160 000	1	/2
8412 NLE	33	19.4	12	8...15	17	3.7	■	0.3	1 500	-20...+85	80 000 / 27 500	160 000	160 000	1	
8412 NGMLE	45	26.5	12	8...15	19	3.9	□	0.9	2 050	-20...+80	80 000 / 32 500	160 000	160 000	2	/2
8412 NMLE	45	26.5	12	8...15	21	4.0	■	0.6	2 050	-20...+85	80 000 / 27 500	160 000	160 000	2	
8412 NGME	58	34.1	12	8...15	26	4.3	□	1.4	2 600	-20...+75	80 000 / 35 000	160 000	160 000	3	/2
8412 NME	58	34.1	12	8...15	27	4.4	■	1.0	2 600	-20...+75	80 000 / 35 000	160 000	160 000	3	
8412 NG	69	40.6	12	8...15	32	4.7	□	2.0	3 100	-20...+70	70 000 / 35 000	140 000	140 000	4	/2
8412 N	69	40.6	12	8...15	32	4.7	■	2.0	3 100	-20...+70	70 000 / 35 000	140 000	140 000	4	/2
8412 NH	79	46.5	12	8...13.2	37	5.0	■	2.2	3 600	-20...+70	70 000 / 35 000	140 000	140 000	5	/2;/12
8412 NH-217	79	46.5	12	8...15	37	5.0	■	2.4	3 600	-20...+70	70 000 / 35 000	140 000	140 000	5	
8414 NGL	33	19.4	24	18...28	12	3.5	□	0.7	1 500	-20...+70	80 000 / 40 000	160 000	160 000	1	/2
8414 NL	33	19.4	24	18...28	17	3.7	■	0.7	1 500	-20...+70	80 000 / 40 000	160 000	160 000	1	
8414 NGML	45	26.5	24	18...28	19	3.9	□	1.1	2 050	-20...+70	80 000 / 40 000	160 000	160 000	2	
8414 NML	45	26.5	24	18...28	21	4.0	■	1.1	2 050	-20...+70	80 000 / 40 000	160 000	160 000	2	
8414 NGM	58	34.1	24	18...28	26	4.3	□	1.4	2 600	-20...+70	80 000 / 40 000	160 000	160 000	3	/2
8414 NM	58	34.1	24	18...28	27	4.4	■	1.4	2 600	-20...+70	80 000 / 40 000	160 000	160 000	3	
8414 NG	69	40.6	24	18...28	32	4.7	□	2.0	3 100	-20...+70	70 000 / 35 000	140 000	140 000	4	/2
8414 N	69	40.6	24	18...28	32	4.7	■	2.0	3 100	-20...+70	70 000 / 35 000	140 000	140 000	4	/2
8414 NH	79	46.5	24	18...26	37	5.0	■	2.4	3 600	-20...+70	70 000 / 35 000	140 000	140 000	5	/2
8414 NH-221	79	46.5	24	18...28	37	5.0	■	2.4	3 600	-20...+70	70 000 / 35 000	140 000	140 000	5	
8418 N	69	40.6	48	36...56	32	4.7	■	2.0	3 100	-20...+70	70 000 / 35 000	140 000	140 000	4	

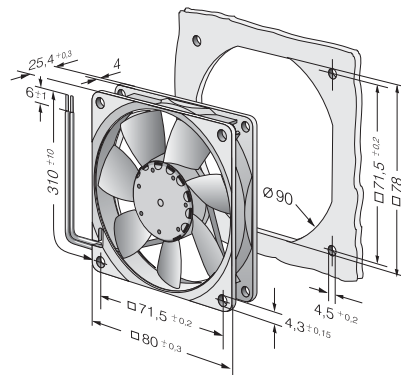
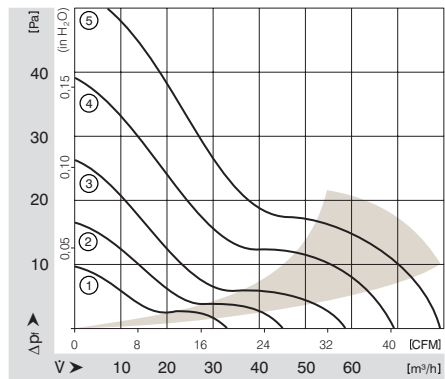

ebmpapst

