



8100 Series

Tubeaxial

80x80x38mm

- DC fans with electronically commutated external rotor motor. Fully integrated commutation electronics.
- With electronic protection against reverse polarity and blocking.
- Mounting from either face using four 4.3 mm holes.
- Fan housing and impeller of metal.
- Air exhaust over struts. Rotational direction CW looking at rotor.
- Electrical connection via 2 leads AWG 22, TR 64.
- UL, CSA, VDE approvals on some models, please contact application engineering.

Part Number	CFM @ 0	Volts	Voltage Range	Power (W)	dBA	Max Ambient Temp C	Wgt. (lbs)	Type Of Bearing	Features
8124K	35	24	18 to 30	3.0	39	72	0.94	Ball	Leads

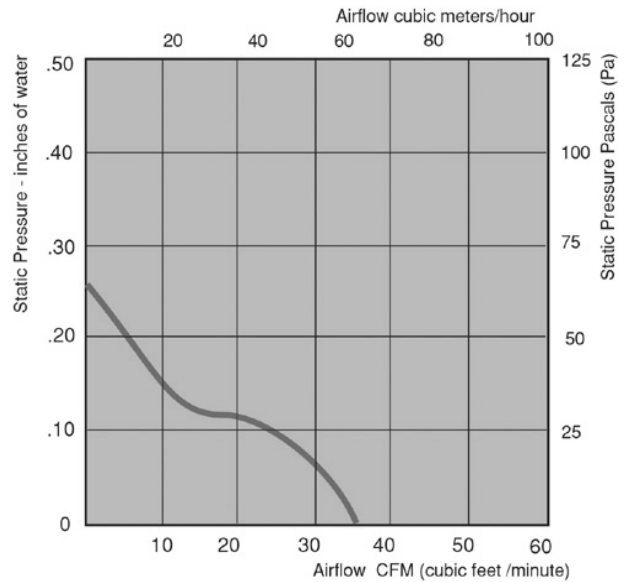
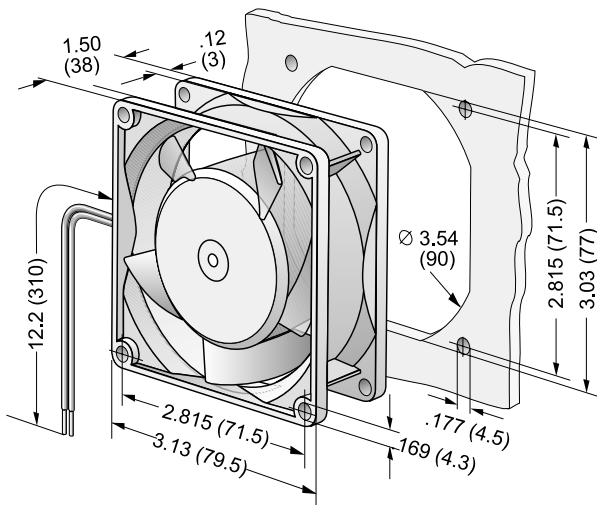

e-mail: sales@ebm.com • TEL: 860-674-1515 • FAX: 860-674-8536
 ebm Industries, Inc., 100 Hyde Road, Farmington, CT 06034 USA
 ebm Industries, Inc., 2003 © ebm Industries, Inc. reserves the right to change any specifications or data without notice