

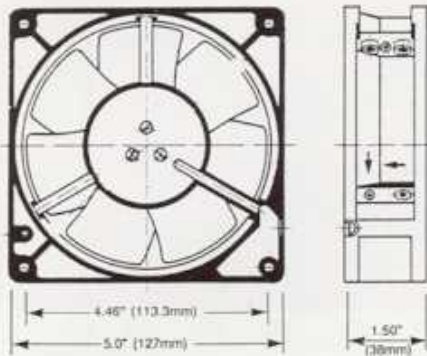

**W2G 115**  
**Brushless DC**  
 5" x 1-1/2"  
 (127mm x 38mm)

**ebm**   
 INDUSTRIES, INC.

**Dimensions**



**Air Performance**

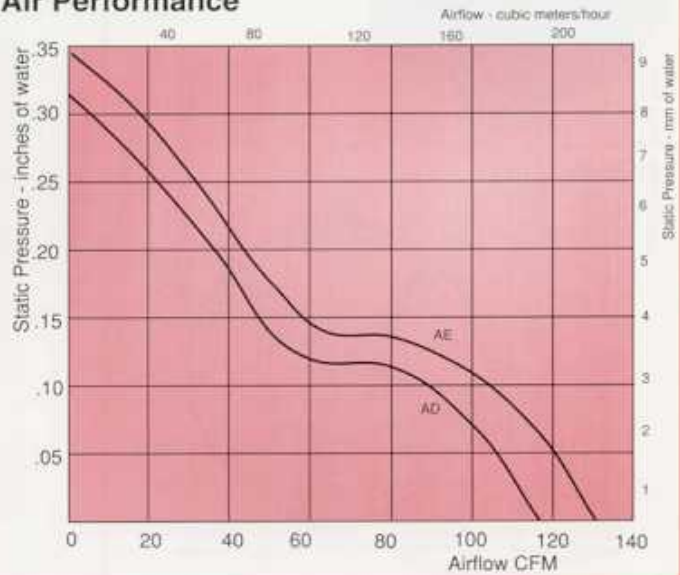

Ball Bearing Max. Temp. 72°C	DC		CFM	dBA	PSIL dB	Features	Approvals		
	Volts	Watts					UL	CSA	VDE
W2G115-AE53-13	12	5.9	130	48	41	Terminals	✓	✓	✓
W2G115-AE53-01	12	5.9	130	48	41	10.5" AWG 22 Leads	✓	✓	✓
W2G115-AE31-13	24	5.7	130	48	41	Terminals	✓	✓	✓
W2G115-AE31-01	24	5.7	130	48	41	10.5" AWG 22 Leads	✓	✓	✓
W2G115-AD15-13	12	4.5	118	44	36	Terminals	✓	✓	✓
W2G115-AD15-01	12	4.5	118	44	36	10.5" AWG 22 Leads	✓	✓	✓
W2G115-AD17-13	24	4.7	118	44	36	Terminals	✓	✓	✓
W2G115-AD17-01	24	4.7	118	44	36	10.5" AWG 22 Leads	✓	✓	✓
W2G115-AD19-01	48	4.6	118	44	36	10.5" AWG 22 Leads	✓	✓	✓

UL yellow card E54522, CSA file LR43145, VDE file 1375

**Construction, Mounting & Connection**

**Mounting:** From either face using four .185" (4.7mm) holes.  
**Weight:** 1.5 lbs. (.70kg)  
**Air Flow:** Struts on discharge.  
**Housing:** Aluminum.

**Connection:** Two polarized spade terminals .110" (2.8mm) wide, .020" (.51mm) thick and .33" (8.5mm) long on .295" (7.5mm) centers. Leads color coded, red(+), blue(-).  
**Option:** Special connectors.