

Slimline Axial Flow Fans

80mm 92mm 119mm

multicomp

80mm, 119mm



Features:

- Low cost, low noise, high pressure fans.
- Sleeve bearings.
- Rated plastic impellers.
- Supplied with 300mm, 22AWG lead wire.

80mm, 92mm, 119mm 'Slimline'



Features:

- Low cost slimline AC fans.
- Ball bearing.
- Aluminium frame with Rated plastic impeller.
- Supplied with a 330mm 24AWG lead wire.

Specifications:

Motor	: Reliable Shaded-Pole Motor Construction.
Frame	: Die-Cast aluminum housing painted black for moisture and corrosion resistance.
Impeller	: Injection moulded non-flammable black thermoplastic.
Bearing	: Precision, life-lubricated ball bearing system. Precision, oil-impregnated sintered sleeve bearing system.
Insulation	: Class B integral ground system rated at 120°C.
Insulation resistance	: 500MΩ minimum at 500V dc.
Dielectric strength	: 1500V ac for one minute.
Safety protection	: Impedence protected.
Operating temperature	: -10°C to +70°C.
Storage temperature	: -40°C to +80°C.
Operating voltage	: For 115V, ranged voltage from 85V to 125V. For 230V, ranged voltage from 185V to 245V.
Life expectancy	: >30,000 hours at 55°C.

multicomp

Slimline Axial Flow Fans

80mm 92mm 119mm



Product Guide:

Dimensions:

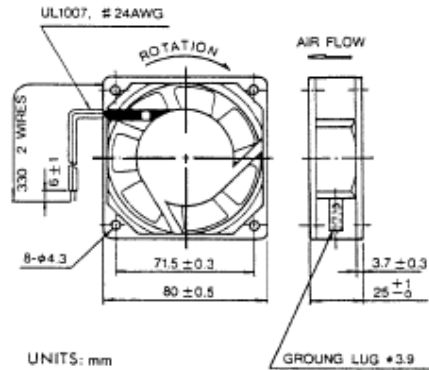

80 x 80 x 25mm

- 17 to 22 CFM
- 115V or 230V ac, 50/60Hz
- Reliable AC motor construction
- Impedance protection
- Precision Ball Bearing System
- 24AWG lead wire

Performance

HSL

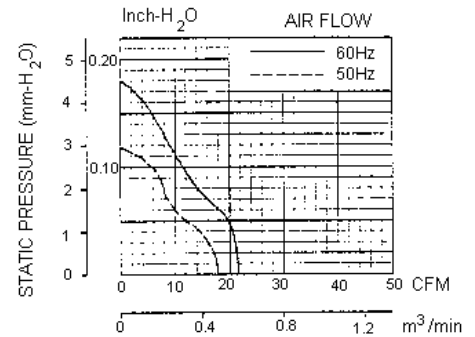

Dimensions:

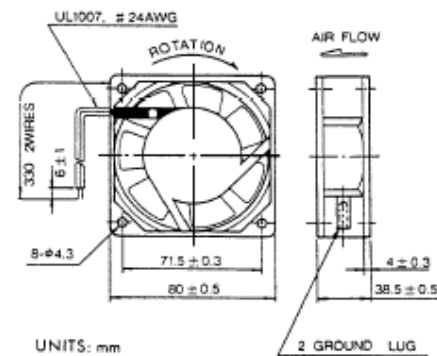

80 x 80 x 38mm

- 23 to 31 CFM
- 115V or 230V ac, 50/60Hz
- Reliable AC motor construction
- Impedance protection
- Lubricated Sintered Sleeve Bearing System
- 22AWG leadwire

Performance

HSL

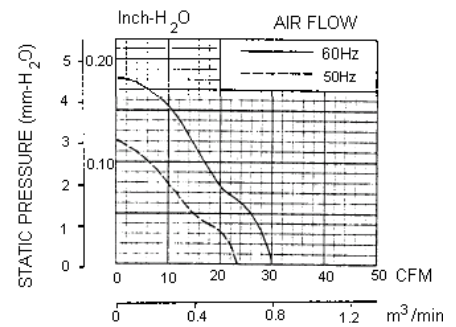

Dimensions:

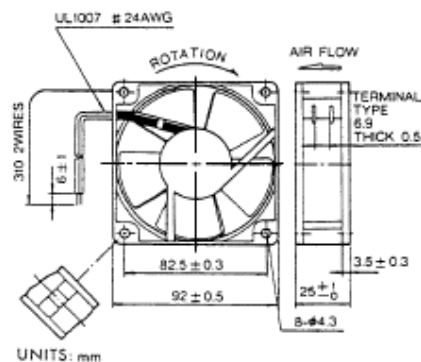

92 x 92 x 25mm

- 29 to 37 CFM
- 115V or 230V ac, 50/60Hz
- Reliable AC motor construction
- Precision Ball Bearing System
- Available with terminal type or leadwire type
- 24AWG leadwire

Performance

HST/HSL

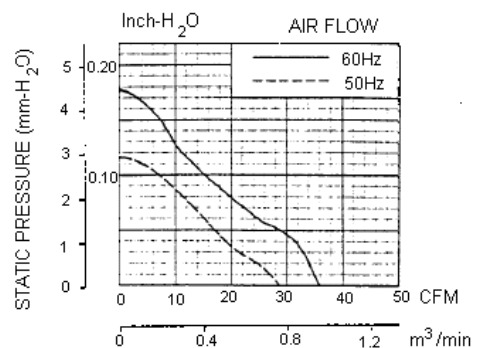

Slimline Axial Flow Fans

80mm 92mm 119mm



Plastic Guard is designed to ensure safe operation. Thermoplastic PBT Rating material.

PB - 08 for 80mm fan

PB - 09 for 92mm fan

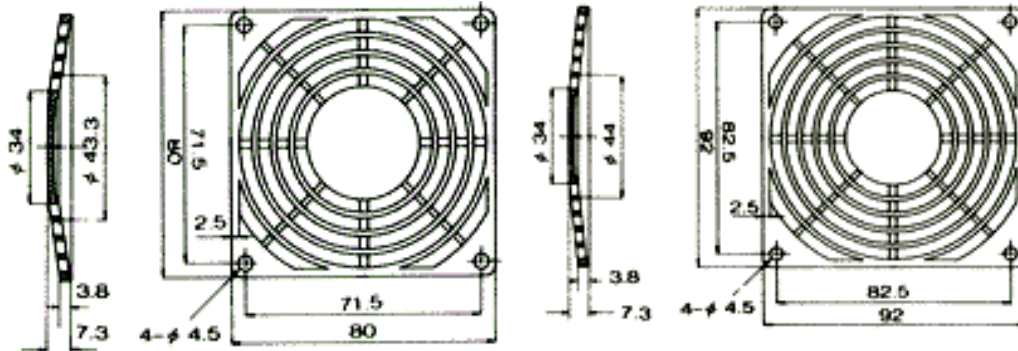

80mm, 119mm

Height	80		119		
Width	80		119		
Depth	38				
Type	80mm, Standard	119mm, Low Noise		119mm, Standard	119mm, Standard
Bearing Type*	SB				
Frequency (Hz)	50/60				
Current (A)	0.15/0.13	0.13/0.11	0.08/0.06	0.21/0.18	0.125/0.11
Power (Watts)	14/12	11/11	11	20/18	18
Speed (RPM)	2300/2750	2000/2200		2550/2900	
Air Flow	cu ft/min	23/30	70/76	85/105	107
	ltrs/sec	14.1	35.8	49.5	50.4
Static Pressure (Inch-H ₂ O)	0.12/0.18	0.08/0.12		0.25/0.30	
Noise dBA at 1m	31/35	36/38		43/48	50
Voltage (V ac)	115		230	115	230
Part Number	SF11580A/MC1083HSL	SP103A/MC1123LSL	DP203A/MC2123LSL	SP101A/MC1123HSL	DP201A/MC2123HSL

*SB = Sleeve Bearing

Dimensions : Millimetres (Unless Specified)



Slimline Axial Flow Fans

80mm 92mm 119mm



80mm, 92mm, 119mm 'Slimline'

Height	80		92		119	
Width	80		92		119	
Depth	25					
Type	80		92		119	
Bearing Type*	BB					
Frequency (Hz)	50/60					
Current (A)	0.07/0.07	0.12/0.11	0.07/0.06	0.19/0.18	0.09/0.09	
Power (Watts)	14/13.5	13/12	14.5/14	19/18		
Speed (RPM)	2450/2900	2350/2850			2150/2300	
Air Flow	cu ft/min	18/22	30/37		66/78	
	ltrs/sec	10.3	17.4		36.7	
Static Pressure (Inch-H₂O)	0.13/0.19			0.14/0.16		
Noise dBA at 1m	34	37/40		44/46		
Voltage (V ac)	230	115	230	115	230	
Part Number	SF23080AT/ MC2082HBL	SF11592A/ MC1092HBL	SF23092A/ MC2092HBL	SP101AT/ MC1122HBL	DP201AT/ MC2122HBL	

*BB = Ball Bearing

Dimensions : Millimetres (Unless Specified)



Slimline Axial Flow Fans

80mm 92mm 119mm

Notes:

International Sales Offices:

**AUSTRALIA – Farnell InOne**

Tel No: ++ 61 2 9645 8888
Fax No: ++ 61 2 9644 7898

**FINLAND – Farnell InOne**

Tel No: ++ 358 9 560 7780
Fax No: ++ 358 9 345 5411

**NETHERLANDS – Farnell InOne**

Tel No: ++ 31 30 241 7373
Fax No: ++ 31 30 241 7333

**SWITZERLAND – Farnell InOne**

Tel No: ++ 41 1 204 64 64
Fax No: ++ 41 1 204 64 54

**AUSTRIA – Farnell InOne**

Tel No: ++ 43 662 2180 680
Fax No: ++ 43 662 2180 670

**FRANCE – Farnell InOne**

Tel No: ++ 49 89 61 39 39 39
Fax No: ++ 33 474 68 99 90

**NEW ZEALAND – Farnell InOne**

Tel No: ++ 64 9 357 0646
Fax No: ++ 64 9 357 0656

**UK – Farnell InOne**

Tel No: ++ 44 8701 200 200
Fax No: ++ 44 8701 200 201

**BELGIUM – Farnell InOne**

Tel No: ++ 32 3 475 2810
Fax No: ++ 32 3 227 3648

**GERMANY – Farnell InOne**

Tel No: ++ 49 89 61 39 39 39
Fax No: ++ 49 89 613 59 01

**NORWAY – Farnell InOne**

Tel No: ++ 45 44 53 66 66
Fax No: ++ 45 44 53 66 02

**UK – BuckHickman InOne**

++ 44 8450 510 150
++ 44 8450 510 130

**BRAZIL – Farnell-Newark InOne**

Tel No: ++ 55 11 4066 9400
Fax No: ++ 55 11 4066 9410

**HONG KONG – Farnell-Newark InOne**

Tel No: ++ 852 2268 9888
Fax No: ++ 852 2268 9899

**PORTUGAL – Farnell InOne**

Tel No: ++ 34 93 475 8804
Fax No: ++ 34 93 474 5288

**UK – CPC**

++ 44 8701 202 530
++ 44 8701 202 531

**CHINA – Farnell-Newark InOne**

Tel No: ++86 10 6238 5152
Fax No: ++86 10 6238 5022

**IRELAND – Farnell InOne**

Tel No: ++ 353 1 830 9277
Fax No: ++ 353 1 830 9016

**SINGAPORE – Farnell-Newark InOne**

Tel No: ++ 65 6788 0200
Fax No: ++ 65 6788 0300

**EXPORT – Farnell InOne**

Tel No: ++ 44 8701 200 208
Fax No: ++ 44 8701 200 209

For enquiries from all other markets

**DENMARK – Farnell InOne**

Tel No: ++ 45 44 53 66 44
Fax No: ++ 45 44 53 66 06

**ITALY – Farnell InOne**

Tel No: ++ 39 02 93 995 200
Fax No: ++ 39 02 93 995 300

**SPAIN – Farnell InOne**

Tel No: ++ 34 93 475 8805
Fax No: ++ 34 93 474 5107

**ESTONIA – Farnell InOne**

Tel No: ++ 358 9 560 7780
Fax No: ++ 358 9 345 5411

**MALAYSIA – Farnell-Newark InOne**

Tel No: ++ 60 3 7873 8000
Fax No: ++ 60 3 7873 7000

**SWEDEN – Farnell InOne**

Tel No: ++ 46 8 730 50 00
Fax No: ++ 46 8 83 52 62

<http://www.farnellinone.com>

<http://www.buckhickmaninone.com>

<http://www.cpc.co.uk>

Disclaimer This data sheet and its contents (the "Information") belong to the Premier Farnell Group (the "Group") or are licensed to it. No licence is granted for the use of it other than for information purposes in connection with the products to which it relates. No licence of any intellectual property rights is granted. The Information is subject to change without notice and replaces all data sheets previously supplied. The Information supplied is believed to be accurate but the Group assumes no responsibility for its accuracy or completeness, any error in or omission from it or for any use made of it. Users of this data sheet should check for themselves the Information and the suitability of the products for their purpose and not make any assumptions based on information included or omitted. Liability for loss or damage resulting from any reliance on the Information or use of it (including liability resulting from negligence or where the Group was aware of the possibility of such loss or damage arising) is excluded. This will not operate to limit or restrict the Group's liability for death or personal injury resulting from its negligence. Multicomp is the registered trademark of the Group. © Premier Farnell plc 2004.