



ALL RIGHTS RESERVED. NO PORTION OF THIS PUBLICATION, WHETHER IN WHOLE OR IN PART CAN BE REPRODUCED WITHOUT THE EXPRESS WRITTEN CONSENT OF SPC TECHNOLOGY.

SPC-F005.DWG

REVISIONS

DOC. NO. SPC-F005 \* Effective: 7/8/02 \* DCP No: 1398

DCP #	REV	DESCRIPTION	DRAWN	DATE	CHECKD	DATE	APPRVD	DATE
1993	A	Released	JN	04/25/09	JWM	04/25/09	JWM	04/25/09

MATERIAL

- 2-1. Frame : Thermoplastic PBT of UL 94V-0
- 2-2. Impeller : Thermoplastic PBT of UL 94V-0
- 2-3. Bobbin : Thermoplastic PBT of UL 94V-0
- 2-4. Lead Wire : UL1571,28 awg, +RED, -BLACK

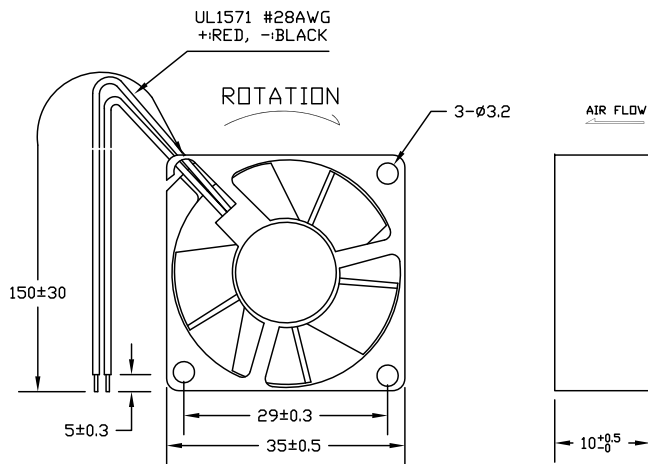

- 1. Air Flow Direction: Toward label side.
- 2. Best Mounting Direction: Any orientation.

Units:mm



DISCLAIMER:  
ALL STATEMENTS AND TECHNICAL INFORMATION CONTAINED HEREIN ARE BASED UPON INFORMATION AND/OR TESTS WE BELIEVE TO BE ACCURATE AND RELIABLE. SINCE CONDITIONS OF USE ARE BEYOND OUR CONTROL, THE USER SHALL DETERMINE THE SUITABILITY OF THE PRODUCT FOR THE INTENDED USE AND ASSUME ALL RISK AND LIABILITY WHATSOEVER IN CONNECTION THEREWITH.

TOLERANCES:  
**UNLESS OTHERWISE SPECIFIED, DIMENSIONS ARE FOR REFERENCE PURPOSES ONLY.**

DRAWN BY:	DATE:
Jason Nash	04/25/09
CHECKED BY:	DATE:
Jeff McVicker	04/25/09
APPROVED BY:	DATE:
Jeff McVicker	04/25/09

DRAWING TITLE:			
Axial Fan; Current Type:DC			
SIZE	DWG. NO.	ELECTRONIC FILE	REV
A	MC32902	71P8680.dwg	A
SCALE:	U.O.M.: INCHES [mm]	SHEET: 1 OF 4	
NTS			

## CHARACTERISTICS

- |                                 |   |                                                                                                                                                                                                |
|---------------------------------|---|------------------------------------------------------------------------------------------------------------------------------------------------------------------------------------------------|
| 1. Motor Design                 | : | Patented single-coil DC brushless 8 pole motor design.                                                                                                                                         |
| 2. Insulation Resistance        | : | More than 500 Megohms minimum at 500 VDC.                                                                                                                                                      |
| 3. Dielectric Strength          | : | Applied AC 500V for a minute or AC 600V for 2 sec.between housing and lead wire                                                                                                                |
| 4. Input power, Current & Speed | : | Measured after continuous 10 minute operation at rated voltage in clean air, and at ambient temperature of 25°C                                                                                |
| 5. Noise Level                  | : | Measured in a semi-anechoic chamber<br>with background noise level below 15<br>dB(A). The fan is running in free air with the<br>microphone at a distance of one meter<br>from the fan intake. |
| 6. Tolerance                    | : | ±15% on rated power and current.                                                                                                                                                               |
| 7. Air Performance              | : | Measured by a double chamber. The values<br>are recorded when the fan speed has stabilized<br>at rated voltage.                                                                                |



ALL RIGHTS RESERVED. NO PORTION OF THIS PUBLICATION, WHETHER IN WHOLE OR IN PART CAN BE REPRODUCED WITHOUT THE EXPRESS WRITTEN CONSENT OF SPC TECHNOLOGY.

SIZE DWG. NO.

A

MC32902

ELECTRONIC FILE

71P8680.dwg

REV

A

SPC-F005.DWG

DOC. NO. SPC-F005 \* Effective: 7/8/02 \* DCP No: 1398

SCALE: NTS

U.O.M.: Millimeters

SHEET: 2 OF 4

### PERFORMANCE CURVES

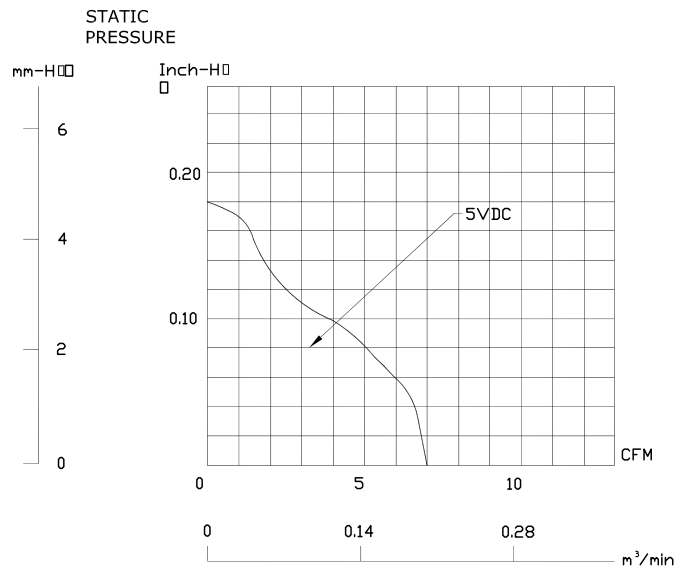

ALL RIGHTS RESERVED. NO PORTION OF THIS PUBLICATION, WHETHER IN WHOLE OR IN PART CAN BE REPRODUCED WITHOUT THE EXPRESS WRITTEN CONSENT OF SPC TECHNOLOGY.

SIZE DWG. NO.

A

MC32902

ELECTRONIC FILE

71P8680.dwg

REV

A

SPC-F005.DWG

DOC. NO. SPC-F005 \* Effective: 7/8/02 \* DCP No: 1398

SCALE: NTS

U.O.M.: Millimeters

SHEET: 3 OF 4

### SPECIFICATIONS

1-1. Rated Voltage	:	5 VAC
1-2. Operating Voltage Range	:	3~6 VAC
1-3. Starting Voltage	:	3 VDC (25 deg. C POWER ON/OFF)
1-4. Rated Speed	:	9500 RPM $\pm$ 20%
1-5. Air Delivery	:	7 CFM
1-6. Static Pressure	:	0.18 Inch-H <sub>2</sub> O
1-7. Rated Current	:	150 mA
1-8. Rated Power	:	0.8 WATTS
1-9. Noise Level	:	28 dB(A)
1-10. Direction of Rotation	:	Counter-clockwise viewed from front of fan blade
1-11. Operating Temperature	:	-10 to +70 deg.C
1-12. Storage Temperature	:	-40 to +70 deg.C
1-13. Bearing System	:	Vapo bearing system
1-14. Weight	:	10.5g
1-15. Safety	:	UL/CUR Approvals



ALL RIGHTS RESERVED. NO PORTION OF THIS PUBLICATION, WHETHER IN WHOLE OR IN PART CAN BE REPRODUCED WITHOUT THE EXPRESS WRITTEN CONSENT OF SPC TECHNOLOGY.

SIZE DWG. NO.

A

MC32902

ELECTRONIC FILE

71P8680.dwg

REV

A

SPC-F005.DWG

DOC. NO. SPC-F005 \* Effective: 7/8/02 \* DCP No: 1398

SCALE: NTS

U.O.M.: Millimeters

SHEET: 4 OF 4