

# DC 9225



**SIZE :**

92x92x25mm (3.62"x3.62"x0.98")

**CONSTRUCTION :**

Glass fiber reinforced plastic:  
Impeller and housing PBT are UL 94V-0 rating

**OPERATING TEMPERATURE :**

Ball bearing - 30°C to +75°C  
Sleeve bearing - 10°C to +70°C

**INSULATION RESISTANCE :**

10meg Ohm min. at 500 VDC  
(between frame and terminal)

**DIELECTRIC STRENGTH :**

5mA max. at 500 VAC 60Hz one minute  
(between frame and terminal)

**FUNCTION :**

frequency generator or rotation detection signal option

**WEIGHT :**

120 grams

## Specifications

Specifications are subject to change without notice

MODEL NO.	BEARING	RATED VOLTAGE	OPERATING VOLTAGE RANGE	RATED CURRENT	RATED INPUT POWER	SPEED R.P.M.	MAX. AIR FLOW		MAX. AIR PRESSURE		NOISE dB-A
		VDC	V	A	W		m <sup>3</sup> /min	CFM	mmH <sub>2</sub> O	IN H <sub>2</sub> O	
BP922512L	Ball	12	10.2-13.8	0.16	1.92	2000	1.174	41.50	2.30	0.091	28
SP922512L	Sleeve										
BP922524L	Ball	24	20.4-27.6	0.10	2.40	2000	1.174	41.50	2.30	0.091	28
SP922524L	Sleeve										
BP922512M	Ball	12	10.2-13.8	0.20	2.40	2500	1.429	50.50	3.50	0.138	34
SP922512M	Sleeve										
BP922524M	Ball	24	20.4-27.6	0.14	3.36	2500	1.429	50.50	3.50	0.138	34
SP922524M	Sleeve										
BP922512H	Ball	12	10.2-13.8	0.32	3.84	3000	1.661	58.70	4.30	0.169	38
SP922512H	Sleeve										
BP922524H	Ball	24	20.4-27.6	0.18	4.32	3000	1.661	58.70	4.30	0.169	38
SP922524H	Sleeve										

### Dimensions (mm)

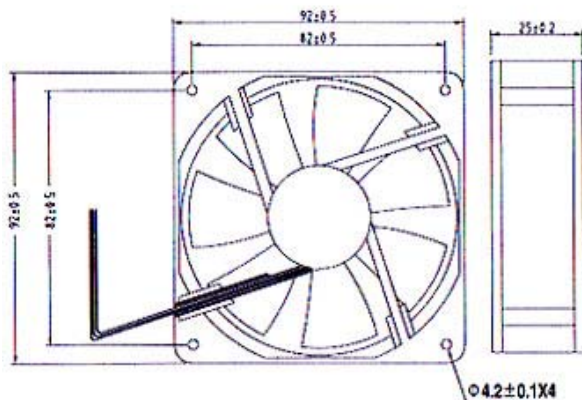

### Performance Curve

