

# 7200N Series

Tubeaxial

Ø 150x55mm



- DC fans with electronically commutated external rotor motor. Fully integrated commutation electronics.
- With electronic protection against reverse polarity and blocking.
- Metal fan housing. Impeller of fiberglass reinforced plastic PA.
- Mounting from either face using two 4.3 mm holes.
- Air exhaust over struts. Rotational direction CCW looking at rotor.
- Electrical connection via 2 leads AWG 22, TR 64. Stripped and tinned ends. Housing ground lug for screw M4.
- UL, CSA, VDE approvals on some models, please contact application engineering.

Part Number	Curve	CFM @ 0	VDC	Volt. Range	Power (W)	dBA	Max Amb. Temp C	Bearing Type	Features	Wgt. (lbs)
7212N	1	211.9	12	6 to 15	12.0	50	72	Ball	Leads	1.60
7214N	1	211.9	24	12 to 30	12.0	50	72	Ball	Leads	1.60
7218N	1	211.9	48	24 to 60	12.0	50	72	Ball	Leads	1.60

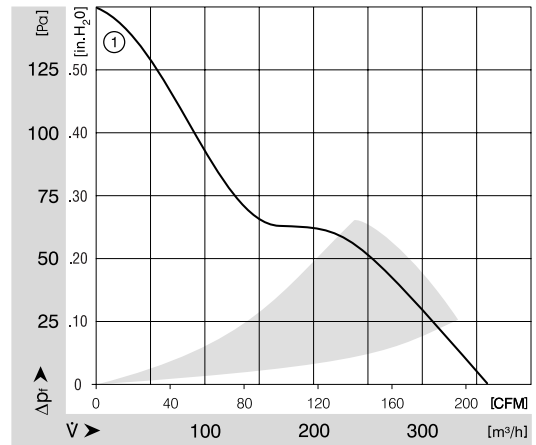
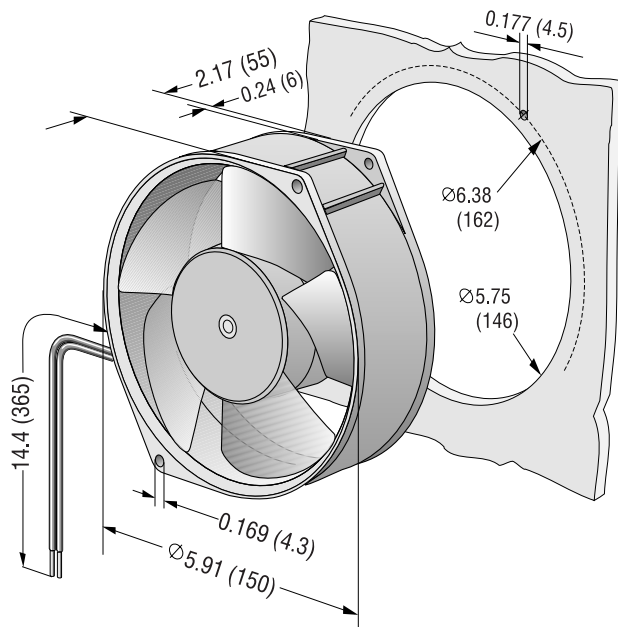

**ebmpapst**

e-mail: [sales@us.ebmpapst.com](mailto:sales@us.ebmpapst.com) · TEL: 860-674-1515 · FAX: 860-674-8536

ebm-papst Inc., 100 Hyde Road, Farmington, CT 06034 USA

ebm-papst Inc., 2006 © ebm-papst Inc. reserves the right to change any specifications or data without notice