

COOLING SYSTEM

# San Ace

Products Information

2006  
ver.2

SANYO DENKI



# C O N T E N T S

---

**Technical Material** ..... p.3

---

**Product Guide**

**Instruction Manual for Fan** ..... p.20

**Part Numbering System** ..... p.22

---

**DC Fans** ..... p.35

---

**Thermal Speed Controlled Fans** ..... p.97

---

**Splash Proof Fans** ..... p.111

---

**Oil Proof Fans** ..... p.137

---

**Long Life Fans** ..... p.145

---

**Blowers** ..... p.165

---

**Centrifugal Fans** ..... p.187

---

**CPU Coolers • Liquid Cooling Solution Systems** ··· p.191

---

**AC Fans** ..... p.223

---

**Option** ..... p.249

---

**Model No. index** ..... p.261

---

**Overseas Sales Network** ..... p.268

---





# TECHNICAL MATERIAL

# Overview and characteristics of fan

## Overview

Fan motor is widely used to extend life of your system by cooling off heat of the system that many electrical components are mounted in a very high density and dissipating heat. Since we Sanyo Denki developed "San Ace" which is the first AC fan in Japan in 1965, we have increased fan motor lineup until now meeting customer's needs rapidly based on our tremendous career. We Sanyo Denki will continue to develop new fans with lower noise, downsizing, low profile and higher efficiency.

## Characteristics

We can roughly divide fan into two types which are AC and DC.

### AC fans

Sanyo Denki succeeded in the mass-production of AC fans in 1965. Sanyo Denki was the first Japanese manufacturer to have succeeded at this.

- High performance
- High reliability
- Safety

### DC fans

Sanyo Denki succeeded in the mass-production of DC fans in 1982.

- High performance
- Low power consumption
- Low vibration
- Low leakage of flux
- High reliability

Sanyo Denki currently has a wider variety of products like Long Life Fan, CPU cooler, Splash Proof Fan, and Oil Proof Fan etc to meet all customer needs.

# Guideline in selecting a fan

## How to select an appropriate fan

The following example is a guideline regarding how to select an appropriate fan for cooling your system

### 1. Determining of your system specifications and conditions

Determine the temperature rise inside your system and obtain the total heating value inside your system on the basis of its inputs and outputs.

Example

V : Total heating value of your system (W) =100 (W)  
 $\Delta T$  : Inside temperature rise (K) =15 (K)

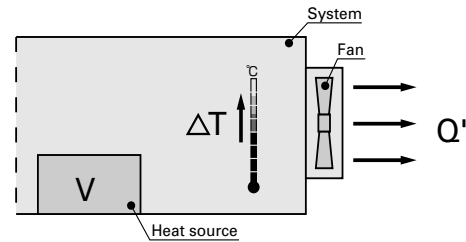

### 2. Calculating the Required Air flow for Cooling

After the equipment specifications and conditions of your system have been determined, calculate required air flow to meet the conditions.

(Note that the formula shown below only applies when the heat radiation is performed only by cooling air from the fan.)

Example

Q': Motion air flow (m<sup>3</sup>/min.)

$$Q' = \frac{V}{20\Delta T} = \frac{100 \text{ (W)}}{20 \times 15 \text{ (K)}} \approx 0.33 \text{ (m}^3/\text{min)}$$

### 3. Selecting the Fan

After the motion air flow has been calculated, select an appropriate fan motor based on the value.

The motion air flow when the fan motor is actually mounted in your system can be obtained using the air flow-static pressure characteristics curve and system impedance.

However, the system impedance cannot be measured without a measuring equipment, so fan with 1.5 to 2 times higher air flow than the actual Max air flow should be selected (operating air flow is one-third to two-thirds of maximum air flow).

Example

Q: Maximum air flow (m<sup>3</sup>/min.)

$$Q' = Q \times 2/3$$

$$Q = Q' \times 3/2 = 0.33 \times 3/2 \approx 0.5 \text{ (m}^3/\text{min)}$$

Next, In case that you select a fan having an air flow of 0.5 (m<sup>3</sup>/min.) or more and a appropriate size for the space inside your system.

For example, If you need a fan of 60mm square, 25mm thickness and 12V, you should select is 109R0612H402 (maximum air flow = 0.53m<sup>3</sup>/min.).

### 4. Confirming the Selected Fan

Calculate the temperature rise inside your sysetem when your sysetem having 100 (W) of total heating value is forcefully cooled down by a 109R0612H402 fan.

Example

$$Q' = Q \times 2/3 = 0.53 \times 2/3 \approx 0.353 \text{ (m}^3/\text{min)}$$

$$\Delta T = V / 20Q' = 100 \text{ (W)} / 20 \times 0.353 \text{ (m}^3/\text{min)} \approx 14.2 \text{ (K)}$$

From the above, the temperature rise inside your system is calculated as 14.2(K).

Since the value obtained from the above equation is only a rough target, final fan selection should be based on your actual installation test.

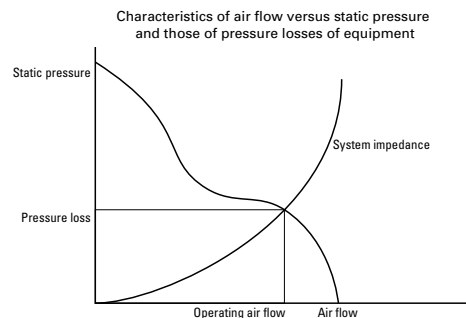

# Characteristics calculation method and description

## Reliability and life

A fan motor generally cools itself as well. The temperature rise of the motor is relatively low and the temperature rise of the grease in the bearings is also low, so expected life is longer than general some other motors. Since the service life of bearings is a theoretical value that applies when they are ideally lubricated, the life of lubricant can be regarded as expected life of the fan. The expected life of an AC fan used at an ambient temperature 60°C is 25,000 hours. The BLDC fan consumes less power and its temperature rise of bearing is very low, thus its expected life is 40,000 hours at an ambient temperature of 60°C. Sanyo Denki also has a line-up of Long Life Fans that has

200,000 hours life and 100,000 hours life at an ambient temperature 60°C with an even more enhanced structure and material. The table below indicates the relationship between ambient temperature and expected life estimated on the basis of our life tests and same other tests conducted by Sanyo Denki. (The survival rate is 90%.) An accelerated life test is conducted on the basis of the concept that the expected life halves as the ambient temperature rises by about 15°C (within the operating temperature range of lubricant.)

### Expected life of DC fans

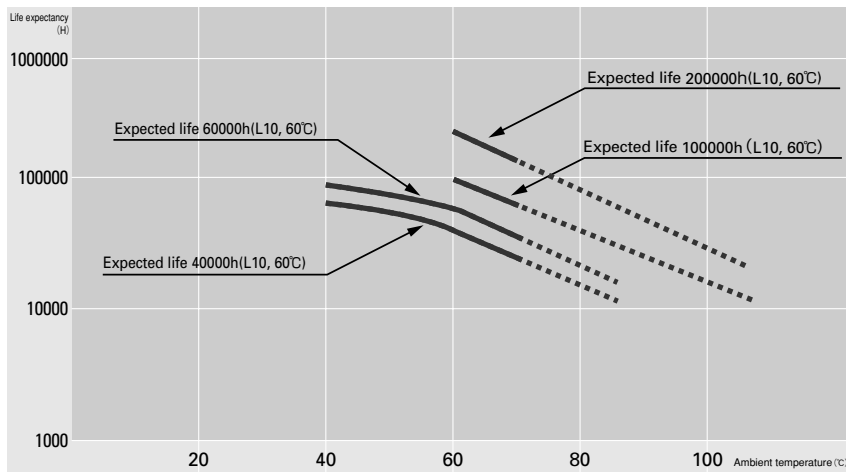

Rated voltage, continuous operation, free air, survival rate of 90%

### Expected life of AC fans

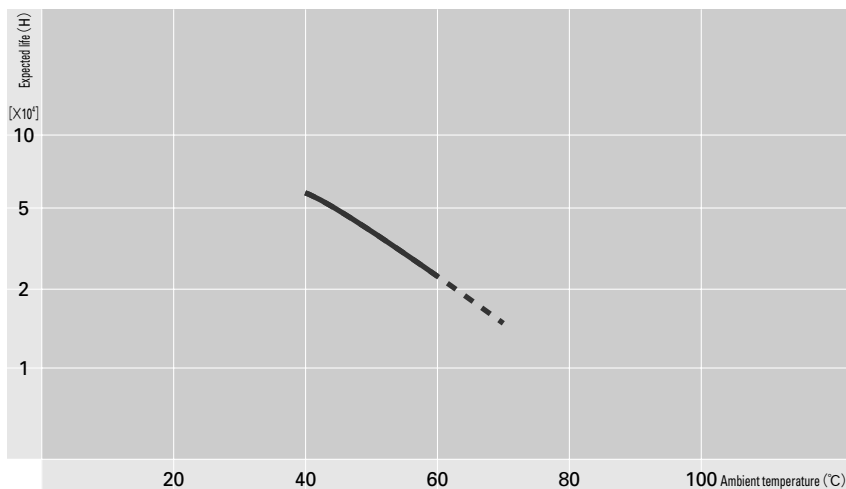

Rated voltage, continuous running, free air, survival rate of 90%

## Noise characteristics

Noise is average value that measured at 1 meter away from air intake side of fan that is suspended on special frame in anechoic chamber (as per JIS B 8330).

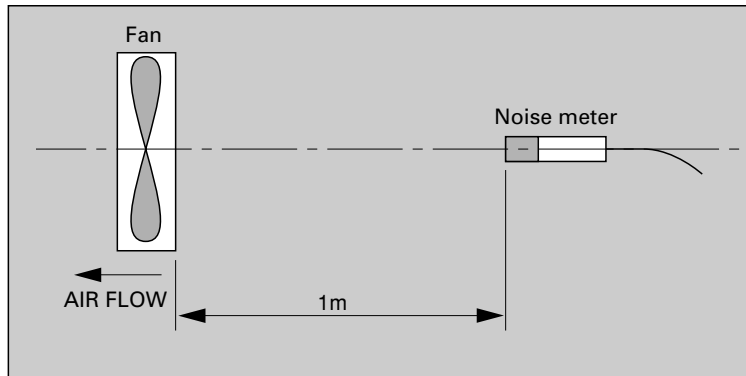

## General specifications

### Insulation resistance

10M $\Omega$  or more at 500 VDC megger (between the lead conductor and frame).

### Storage temperature range

-30 $^{\circ}$ C to +70 $^{\circ}$ C (Non-condensing).

# Characteristics calculation procedure and description

## Measuring air flow and static pressure

It is very difficult to measure air flow and static pressure. In fact, the performance curve may vary greatly according to the type of measuring equipment.

The commonly-used type of measuring equipment is a wind tunnel using a Pitot tube. Sanyo Denki uses a very precise method using double chamber equipped with many nozzles.

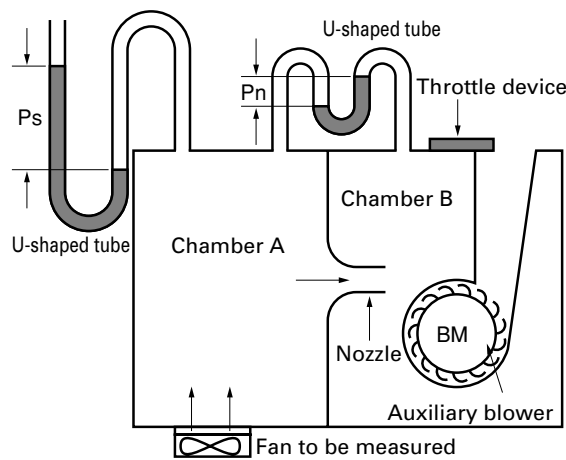

Double chamber measuring equipment

$$Q = 60A\bar{v} \text{ (A)}$$

where

Q = air flow (m<sup>3</sup>/min)

A = cross sectional area of nozzle =  $\frac{\pi}{4}D^2$  (m<sup>2</sup>)

D = nozzle diameter

$\bar{v}$  = average air flow velocity of nozzle =  $\sqrt{2g \frac{Pn}{\gamma}}$  (m/sec)

$\gamma$  : Air specific gravity (kg/m<sup>3</sup>)

( $\gamma = 1.2 \text{ kg/m}^3$  at 20°C, 1 atmospheric pressure)

g = acceleration of gravity = 9.8 (m/sec<sup>2</sup>)

Pn = differential pressure (mm H<sub>2</sub>O)

Ps = static pressure (mm H<sub>2</sub>O)

The measuring equipment using double chamber is method to be calculated from air flow goes through nozzle and differential pressure between pressure of inside of chamber (Ps) and atmospheric pressure by measuring differential pressure between air intake and exhaust of nozzle (Ph).

## Conversion Table

### Static pressure

1mm H<sub>2</sub>O = 0.0394inch H<sub>2</sub>O

1mm H<sub>2</sub>O = 9.8Pa (Pascal)

1inch H<sub>2</sub>O = 25.4mm H<sub>2</sub>O

1Pa = 0.102mm H<sub>2</sub>O

1inch H<sub>2</sub>O = 249Pa

### Air flow

1m<sup>3</sup>/min = 35.31ft<sup>3</sup>/min (CFM)

1CFM = 0.0283m<sup>3</sup>/min

1m<sup>3</sup>/min = 16.67 l /sec

1CFM = 0.472 l /sec

1 l /sec = 0.06m<sup>3</sup>/min

# Operating precautions

## Operating precautions

### Storage temperature

There is no performance problem when the system is used at between  $-30^{\circ}\text{C}$  and  $+70^{\circ}\text{C}$ . There is a possibility that same problem of lubricant and insulation inside motor might occur by condensing due to rapid surrounding temperature change. Therefore, please take care of non-condensing using desiccant or something during fan is in storage.

### Tightening Torque

This shows the recommended values for the tightening torque when installing the fans. If the tightening torque is higher than the recommended values, the fan can be deformed or damaged.

Use care when tightening. Also, be sure to always use a fan with a ribbed structure when using screws to pass through and secure the fan.

Recommended screw torques

AC fans :  $0.44\text{N}\cdot\text{m}$  (4.5kgf $\cdot\text{cm}$ ) or less (with M3 screws)

AC fans :  $0.78\text{N}\cdot\text{m}$  (8kgf $\cdot\text{cm}$ ) or less (with M4 screws)  
(160mm $\times$ 160mm,  $\phi$  172mm)

DC fans :  $0.44\text{N}\cdot\text{m}$  (4.5kgf $\cdot\text{cm}$ ) or less (with M3 screws)  
(Applies to fan motors of 52mm $\times$ 52mm or smaller)

DC fans :  $0.78\text{N}\cdot\text{m}$  (8kgf $\cdot\text{cm}$ ) or less (with M4 screws)  
(Applies to fan motors of 60mm $\times$ 60mm or bigger)

DC fans :  $0.98\text{N}\cdot\text{m}$  (10kgf $\cdot\text{cm}$ ) or less (with M4 screws)  
( $\phi$  200mm)

DC fans :  $0.75\text{N}\cdot\text{m}$  (7.35kgf $\cdot\text{cm}$ ) or less (with M4 screws)  
( $\phi$  220mm)

### Installation

There are no limitations on the installation direction of AC fans, DC fans, or blowers. AC/DC fans have symbols on the fan motor indicating the airflow direction and blade rotation direction. When installing, use these symbols to check the airflow direction.

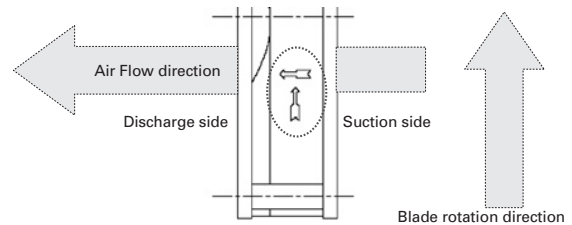

Symbols indicating the fan airflow direction and blade rotation direction

### Comparison of ribbed and ribless structures (in the case of plastic frame BLDC fan)

Regarding plastic frame, we have a option ribbed and ribless about mounting. Please use preferred type up to your application. Please use ribbed fan in case that you hook fan up clamping either side fan mounting hole target. (Ribless type of some models aren't available.)

\*Use a fan with a rib structure when using a screw for piercing.

\*The plastic frame models of DC fans are classified into ribbed models and ribless models based on the shape of the installation section of the frame.

- When securing screws to ribless plastic frame models, use a flange to secure on one side.

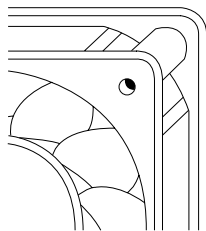

Ribbed

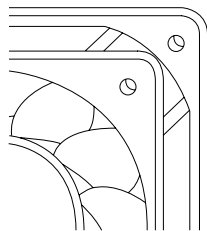

Ribless

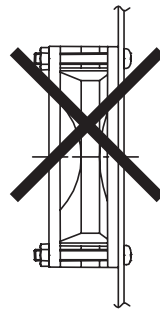

Securing with flanges on both sides

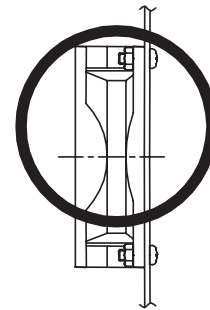

Securing with a flange on one side

### Handling precautions

Sanyo Denki's fans incorporate precise bearings. Therefore, please handle the motors carefully in order not to shock the bearings.

# Specifications for DC fan sensors

## Pulse sensor (Tach output type)

Pulse sensor outputs two pulse waves per revolution of fan, and it is good to detect fan speed. Pulse sensors can be incorporated in all kinds of BLDC fans.

\* Noise from inside the fan or from external devices may effect sensor output, please contact Sanyo Denki.

(Typical standard model: 109R1212H101).

### Output circuit

Open collector

### Specifications

$V_{CE} = +30V$  max

(For a 48V-rated fan:  $V_{CE} = +60V$  max)

$I_c = 10mA$  max [ $V_{OL} = V_{CE} (SAT) = 0.4V$  or less]

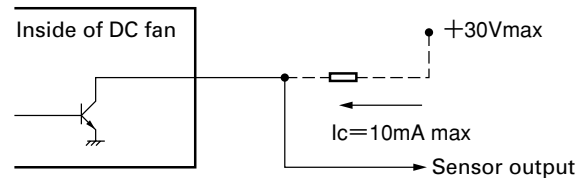

### Output waveform (Need pull-up resistor)

In case of steady running

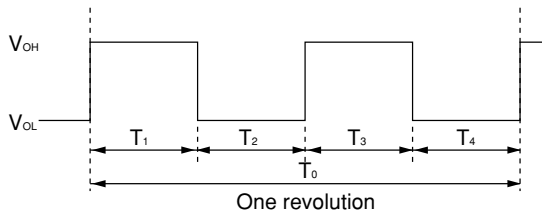

$$T_{1\text{ to }4} \approx (1/4) T_0$$

$$T_{1\text{ to }4} \approx (1/4) T_0 = 60/4N \text{ (sec)}$$

$$N = \text{Fan speed (min}^{-1}\text{)}$$

\* If you want detailed specifications that apply when the rotor is locked, please contact Sanyo Denki.



## Locked rotor sensor (rotation/lock detection type)

Locked rotor sensor outputs fan status signals. It is good to check whether the fan is running or locked

\* Noise from inside the fan or from external devices may effect sensor output, please contact Sanyo Denki.

\* Regarding details of the reverse logic and specifications of lock sensor output signals, please contact Sanyo Denki.

(typical standard model: 109R1212H1D01).

### Output circuit

Open collector

### Specifications

$V_{CE} = +27.6V$  max

For a 48V fan  $V_{CE} = +60V$  max.

$I_c = 5mA$  max [ $V_{OL} = V_{CE} (SAT) = 0.6V$  or less]

For a 48V fan:  $V_{CE} (SAT) = 0.4V$  or less

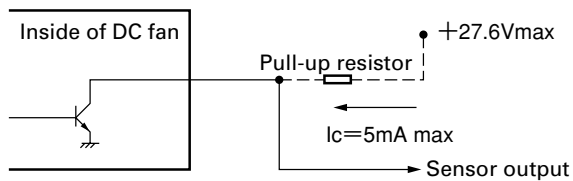

### Output waveform

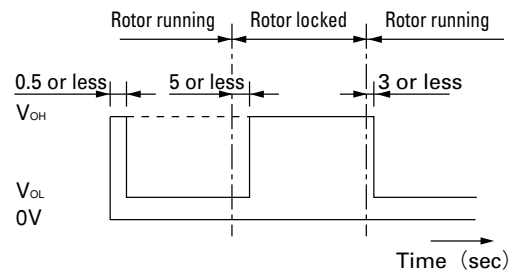

Note: The output is completely at  $V_{OL}$  with 0.5 seconds or less after power-up.

If you are using a thermal speed controlled fan or a two-speed fan, the output waveform is different from above.

### Output circuit:

Open collector

### Specifications:

$V_{CE} = 27.6V$  max

$I_c = 5mA$  max [ $V_{CE} (SAT) = 0.5V$  max.]

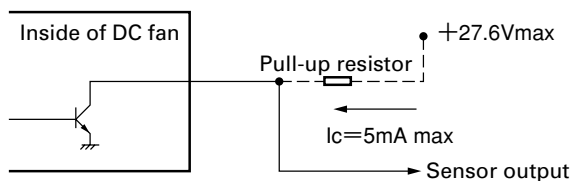

### Output waveform

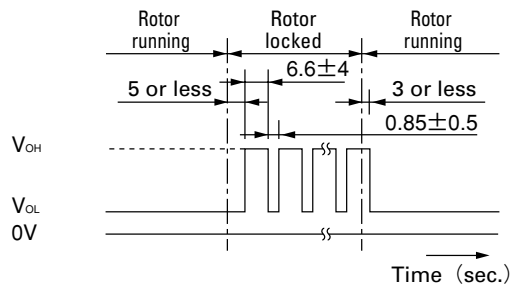

Note: The output is completely at  $V_{OL}$  with 0.5 seconds or less after power-up.

# Specifications for DC fan sensors

## Low-speed sensor (rotating speed detection type)

Low-speed sensor outputs a signal when fan speed goes down to trip point or less. It is good to detect cooling degradation of fan.

\*Noise from inside the fan or from external devices may effect sensor output, please contact Sanyo Denki.

(typical standard model: 109R1212H1H01).

### Output circuit

Open collector

### Specifications

$V_{CE} = 27.6V$  max.

$I_c = 10mA$  max. [ $V_{OL} = V_{CE} (SAT) = 0.5V$  or less]

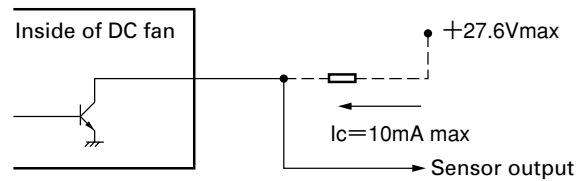

### Sensor scheme

Example 1:

In case steady running

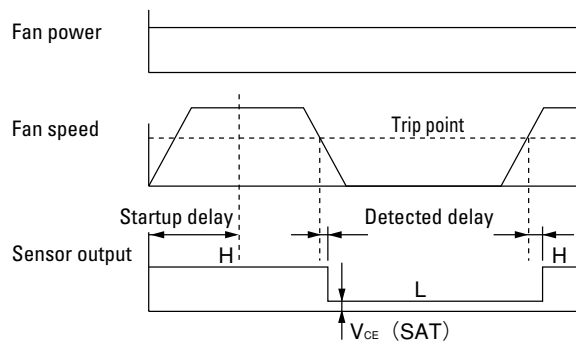

Example 2:

In case that the rotor is locked when the fan motor is turned on and released after the start-up delay time.

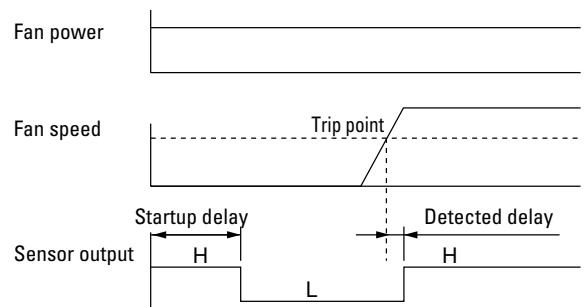

\* If you want detailed specification and reverse signal output, please contact Sanyo Denki.

# Specifications for AC fan sensor

## Specifications of sensor circuit

System	Speed detection, auto-restart.		
Power supply	4 to 14 VDC	( At 2mA, 5V ) ( At 5mA, 12V )	See Note 2.
Sensor circuit	I=100mAmax	PT=200mWmax (at 25°C)	
Output performance	Vc=27.6Vmax		
		Standard speed	Low speed
Trip point		Within 1,700min <sup>-1</sup> ±10%	Within 850min <sup>-1</sup> ±10%
Response speed	Startup delay	18sec	36sec
	Detection delay	1sec	2sec
Insulation resistance	10 MΩ or more at a 500 VDC megger		
Dielectric strength	50/60 Hz, 1,000 VAC, 1 minute; see Note 1		
Ambient conditions	Temperature: -10 to +60°C, humidity: 90%RH or less (at 40°C)		

Note 1: Between one end that all sensor leads consisting of brown, yellow and black are tied together and the G terminal or power terminal of the fan.

Note 2: Keep the power fluctuations within ±20% of applied power.

## Sensor scheme

Example 1: When the AC power for the fan and the DC power for the sensor are turned on at the same time

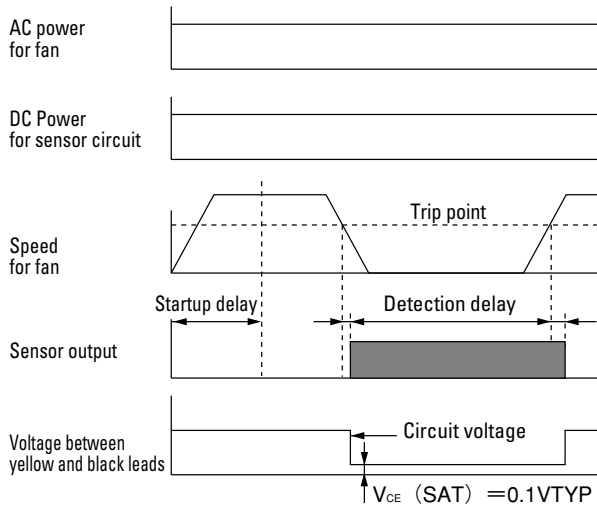

Example 2: When the AC power for the fan is turned on first, then the DC power for sensor is powered on

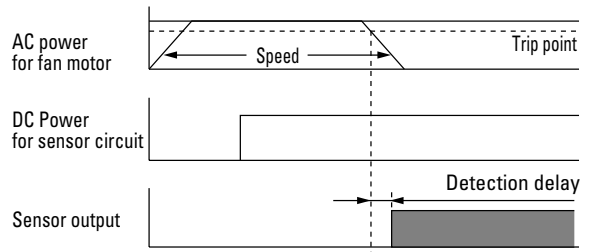

Example 3: When the DC power for sensor is first powered on, then the AC power for the fan is turned on

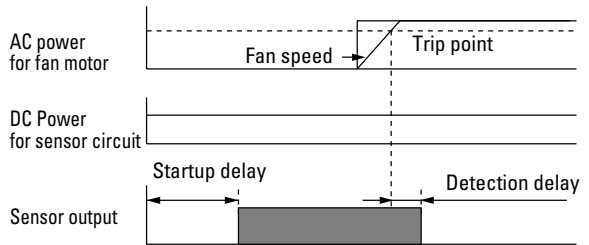

## Sensor Output Circuit

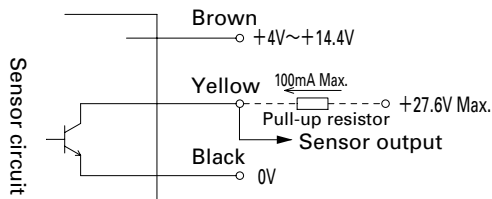

# Common Specifications

## Overheating protection function

### Protection Functions:

If the fan blades are restricted, an overcurrent occurs and leads to a rise in the fan coil temperature. This can result in reduced performance, damage, or a fire. To prevent this from occurring, Sony Denki's fans incorporate an overheating protection function. Refer to the catalog for the types of protection functions.

### 1) AC fan overheating protection functions

#### ● Impedance protection

This system is used for shading coil-type fans. When the blades are restricted, the current is reduced by the impedance of the coil itself to prevent a temperature rise in the coil. However, if the applied voltage exceeds the specification range, an overcurrent can occur and result in overheating, and so care needs to be taken.

#### ● Thermal protection

This system is used for condenser phase-type fans. A temperature sensor is incorporated in the coil so that if the temperature exceeds the specification temperature, the current is cut off to prevent overheating of the coil.

### 2) DC and blower overheating protection function

#### ● Current cutoff system

If the fan blades are restricted, the coil current is cut off at regular cycles to prevent overheating of the coil. When the hindrance is removed, the fan restarts automatically. (For the San Ace 200 E Type, however, the power needs to be turned off and on again to restart.)

## Eco Products



Sanyo Denki's ECO PRODUCTS are designed with the concept of lessening impact on the environment in the process from product development to waste. The product units and packaging materials are designed for reduced environmental impact. We have established our own assessment criteria on the environmental impacts applicable to all processes, ranging from design to manufacture. Those products that satisfy the criteria are accredited as ECO PRODUCTS.

---

# Safety standards

## ■ Description of safety standards

### 1. UL ratings (USA)



Underwriters Laboratories Inc. was established by the American Union of Fire Insurance Underwriters. The purpose of UL is to ensure safety of machines, equipment, and materials and protect human lives and property from fire and other accidents. To that end, UL has conducted numerous tests and extensive research and, as a result, set up UL ratings. Any seller of products in any of the majority of the states of the USA must produce their products according to the UL ratings, have them pass UL-specified safety inspections, and have them listed in UL's registration book. Therefore, to export and sell any product in the United States, one must in most cases apply for UL-listing.

Additionally, UL is accredited by The Standards Council of Canada (SCC) as both a Certification Organization (CO) and a Testing Organization (TO) and is officially recognized in all provinces and territories throughout Canada. Accordingly, our products can be tested by UL for compliance with Canadian safety standards. Certified products are entitled to display the C-UL Mark, which authorizes their use and sale in Canada. If products are deemed to be compliant with both U.S. and Canadian standards, then both the UL Mark and C-UL Mark can be displayed or a combination U.S. and Canadian mark (bottom left).

Our products are certified as satisfying all UL507 requirements.

### 2. CSA standards (Canada)



The Canadian Standards Association (CSA) was set up in response to the advice of the Canadian government. In Canada, the law prohibits the use and sale of any product other than those approved under CSA in terms of safety. CSA has set up CSA standards as inspection procedures and other requirements to ensure product safety.

Our products are certified as satisfying the CSA standard C22.2 No. 113.

### 3. EN standards (EU members)



In the EU territory, the harmonization of industrial standards and safety standards of different countries is under way. The unified standards are called Harmonized Standards. Each of these standards is marked EN above the standard number. EN standards offer the grounds in design and manufacture when one exports a product to the EU territory. In order for a product to receive a safety marking, the product must be found to conform to TÜV, VDE, or other relevant standard.

Our products are certified as satisfying all TÜV Rheinland EN60950 requirements.

4. Electrical Appliance and Material Safety Law

As of April 1, 2001, the Electrical Appliance and Material Control Law has been revised and reenacted as the Electrical Appliance and Material Safety Law.

AC fans are classified as 'Blowers' under 'Electric motor-operated appliances'. They are categorized as electrical products other than specific electrical appliances (with the exception of some models) and are required to be labeled to indicate PSE certification.

■ CE marking

To distribute their equipment in the EU territory, manufacturers are obligated to give a CE marking as proof that the equipment conforms to related EU directives. Manufacturers use EN standards as criteria of judgment as to whether the equipment satisfies the requirements of specific directives or, in the absence of applicable EN standards, they use IEC standards. Manufacturers then prepare a self-declaration to indicate that the equipment conforms to related directives and apply a CE marking. (Depending on the degree of risk of the equipment, some kinds of equipment are required to receive type tests conducted by certified authorities and, after a type test certificate is obtained, manufacturers make a self-declaration.)

Scope of application and compulsory timing of major EC directives

**Machine directives** (89/392/EEC, 91/368/EEC, and 93/44/EEC)  
 These directives apply to equipment that has a moving part that may injure humans. The directives generally apply to a wide range of machine tools and other industrial machines (became compulsory on January 1, 1995).

**EMC directives** (89/326/EEC and 92/31/EEC)  
 They apply to equipment which may be affected by electromagnetic interference (EMI) or has electromagnetic susceptibility (EMS) (became compulsory on January 1, 1996).

**Low-voltage directive** (73/23/EEC)  
 This directive applies to equipment that is used in an AC range between 50 and 1,000V and in a DC range between 75 and 1,500V (became compulsory on January 1, 1997).



CE marking

**JIS: Japanese Industrial Standards**

Japan's national standards related to mining and manufacturing industries

**IEC : International Electrotechnical Commission**

This is an international commission on electrical standardization. This commission promotes the unification and cooperation of international standards related to electric and electronics engineering and issues IEC standards in order eventually to allow different countries to conform to the international standards.

**DIN : Deutsches Institut für Normung e.V.**

This is a German standards institute. The institute uses a wide-range set of standards covering many industrial sectors. The set of standards includes basic standards.

**VDE : Verband Deutscher Elektrotechniker e.V.**

It is a German association of electric engineers. VDE establishes safety standards related to electrical engineering and issues them as DIN-VDE standards.

# Safety standard list

## ■ AC Fan

✓...UL·CSA·and TÜV acquired

Flame size	Thickness	Model.No	Rated voltage	UL	CSA	TÜV	CE
60×60mm	28mm	109-180	100	✓		✓	✓
		109-183	115	✓		✓	✓
	38mm	109-130	100	✓		✓	✓
		109-133	115	✓		✓	✓
80×80mm	20mm	109-210	100	✓	✓	✓	✓
		109-213	115	✓	✓	✓	✓
	25mm	109S050	100	✓	✓	✓	✓
		109S053	115	✓	✓	✓	✓
		109S051	200	✓	✓	✓	✓
		109S054	230	✓	✓	✓	✓
		109S030	100	✓	✓	✓	✓
		109S033	115	✓	✓	✓	✓
		109S031	200	✓	✓	✓	✓
		109S034	230	✓	✓	✓	✓
	38mm	109-150	100	✓	✓	✓	✓
		109-153	115	✓	✓	✓	✓
		109-151	200	✓	✓	✓	✓
	42mm	109-154	230	✓	✓	✓	✓
		109-040UL	100	✓	✓	✓	✓
		109-043UL	115	✓	✓	✓	✓
		109-041UL	200	✓	✓	✓	✓
		109-044UL	230	✓	✓	✓	✓
		109-047UL	100	✓	✓	✓	✓
	92×92mm	25mm	109-033UL	115	✓	✓	✓
109S091			100	✓	✓	✓	✓
109S093			115	✓	✓	✓	✓
109S092			200	✓	✓	✓	✓
109S094			230	✓	✓	✓	✓
109S095			100	✓	✓	✓	✓
109S096			100	✓	✓	✓	✓
109S193			115	✓	✓	✓	✓
120×120mm	25mm	109S192	200	✓	✓	✓	✓
		109S194	230	✓	✓	✓	✓
		109S085	100	✓	✓	✓	✓
		109S084	115	✓	✓	✓	✓
		109S088	200	✓	✓	✓	✓
		109S087	230	✓	✓	✓	✓
		109S081	100	✓	✓	✓	✓
		109S083	115	✓	✓	✓	✓
	38mm	109S082	200	✓	✓	✓	✓
		109S089	230	✓	✓	✓	✓
		109S086	100	✓	✓	✓	✓
		109S075UL	100	✓	✓	✓	✓
		109S074UL	115	✓	✓	✓	✓
		109S078UL	200	✓	✓	✓	✓
		109S072UL	230	✓	✓	✓	✓
		109S029UL	100	✓	✓	✓	✓
160×160mm	51mm	109S013	100	✓	✓	✓	✓
		109S006	100				
		109S006UL	100/115	✓	✓	✓	✓
		109S010	200				
	38mm	109S010UL	200/240	✓	✓	✓	✓
		109S005	100				

Flame size	Thickness	Model.No	Rated voltage	UL	CSA	TÜV	CE
120×120mm	38mm	109S005UL	100	✓	✓	✓	✓
		109S024	120				
		109S024UL	115	✓	✓	✓	✓
		109S008	200				
		109S008UL	200	✓	✓	✓	✓
		109S025	230				
		109S025UL	230	✓	✓	✓	✓
160×160mm	51mm	109-601	100	✓	✓	✓	✓
		109-604	115	✓	✓	✓	✓
		109-602	200	✓	✓	✓	✓
		109-603	230	✓	✓	✓	✓
φ172mm×150mm Sidecut type	51mm	109S301	100	✓	✓	✓	✓
		109S304	115	✓	✓	✓	✓
		109S302	200	✓	✓	✓	✓
		109S303	230	✓	✓	✓	✓
φ172mm Round type	51mm	109-311	100	✓	✓	✓	✓
		109-314	115	✓	✓	✓	✓
		109-312	200	✓	✓	✓	✓
		109-313	230	✓	✓	✓	✓

## ■ AC Fan with Sensor

✓...UL·CSA·and TÜV acquired

Flame size	Thickness	Model.No	Rated voltage	UL	CSA	TÜV	CE
92×92mm	25mm	109S491	100	✓		✓	✓
		109S493	115	✓		✓	✓
		109S492	200	✓		✓	✓
		109S494	230	✓		✓	✓
		109S495	100	✓		✓	✓
		109S496	100	✓		✓	✓
120×120mm	25mm	109S485	100	✓		✓	✓
		109S484	115	✓		✓	✓
		109S488	200	✓		✓	✓
		109S487	230	✓		✓	✓
	38mm	109S486	100	✓		✓	✓
		109S475UL	100	✓	✓	✓	✓
		109S474UL	115	✓	✓	✓	✓
		109S478UL	200	✓	✓	✓	✓
		109S472UL	230	✓	✓	✓	✓
		109S405UL	100	✓		✓	✓
160×160mm	51mm	109S424UL	115	✓		✓	✓
		109S408UL	200	✓		✓	✓
		109S425UL	230	✓		✓	✓
		109S429UL	100	✓		✓	✓
φ172mm	51mm	109S406UL	100	✓		✓	✓
		109-641	100	✓		✓	✓
		109-644	115	✓		✓	✓
		109-642	200	✓		✓	✓
		109-643	230	✓		✓	✓

# Safety standard list

## ■ DC Fan

All of the San Ace DC cooling fans acquires UL, CSA and TÜV standards except for the following products,

\*...UL·CSA·and TÜV Pending

Flame size	Thickness	Model.No	Rated voltage	UL	CSA	TÜV
40×40mm	28mm	9L0412J302	12	*	*	*
		9L0412H302	12	*	*	*
		9L0412M302	12	*	*	*
40×40mm	20mm	9WF0424H602	24	*	*	*
60×60mm	25mm	9WF0624H402	24	*	*	*
120×120mm	38mm	9WF1224H102	24	*	*	*
60×60mm	25mm	9WP0612H402	12	*	*	*
		9WP0612H4021	12	*	*	*
		9WP0624H402	24	*	*	*
		9WP0624H4021	24	*	*	*
120×120mm	38mm	9WP1212H102	12	*	*	*
		9WP1212H1021	12	*	*	*
		9WP1224H102	24	*	*	*
		9WP1224H1021	24	*	*	*
		9WP1248H102	48	*	*	*
150×150mm	50mm	9GV1512H502(5021)	12	*	*	*
		9GV1512M502(5021)	12	*	*	*
		9TR48HA0	48	*	*	*
φ220mm	71mm					

※The contents of this catalog is as of March 2006.

Please ask us about new products that we released after March 2006 if you want.

Standard name	Certification number
UL	E46810
CSA	172248

※TÜV certification numbers differ by model.

## ■ CPU Cooler

✓...UL·CSA·and TÜV acquired

Socket	Rated current	Model.No	UL	CSA	TÜV
Socket370 (FC-PGA)	12	109X6512A2016			
Socket370 (FC-PGA2)	12	109X7612H1176	✓		
Socket370 (FC-PGA2)	12	109X7412S4016	✓		
Socket423	12	109X9612S5016	✓		
Socket423	12	9H9912G5016			
Socket478	12	109X9812H0016	✓		
Socket478	12	109X9812T0H016	✓		
Socket478	12	109X9912S0016	✓		
Socket478	12	109X9912T0S016	✓		
Socket478	12	109X9912T0D516	✓		
Socket478	12	109X9412S1016			
Socket478	12	109X9412G4016	✓		
Socket478	12	9H9912G5516			
775-land LGA Package	12	109X9212PT0H016	✓		
775-land LGA Package	12	109X9112PT0H016	✓		
775-land LGA Package	12	9G0912P2E012	✓		
775-land LGA Package	12	9G0912PT2E012	✓		

## ■ Liquid Cooling Solution System

✓...UL·CSA·and TÜV acquired

Socket	Rated current	Model.No	UL	CSA	TÜV
Socket478	12	109-LC1-001	✓		

## ■ Plug Code

✓...UL·CSA·and TÜV acquired

Model.No	UL	CSA	TÜV	CE	Applicable model
489-008-L10					80×80×42mm
489-008-L21					80×80×42mm
489-008-L35					80×80×42mm
489-016-L10					120×120×25mm 92×92×25mm 80×80×25mm 80×80×38mm
489-016-L21					120×120×25mm 92×92×25mm 80×80×25mm 80×80×38mm
489-006-L10					120×120×38mm
489-006-L21					120×120×38mm
489-007-L10	✓	✓			120×120×38mm
489-007-L21	✓	✓			120×120×38mm
489-047-L10	✓	✓			120×120×25mm 92×92×25mm 80×80×25mm 80×80×38mm
489-047-L21	✓	✓			120×120×25mm 92×92×25mm 80×80×25mm 80×80×38mm
489-084-L10	✓	✓			φ172mm×51mm 160×160×51mm L-Shaped
489-084-L21	✓	✓			φ172mm×51mm 160×160×51mm L-Shaped
489-086-L10	✓	✓			φ172mm×51mm 160×160×51mm Straight
489-086-L21	✓	✓			φ172mm×51mm 160×160×51mm Straight



# COOLING SYSTEMS

## San Ace

## Product Guide

### DC Fans

Long life, low noise axial cooling fans optimized for mostly server or communication devices.

### Thermal Speed Controlled Fans

Two types: external and internal thermistor.

### Splash Proof Fans

Axial cooling fans optimized for outdoor devices or devices that are used in high-humidity environment.

### Oil Fans

The axial fan that can use under tough condition like oil mist.

### Long Life Fans

The expected life is 100,000 hours (□120mm : 200,000 hours), optimized for maintainance-free devices required.

### Blowers

High static pressure centrifugal cooling fans optimized for draft-resistant, high heat release devices.

### Centrifugal Fans

The high air flow centrifugal fan that is ideal for telecommunication equipments, large server and network storage system.

### CPU Coolers · Liquid Cooling Solution Systems

CPU cooler with low noise, low vibration and high heat dissipation that consists of fan motor and heatsink can effectively cool PC down.

### AC Fans

Long life, low noise axial cooling fans optimized for devices with high system impedance and high heat generation.

### Option

Option guide optimized for various fans.

DC Fans

Thermal Speed  
Controlled Fans

Splash Proof Fans

Oil Proof Fans

Long Life Fans

Blowers

Centrifugal Fans

CPU Coolers  
Liquid Cooling  
Solution System



AC Fans

Option

## Safety Precautions

- In order to ensure that this product is used safely, be sure that you read and understand the following precautions fully and use the product only as directed.
- Be sure to read these Safety Precautions carefully before installing, connecting, operating, maintaining, or inspecting this product. Follow all the precautions and directions given here.
- This product has been designed and manufactured for use as a device to be used in general industrial machinery, and may not be used as a standalone product.
- The product of our company (hereafter called the product) falls into the category of the products specified in the Attached List 1, Item 16 (Class 85, Item 01) of the Export Trade Control Ordinance. To export the product as an individual part or to export a product into which the product is assembled, the "Information Requirements" and "Objective Requirements" that the Ministry of Economy, Trade and Industry established based on the "Catchall Controls" must be studied for applicability. Based on information on applicability and specified requirements, appropriate export formalities must be performed.

In order to prevent any possible bodily injury or damage to property or equipment, the following precautions for ensuring safety are displayed according to the following two ranks of importance:

 <b>Danger</b>	Handling or using the product improperly and in disregard of the instructions with this mark might result in serious bodily injury or death.
 <b>Warning</b>	Handling or using the product improperly and in disregard of the instructions with this mark might result in bodily injury or physical damage.

※ Note: Items marked 'Warning' might also result in serious bodily injury or death in some circumstances. Always follow the instructions for items marked 'Danger'.

Descriptions of the precautions to be taken to ensure safety are given below.

### **Danger**

- If the product is used in medical appliances or other types of equipment that affect people's lives, sufficient safety-related evaluations and preparations must be made in advance, and the product or the type of equipment into which the product is assembled must be used on the user's own responsibility.
- If the product is used in types of equipment that have a strong social and public impact, sufficient prior evaluations and safety-related evaluations and preparations must be made, and the product or the type of equipment into which the product is assembled must be used on the user's own responsibility.
- If the product is used in an environment where there are vibrations, for example, in a car or aboard a ship, sufficient prior evaluations and safety-related evaluations and preparations must be made, and the product or the piece of equipment into which the product is assembled must be used on the user's own responsibility.
- Connect all wires properly and securely. Failure to do so might result in burns, fire, or exposure to electrical shock.
- If there are any grounding taps or wires, attach all grounds securely. Failure to do so might result in exposure to electrical shock.
- Never use in explosive atmosphere, as doing so might result in fires, burns, or bodily injury.
- Never operate with any live wires exposed, as doing so might result in electrical shock.
- Never allow any persons or objects to approach or come into contact with the rotor while in operation, as doing so might result in damage or personal injury.
- Turn off the power and stop using the product immediately if you notice any sparks, smoke, odd odors, sounds, or anything unusual during operation. Failure to do so might result in fire, burns, or electrical shock.
- Never allow the product to fall, topple over, or otherwise be subjected to excessive shocks when moving it, as doing so might result in product breakdown or substandard operation.
- The product should be handled only by personnel with sufficient training and knowledge and under the responsibility of the end user.
- Never attempt to disassemble, repair, or alter this product in any way, as doing so might result in fire, burns, or electrical shock.

---

## Warning

- If the fan stops during operation, give proper consideration to the device for its protection.
- Installation, placement, connections, wiring, or relocation of the product should be performed by knowledgeable or correctly licensed personnel. Never perform such work while the product is live as this might lead to injury, electrical shock, burns, or fire.
- When fixing this product into place, be sure to take into consideration the product's weight, the vibrations generated during operation, and all other relevant factors. Failure to do so might cause the product or parts of it to fall out of position, resulting in bodily injury or malfunction of the product.
- Be sure to check the direction of installation (i.e., the fan), as failing to do so might result in bodily injury or mechanical breakdown.
- In order to ensure that the product operates properly, allow spaces for ventilation and take whatever steps necessary to prevent the entry of foreign objects. Failure to do so might result in bodily injury or mechanical breakdown.
- The product might become damaged if foreign objects or external forces are allowed to interfere with normal fan operation.
- Install a finger guard or other cover if there is any danger of fingers, hands or objects coming into contact with the rotor or blades. Failure to do so might result in bodily injury or mechanical breakdown.
- Pulling or pinching the lead wires could result in damage to the wire, and you should avoid placing excessive stresses on these wires. The device should also be installed so that the lead wires are not allowed to come into contact with the rotor or blades. Failure to do so might result in damage or exposure to electrical shock.
- Never insert or remove any plug cords or connectors while the power is turned on. When inserting or removing plugs or connections, always be sure to first check that the power has been turned off and hold the housing of the plug or connector when doing so. Failure to do so might result in damage or exposure to electrical shock.
- Never attempt to disassemble or alter this product in any way. Doing so might invalidate any warranties concerning the functions or performance of the product, and might also result in fire, burns, bodily injury, or electrical shock.
- Take proper precautions against static electricity when making electrical connections. Failure to do so might cause the breakdown of the fan or device.
- The fan may fail to operate properly if there is insufficient power capacity, because the starting current's amperage is several times larger than the rated amperage and the current will flow at the very instant the voltage is supplied to the fan. Be sure to inquire about startup current levels for individual models.
- Never remove the product identification plate or install the product so that the identification cannot be seen after installation. This could result in the product being improperly used, and subsequently result in fires.
- The product must not be used or stored in a flammable or corrosive gas atmosphere, in a place where water or oil splashes (not applicable to Splash Proof or Oil Proof Fans), in a place where there is much dust or humidity, in a place where condensation occurs, in a place where the product is exposed to radioactive rays or is in direct sunlight, in a place where a salty sea breeze blows or seawater splashes, or in an environment where the product may be contaminated by such corrosive materials as sulfurous water, sulfurous volcanic ash, organic solvents, acidic chemicals, alkali chemicals, etc., such hazardous substances as nuclear fuel materials, etc. If it is used or stored in such places or environments, there is the possibility that a fire may occur, the product may malfunction or its performance may deteriorate.
- Never use the product at voltages, temperatures, or any other settings which exceed those given in the product specifications. This might result in breakdown, fire, bodily injury, or electrical shock.
- Avoid using or storing the product in locations where it could be constantly exposed to vibrations, strong shocks, magnetic or electromagnetic noise. This might result in product breakdown or substandard operation.
- Maintenance and inspections should always be performed by personnel with sufficient training and knowledge. Failure to do so might result in fire, burns, bodily injury, or electrical shock.
- Never perform any maintenance or inspections while the product is in operation. Also note that the blades continue to rotate for some time immediately after operation ceases. You should always be sure to check to see that all rotating parts have come to a stop before beginning work.
- Never allow yourself to come into contact with the ends of wires or plugs when measuring the insulation resistance or maximum voltage. This might result in electrical shock.
- Never use gasoline, paint thinner, benzene, or any other organic solvents to clean the product as this could result in the deformation or substandard operation.
- When disposing the product, always dispose of it as industrial waste. For instructions on proper disposal methods, please contact local government authorities.

## Part Numbering System

### DC Fans

<b>9G</b>	<b>12</b>	<b>12</b>	<b>G</b>	<b>1</b>	<b>02</b>	<b>1</b>
<b>Series name / frame material</b> 109P / Plastics 109R / Plastics 9GV / Plastics Aluminum 9G / Plastics 9A / Plastics 9CR / Plastics 9CRA / Plastics 9SG / Aluminum 109E / Aluminum 9EC / Aluminum	<b>Frame dimensions</b> 04 : 40×40mm 05 : 52×52mm 06 : 60×60mm 08 : 80×80mm 09 : 92×92mm 12 : 120×120mm 13 : 127×127mm 15 : 150×150mm 17 : φ172 47 : φ172×147 (side cut) 57 : φ172×150 (side cut) 20 : φ200	<b>Voltage</b> 05 : 5V 12 : 12V 24 : 24V 48 : 48V etc	<b>Speed code</b> A,B,C,D,E,F,G,H, J,K,L,M,S,W etc Two speed : MH, LM,HD,HE etc	<b>Frame thickness</b> 0 : 70mm thick 1 : 38mm thick 2 : 32mm thick 3 : 28mm thick 4 : 25mm thick 5 : 50mm thick 51mm thick 56mm thick 6 : 20mm thick 7 : 15mm thick 9 : 10mm thick	<b>Sensor specifications</b> 01 : With a pulse sensor 02 : Without a sensor D01 : With a lock sensor	<b>Frame type</b> Nil : Ribbed Plastics frame Nil : Ribless aluminum frame 1 : Ribless Plastics frame 3 : Plastics frame 40×40×28mm for 1U applications

### Splash Proof Fans

<b>109W</b>	<b>12</b>	<b>12</b>	<b>H</b>	<b>1</b>	<b>02</b>	<b>1</b>
<b>Series name / frame material</b> 109W / Aluminum 9WS / Plastics 9WG / Aluminum 9WB / Aluminum 9WP / Plastics	<b>Frame dimensions</b> 06 : 60×60mm 08 : 80×80mm 09 : 92×92mm 12 : 120×120mm 14 : 140×140mm	<b>Voltage</b> 12 : 12V 24 : 24V 48 : 48V etc	<b>Speed code</b> A,D,E,F,G,H,J,L, M,S etc	<b>Frame thickness</b> 1 : 38mm thick 4 : 25mm thick 5 : 51mm thick	<b>Sensor specifications</b> 01 : With a pulse sensor 02 : Without a sensor D01 : With a lock sensor	<b>Frame form</b> Nil : Ribbed Plastics frame Nil : Ribless aluminum frame 1 : Ribless Plastics frame

### Oil Proof Fans

<b>9WF</b>	<b>12</b>	<b>24</b>	<b>H</b>	<b>1</b>	<b>02</b>	
<b>Series name / frame material</b> 9WF / Plastics	<b>Frame dimensions</b> 04 : 40×40mm 06 : 60×60mm 12 : 120×120mm	<b>Voltage</b> 24 : 24V	<b>Speed code</b> H	<b>Frame thickness</b> 1 : 38mm thick 4 : 25mm thick 6 : 20mm thick	<b>Sensor specifications</b> 01 : With a pulse sensor 02 : Without a sensor D01 : With a lock sensor	<b>Frame form</b> Nil : Ribbed Plastics frame

### Long Life Fans

<b>109L</b>	<b>12</b>	<b>12</b>	<b>H</b>	<b>1</b>	<b>02</b>	
<b>Series name / frame material</b> 109L / Aluminum 9LB / Aluminum 9GL / Aluminum 9L / Aluminum	<b>Frame dimensions</b> 04 : 40×40mm 06 : 60×60mm 08 : 80×80mm 09 : 92×92mm 12 : 120×120mm 14 : 140×140mm 17 : φ172 57 : φ172×150(side cut)	<b>Voltage</b> 12 : 12V 24 : 24V 48 : 48V etc	<b>Speed code</b> E,F,G,H,J,L,M,S etc	<b>Frame thickness</b> 1 : 38mm thick 3 : 28mm thick 4 : 25mm thick 5 : 51mm thick	<b>Sensor specifications</b> 01 : With a pulse sensor 02 : Without a sensor D01 : With a lock sensor	<b>Frame form</b> Nil : Ribless

## Thermally Speed Controlled Fans

<b>109R</b>	<b>12</b>	<b>12</b>	<b>T</b>	<b>1</b>	<b>H</b>	<b>11</b>	<b>2</b>
<b>Series name / frame material</b> 109P / Plastics 109R / Plastics	<b>Frame dimensions</b> 05 : 52×52mm 06 : 60×60mm 08 : 80×80mm 09 : 92×92mm 12 : 120×120mm	<b>Voltage</b> 12 : 12V etc	<b>Speed code</b> T : Thermal speed control	<b>Frame thickness</b> 1 : 38mm thick 4 : 25mm thick 6 : 20mm thick 7 : 15mm thick	<b>Speed type</b> H etc	<b>Sensor specifications</b> 10 : With a lock sensor 11 : With a pulse sensor 12 : Without a sensor	<b>External view code</b> Nil : Ribbed frame product with an external thermistor 1 : Ribless frame product with an external thermistor 2 : Ribbed frame product with a built-in thermistor 3 : Ribless frame product with a built-in thermistor

## Blowers

<b>109B</b>	<b>F</b>	<b>12</b>	<b>H</b>	<b>A</b>	<b>2</b>
<b>Series name / frame material</b> 109B / Plastics 9B / Plastics	<b>Frame dimensions</b> C : 52×52mm F : 120×120mm D : 76×76mm J : 127×127mm E : 94×94mm N : 150×150mm M : 97×97mm G : 160×160mm AM : 97×97mm	<b>Voltage</b> 12 : 12V 24 : 24V etc	<b>Speed code</b> F,G,H,M,S etc	<b>Sensor specifications</b> A : Without a sensor C : With a pulse sensor D : With a lock sensor	<b>Frame thickness</b> 1 : 40mm thick 2 : 30mm thick, 32mm thick, 33mm thick 4 : 25mm thick 6 : 20mm thick 7 : 15mm thick

## Centrifugal Fans

<b>9TR</b>	<b>48</b>	<b>H</b>	<b>A</b>	<b>O</b>
<b>Series name / Attachment base</b> 9TR / Aluminum	<b>Voltage</b> 48 : 48V	<b>Speed code</b> H	<b>Sensor specifications</b> A : Without a sensor C : With a pulse sensor	<b>Frame thickness</b> 0 : 71mm thick

## CPU Coolers

<b>109X</b>	<b>99</b>	<b>12</b>	<b>S</b>	<b>0</b>	<b>01</b>	<b>6</b>
<b>Series name / frame material</b> 109X / Plastics 9H / Plastics	<b>Product dimensions</b> For model numbers starting with 109X 65 : 64×50.8mm 76 : 68×67.3mm 74 : 79×67.3mm 94 : 83.3×68.5mm 87.2×68.5mm For model numbers starting with 9H 99 : 83.3×70mm 88.9×70mm	<b>Voltage</b> 12 : 12V etc	<b>Speed code</b> A,D,G,H,S etc	<b>Thickness code</b> 0,1,2,4,5 etc	<b>Sensor specifications</b> 01 : With a pulse sensor 02 : Without a sensor	<b>Heat sink specification</b> 6 : With a heat sink

## CPU Coolers with Speed Control

<b>109X</b>	<b>99</b>	<b>12</b>	<b>T</b>	<b>0</b>	<b>S</b>	<b>01</b>	<b>6</b>
<b>Series name / frame material</b> 109X / Plastics 9G / Plastics	<b>Product dimensions</b> For model numbers starting with 109X 92 : φ90mm 98 : 91.6×71.3mm 99 : 95×67.5mm For model numbers starting with 9G 09 : 92×92mm	<b>Voltage</b> 12 : 12V etc	<b>Speed code</b> T : Thermal speed control PT : PWM control with thermal speed control P : PWM control	<b>Thickness code</b> 0 etc	<b>Speed code</b> A,D,G,H,S etc	<b>Sensor specifications</b> 01 : With pulse sensor 02 : Without sensor	<b>External view code</b> 2 : Duct+Heatsink [For BTX Thermalmodule] 6 : With a heat sink

## Liquid Cooling Solution Systems

<b>109</b>	<b>-</b>	<b>LC1</b>	<b>-</b>	<b>001</b>
<b>Represents a liquid cooling solution system.</b> LC1				

\*For inquiries concerning frame sizes, voltage, speed types, sensors (including lock sensors and low-speed sensors), speed control systems (including the two-speed system, the thermal speed control system, the PWM control function and the microprocessor control system) that are not covered in the catalog or on connectors, please contact us.

## Cooling Fan Units



Example of application  
Cooling Fan Unit



Example of application  
Cooling Fan Unit for 1U Server

- We build cooling systems that are most suitable for the client's application. The unit includes a range of cooling fans that are optimally adjusted according to the environment and a custom-made fan unit.
- In addition, we design and develop fan tray that are optimally suited to the client's requirements.

## Lineup

Our rich lineup of cooling fans includes tray that are designed for telecommunication equipment, such as servers, routers and storage devices, as well as some other equipments.



**DC Cooling Fan DC San Ace**  
40mm~200mm square.  
10mm~70mm thickness.



**DC Cooling Fan DC San Ace**  
172mm square (140mm wide)  
25mm thickness.



**Splash-proof Fan San Ace W/ WS**  
80mm~140mm square.  
25mm~51mm thickness.



**Blower San Ace B**  
52mm~160mm square.  
25mm~40mm thickness.



**Long Life Fan San Ace L**  
60mm~172mm square.  
25mm~51mm thickness.

- In addition to the product lineup above, we can offer a programmable control fans and thermal speed control fans.

## Electrolytic Corrosion Proof Fans

- This cooling fan prevents electrolytic corrosion of bearings even under conditions where electromagnetic noise is generated.
- Electrolytic corrosion of ball bearings is prevented by using ceramic balls in ball bearings.  
The ceramic material is an insulating material.

### ■ Structure

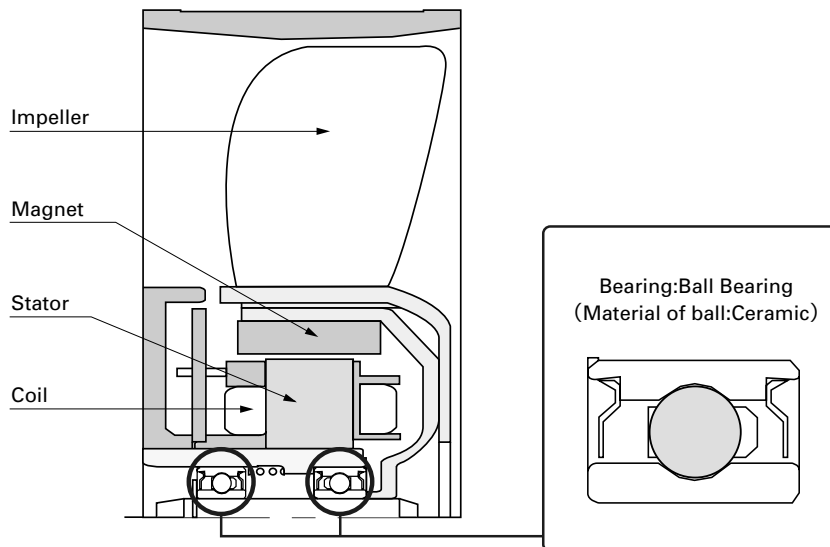

### Caution

Electrolytic Corrosion Proof Fan has been designed to prevent the electrolytic corrosion of ball bearings in the fan, but this does not guarantee that the fan will operate normally under conditions where there is strong electromagnetic noise.

Please be sure to fully evaluate the value of fan malfunction due to noise in advance.



## Lineup

- Electrolytic corrosion proof specification can be applied to our entire San Ace.



### DC Cooling Fan

40mm to 140mm sq. /  $\phi$  172mm to  $\phi$  200mm  
10mm to 70mm thickness.



### AC Cooling Fan

60mm to 160mm sq. /  $\phi$  172mm  
20mm to 42mm thickness.



### Long Life Fan

40mm to 140mm sq. /  $\phi$  172mm  
25mm to 51mm thickness.



### Splash-proof Fan

60mm to 140mm sq.  
25mm to 51mm thickness.

## Fans with the PWM control function



This picture shows 120×120×38mm fan.

## Pulse Width Modulation Speed Control

### Features

PWM speed control is the feature that fan speed is externally controlled by a constant input frequency with a varying duty cycle. It is good for efficient cooling, power saving and noise reduction for system because fan speed is appropriately adjusted when needed.

### ■ PWM Speed Control Scheme

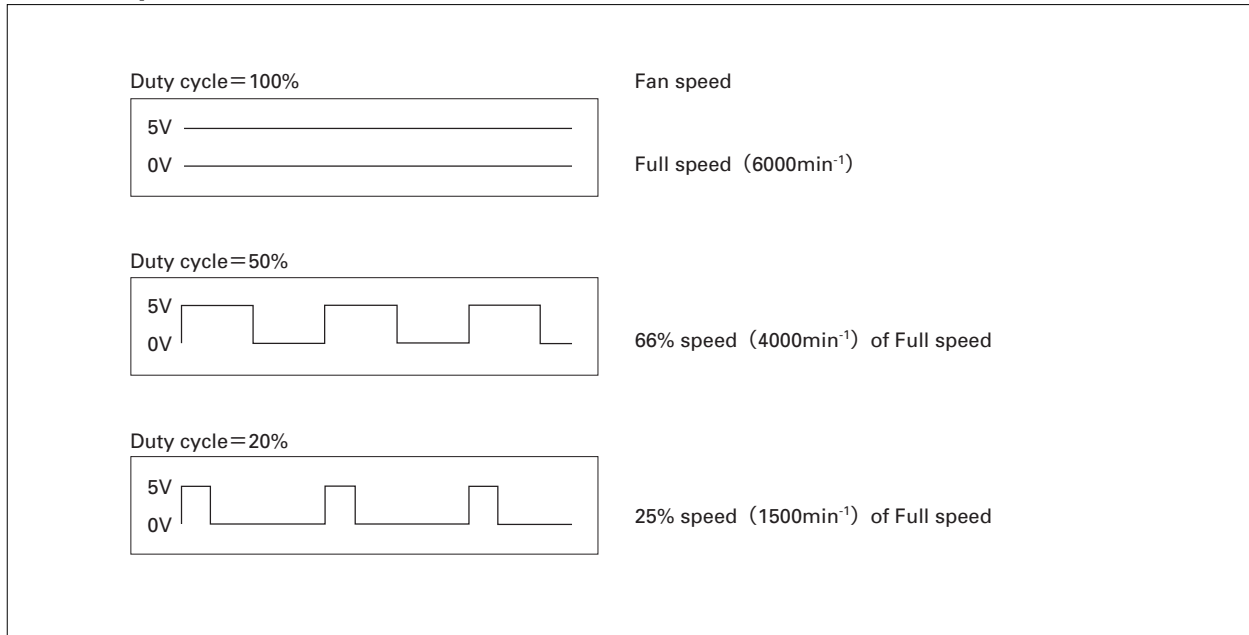

## Lineup

### Fans with the PWM control function

#### Available size and example of characteristics

Size (mm)	Model No.	Voltage (V)	Rated Speed (min <sup>-1</sup> )	Frequency (KHz)	Duty Cycle (%)	Current (A)	Airflow (m <sup>3</sup> /min (CFM))		Static Pressure (Pa) (inchH <sub>2</sub> O)		Noise (dB[A])
40×40×28	9GV0412P3J**	12	14,700	25	100	0.60	0.68	24	331	1.33	55
			0~4,410②		0	—	—	—	—	—	—
60×60×38	9G0612P1G**	12	11,800	25	100	1.54	1.84	65	436	1.75	58
			0~3,540②		0	—	—	—	—	—	—
80×80×38	9G0812P1G**	12	6,300	25	100	1.10	2.55	90	212	0.85	51
			0~1,890②		0	—	—	—	—	—	—
92×92×32	9G0912P2G**	12	5,000	25	100	0.88	2.83	100	147	0.59	50
			0~1,500②		0	—	—	—	—	—	—
120×120×38	9SG1212P1G**	12	6,000	16	100	4.00	7.35	260	340	1.37	64
			0~1,800②		0	—	—	—	—	—	—
172×150×51	109E5712P5K**	12	4,100	25	100	2.90	8.49	300	244	0.98	60
			0~1,230②		0	—	—	—	—	—	—

The numerals on \* marking depend on each fan spec. Please ask us if you need those details.  
Please ask us about speed at 0% duty cycle.  
It should be 0 to 30% speed of rated speed as a rough target.  
Tach outout is embedded for all the standard part numbers.

### Fan example with the PWM control function : 9G0812P1G04

#### PWM Duty - Speed Characteristics Example

[Example]

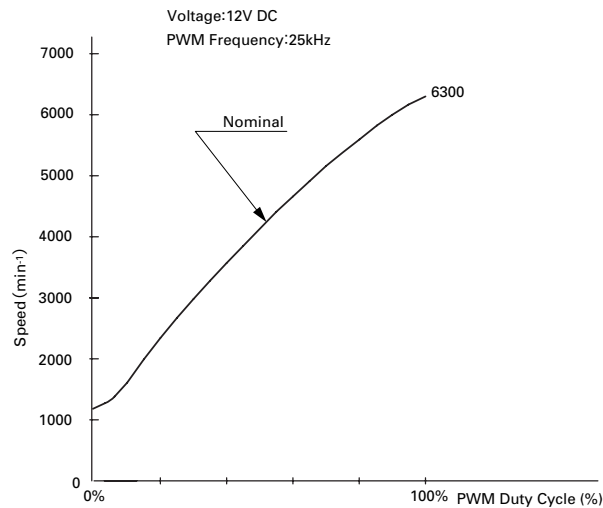

#### PWM Input Signal Example

Input Signal Wave Form : TTL Totem-pole

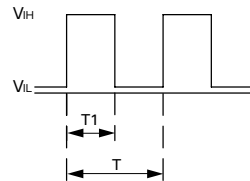

$V_{IH} = 4.75 \text{ V} \sim 5.25 \text{ V}$

$V_{IL} = 0 \text{ V} \sim 0.4 \text{ V}$

$\text{PWM Duty Cycle}(\%) = \frac{T_1}{T} \times 100$

$\text{PWM Frequency } 25 \text{ (kHz)} = \frac{1}{T}$

Source Current : 1mA Max. at control voltage 0V†

Sink Current : 1mA Max. at control voltage 5.25V†

Control Terminal Voltage : 5.25V Max. ( Open Circuit )†

#### Application

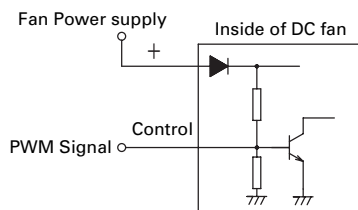

#### Dimensions (unit : mm)

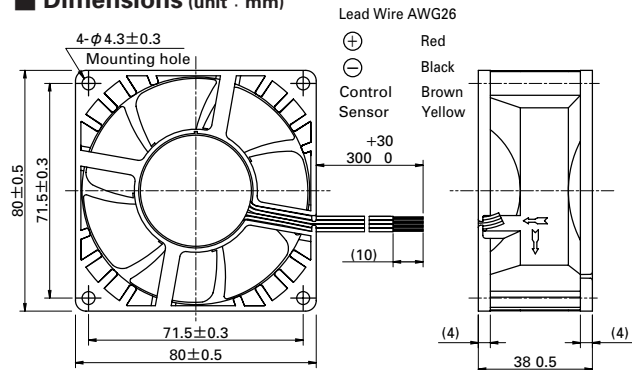

## Endurance Fan Series

SANYO DENKI's Cooling Fans enjoy wide acceptance by many customers thanks to their high performance and reliability, proven over many years. Within the company's line of Cooling Fan products, the " Endurance Fan Series " has been developed as a product suitable for a wide range of harsh environments.

The cooling fan motors in SANYO DENKI's " Endurance Fan Series " product line have been developed to perform in various demanding environments, and these motors are durable enough to withstand oil splashes, be installed in outdoor environments exposed to water, and operate non-stop for up to 200,000 hours.

The " Endurance Fan Series" products are capable of cooling the components of a variety of equipment, such as general industrial machinery, equipment installed in outdoor locations, and equipment that is operated for long durations with little or no maintenance.





## Oil Proof Fans

DC Fan  
San Ace WF Series

40mm sq. × 20mm thickness
60mm sq. × 25mm thickness
120mm sq. × 38mm thickness

Oil resistant materials protect coils and electronic parts.

Therefore, even in a severe environment with oil mist, the product maintains stable operation.

Life expectancy : 40,000 hours.

Applications : All kinds of industrial machines

Usage of this product requires an evaluation with the oil that will be used.

### "IP XX" Protection Grade

■ IP code is laid down in "Degrees of protection provided by enclosures (IP Code)" on JIS C 0920 and IEC 60529.

■ IP code is defined as "A coding system to indicate the degree of protection provided by an enclosure against access to hazardous parts, ingress of solid foreign objects, ingress of water and to give additional information in connection with such a protection"

■ Regarding IP code, the first numeral indicates the degree of protection against access to hazardous parts and ingress of solid foreign objects. The second numeral indicates the degree of protection against the ingress of water.

IP X X

**4: Protected against splashing water**

(Water splashed against the enclosure from any direction shall have no harmful effects)

**5: Protected against water jets**

(Water projected in jets against the enclosure from any direction shall have no harmful effects)

**5: Dust-Protected**

(Ingress of dust is not totally prevented, but dust shall not penetrate in a quantity to interfere with satisfactory operation of the apparatus or to impair safety.)

## Lineup of Endurance Fan Series

### Splash Proof Fans



DC Fan  
San Ace W Series

60mm sq. × 25mm thickness
80mm sq. × 25mm thickness
92mm sq. × 25mm thickness
120mm sq. × 38mm thickness
140mm sq. × 38mm thickness
140mm sq. × 51mm thickness

#### For IP55\*

This cooling fan operates with dependability even in the most severe environments, and is capable of resisting direct jets of water from multiple directions.

Life expectancy : 40,000 to 100,000 hours.

Applications : Outdoor equipment, and all kinds of general manufacturing equipment.

### Splash Proof Fans



DC Fan  
San Ace WS Series

80mm sq. × 25mm thickness
92mm sq. × 25mm thickness
120mm sq. × 38mm thickness

#### For IP54\*

It also offers reliable performance in environments where it is subject to water splash or spray from multiple directions.

Life expectancy : 40,000 hours.

Applications : Communications base station, Outdoor equipment, and all kinds of general manufacturing equipment.

## Long Life Fan

DC Fan  
San Ace L Series



40mm sq. × 28mm thickness
60mm sq. × 25mm thickness
80mm sq. × 25mm thickness
92mm sq. × 25mm thickness
120mm sq. × 38mm thickness
140mm sq. × 38mm thickness
140mm sq. × 51mm thickness
φ 172mm × 51mm thickness (sidecut type) (round type)

The Long-Life Fan Series for cooling equipment that must be in operation and maintenance-free for long periods of time.

Life expectancy : 60,000~200,000 hours

Applications : Communications equipment etc





# DC FAN

# DC Fan

## Domain diagram

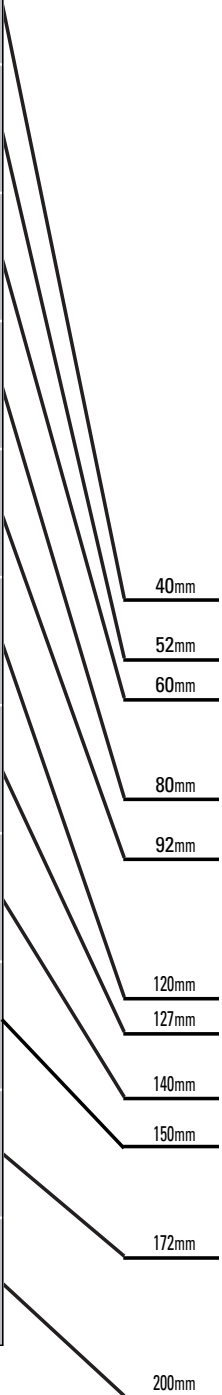
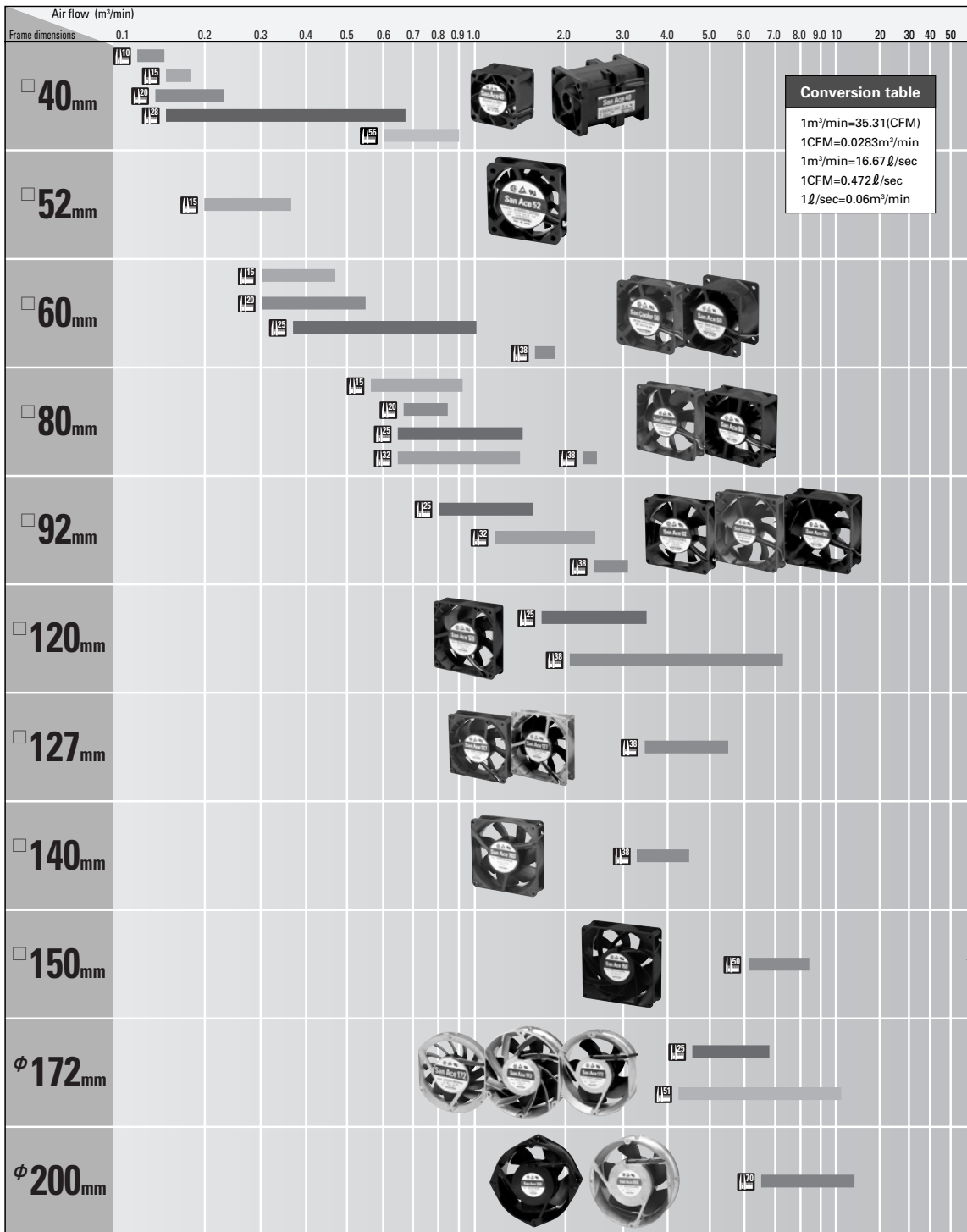

# DC Fan

## 40mm San Ace 40



### General specifications

Material .....Frame, Impeller:Plastics  
 Life Expectancy .....Varies for each model (Survival rate: 90% at 60°C,  
 rated voltage,and continuously run in a free air state)  
 Motor Protection System ....Current blocking function (with reverse polarity protection)  
 Dielectric Strength .....50/60 Hz, 500VAC, 1 minute (between lead conductor and frame)  
 Operating Temperature Range .....Varies for each model (Non-condensing)  
 Lead Wire .....S, H speeds ⊕red, ⊖black  
 M speed ⊕red, ⊖black or blue  
 Mass .....19g (10mm thick) 32g (15mm thick)

### 10mm thick Specifications

Model No.	Rated Voltage (V)	Operating Voltage Range (V)	Rated Current (A)	Rated Input (W)	Rated Speed (min <sup>-1</sup> )	Air Flow (m <sup>3</sup> /min) (CFM)	Static Pressure (Pa) (inchH <sub>2</sub> O)	Noise (dB [A])	Operating Temperature Range (°C)	Life Expectancy (h)
109P0405H902	5	4.5~ 5.5	0.16	0.8	6,200	0.15 5.3	41.16 0.165	25	-10 ~ +60	40,000
109P0405M902			0.11	0.55	5,000	0.12 4.2	26.95 0.108	21		
109P0412H902	12	7 ~13.8	0.07	0.84	6,200	0.15 5.3	41.16 0.165	25		
109P0412M902			0.06	0.72	5,000	0.12 4.2	26.95 0.108	21		

### Air Flow and Static Pressure Characteristics

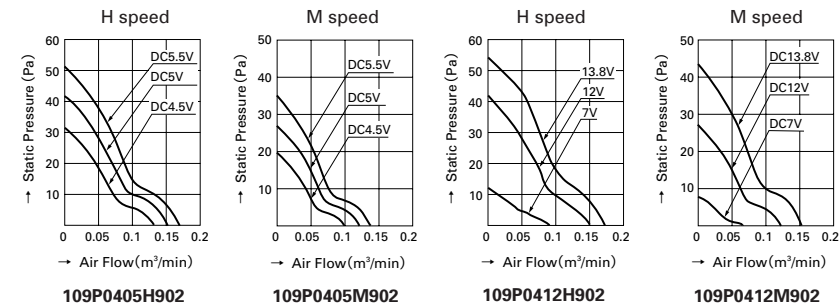

40mm

### 15mm thick Specifications

Model No.	Rated Voltage (V)	Operating voltage range (V)	Rated current (A)	Rated Input (W)	Rated Speed (min <sup>-1</sup> )	Air Flow (m <sup>3</sup> /min) (CFM)	Static pressure (Pa) (inchH <sub>2</sub> O)	Noise (dB [A])	Operating Temperature Range (°C)	Life expectancy (h)
109P0405H702	5	4.5~ 5.5	0.28	1.4	7,700	0.18 6.4	75.5 0.303	28	-10 ~ +60	60,000
109P0405M702			0.21	1.05	6,500	0.15 5.3	53 0.213	24		
109P0412S702	12	10.2~13.8	0.18	2.16	8,600	0.2 7.06	92.1 0.369	32		
109P0412H702			0.13	1.56	7,700	0.18 6.4	75.5 0.303	28		
109P0412M702			0.095	1.14	6,500	0.15 5.3	53 0.213	24		
109P0424H702	24	20.4~27.6	0.08	1.92	7,700	0.18 6.4	75.5 0.303	28		

### Air Flow and Static Pressure Characteristics

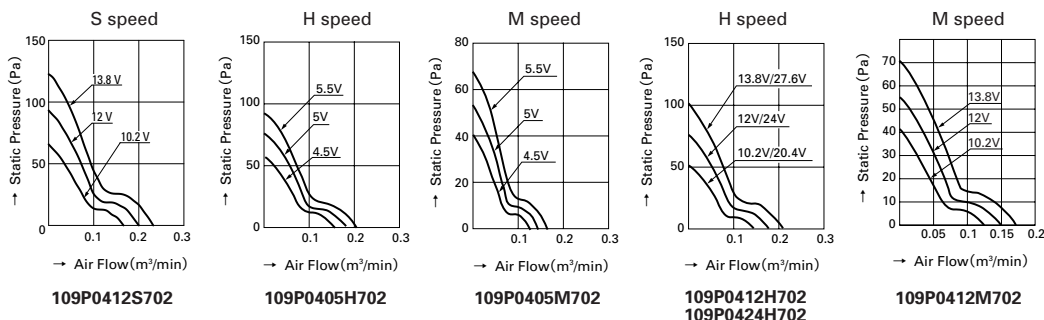

**Dimensions (unit : mm)**

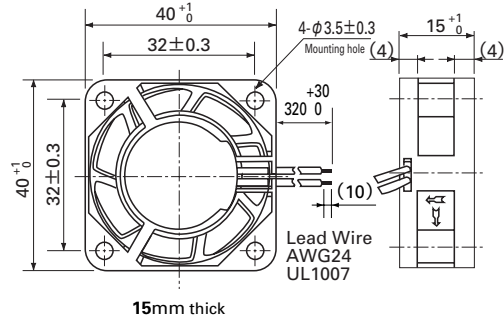
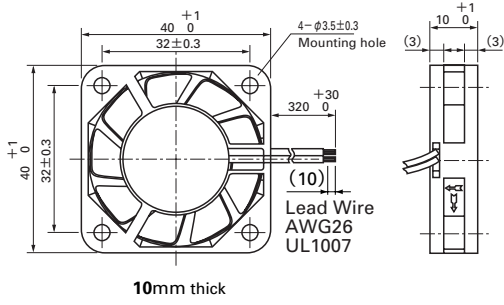

**Reference dimension of mounting holes and vent opening (unit : mm)**

Air inlet side · Air outlet side

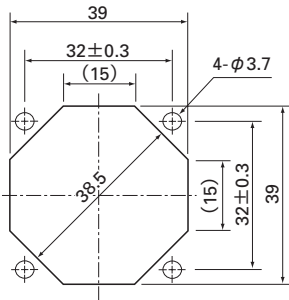

# DC Fan

# 40mm San Ace 40



## General specifications

- Material .....Frame, Impeller:Plastics
- Life Expectancy .....Varies for each model (Survival rate: 90% at 60°C, rated voltage,and continuously run in a free air state)
- Motor Protection System .....Current blocking function (with reverse polarity protection)
- Dielectric Strength .....50/60 Hz, 500VAC, 1 minute (between lead conductor and frame)
- Operating Temperature Range .....Varies for each model (Non-condensing)
- Lead Wire .....H, F, G, B speeds ⊕red, ⊖black  
M speed ⊕red, ⊖black or blue
- Mass .....45g (20mm thick) 52g (28mm thick)

## 20mm thick Specifications

Model No.	Rated Voltage (V)	Operating Voltage Range (V)	Rated Current (A)	Rated Input (W)	Rated Speed (min <sup>-1</sup> )	Air Flow (m <sup>3</sup> /min) (CFM)	Static Pressure (Pa) (inchH <sub>2</sub> O)	Noise (dB [A])	Operating Temperature Range (°C)	Life Expectancy (h)	
109P0405H602	5	4.5~ 5.5	0.32	1.6	8,000	0.225 8.0	65.7 0.264	33	-10 ~+70	40,000	
109P0405F602			0.25	1.25	6,500	0.183 6.5	45.1 0.181	28			
109P0405M602			0.12	0.60	5,000	0.136 4.8	26.5 0.106	24			
109P0412G602	12	7 ~13.8	0.28	3.36	12,500	0.35 12.4	153.8 0.618	44	-10 ~+60	40,000	
109P0412H602			0.11	1.32	8,000	0.225 8.0	65.7 0.264	33			
109P0412F602			0.09	1.08	6,500	0.183 6.5	45.1 0.181	28			
109P0412M602	24	8 ~13.8	0.06	0.72	5,000	0.136 4.8	26.5 0.106	24	-10 ~+70	60,000	
109P0424H602			12 ~27.6	0.07	1.68	8,300	0.233 8.2	69.6 0.280			35
109P0424F602			14 ~27.6	0.06	1.44	6,500	0.183 6.5	45.1 0.181			28

## Air Flow and Static Pressure Characteristics

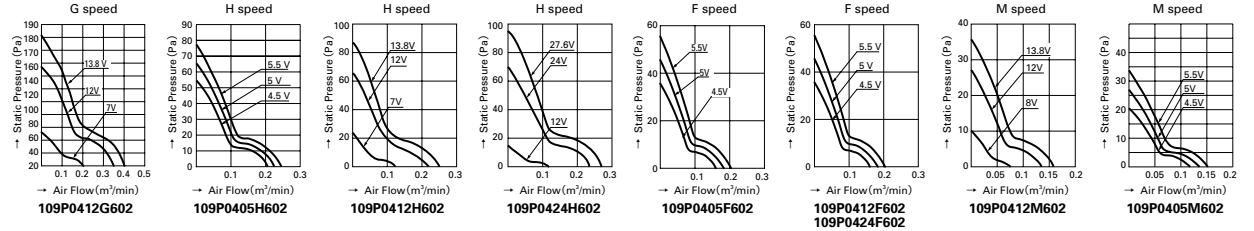

40mm

## 28mm thick Specifications

Model No.	Rated Voltage (V)	Operating Voltage Range (V)	Rated Current (A)	Rated Input (W)	Rated Speed (min <sup>-1</sup> )	Air Flow (m <sup>3</sup> /min) (CFM)	Static Pressure (Pa) (inchH <sub>2</sub> O)	Noise (dB [A])	Operating Temperature Range (°C)	Life Expectancy (h)	
109P0405H302	5	4.5~5.5	0.68	3.4	8,700	0.32 11.3	103 0.414	37	-10 ~+70	40,000	
109P0405F302			0.28	1.4	6,700	0.244 8.6	58.8 0.236	30			
109P0412G302	12	7~13.2	0.31	3.72	11,500	0.42 14.8	179 0.719	42	-10 ~+60	40,000	
109P0412B302			0.28	3.36	10,300	0.38 13.4	143 0.574	40			
109P0412H302			0.195	2.34	8,700	0.32 11.3	103 0.414	37			
109P0412F302	24	10.2~13.8	0.105	1.26	6,700	0.244 8.6	58.8 0.236	30	-10 ~+70	60,000	
109P0412M302			0.045	0.54	4,100	0.15 5.3	21.6 0.087	20			
109P0424G302			12~26.4	0.19	4.56	11,500	0.42 14.8	179 0.719			42
109P0424B302	24	12~27.6	0.13	3.12	10,300	0.38 13.4	143 0.574	40	-10 ~+60	40,000	
109P0424H302			12~27.6	0.095	2.28	8,700	0.32 11.3	103 0.414			37
109P0424F302			14~27.6	0.055	1.32	6,700	0.244 8.6	58.8 0.236			30

## Air Flow and Static Pressure Characteristics

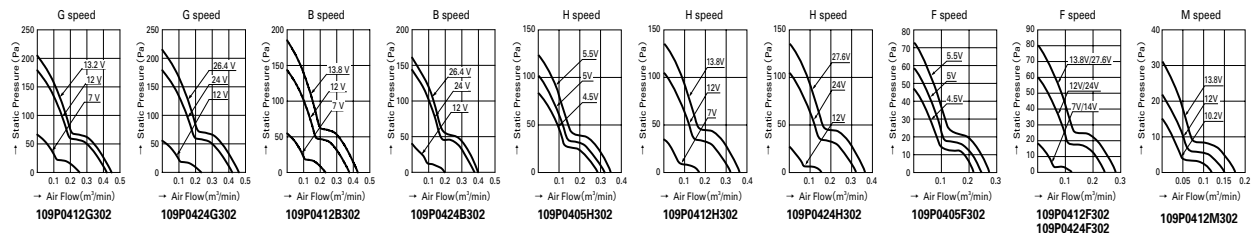

**Dimensions (unit : mm)**

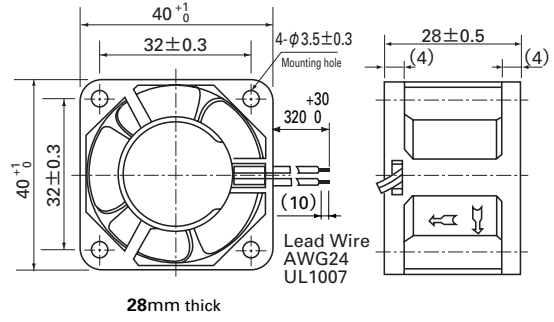
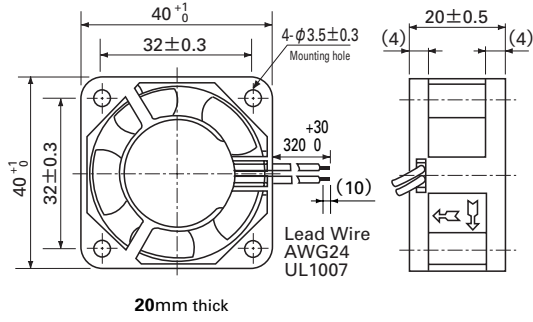

**Reference dimension of mounting holes and vent opening (unit : mm)**

Air inlet side · Air outlet side

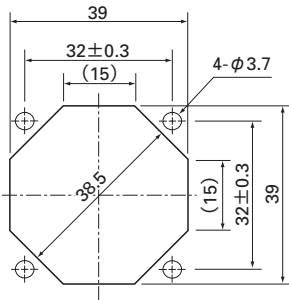

## DC Fan

**40mm**  
San Ace 40



"San Ace 40" GV type

### General specifications

- Material .....Frame, impeller : Plastics
- Life Expectancy .....Varies for each model (Survival rate: 90% at 60°C, rated voltage, and continuously run in a free air state)
- Motor Protection System .....Current blocking function (with reverse polarity protection)
- Dielectric Strength .....50/60 Hz, 500VAC, 1 minute (between lead conductor and frame)
- Noise Measurement Method .....Measured at 1m from the air inlet
- Operating Temperature Range .....Varies for each model (Non-condensing)
- Lead Wire .....⊕red, ⊖black
- Mass .....50g

## 28mm thick Specifications

Model No.	Rated Voltage (V)	Operating Voltage range (V)	Rated Current (A)	Rated Input (W)	Rated Speed (min <sup>-1</sup> )	Air Flow (m <sup>3</sup> /min) (CFM)	Static Pressure (Pa) (inchH <sub>2</sub> O)	Noise (dB [A])	Operating Temperature Range (°C)	Life Expectancy (h)
<b>9GV0412J302(3021)</b>	12	7~13.2	0.60	7.20	14,700	0.68 24.0	330 1.325	55	-10 ~ +60	40,000
<b>9GV0412G302(3021)</b>			0.47	5.64	13,000	0.60 21.1	260 1.044	52		

The numbers in ( ) represent ribless models.

### Air Flow and Static Pressure Characteristics

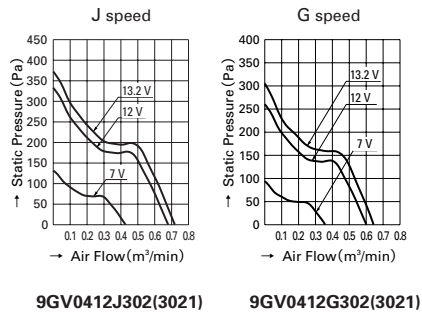

40mm

**Dimensions (unit : mm)**

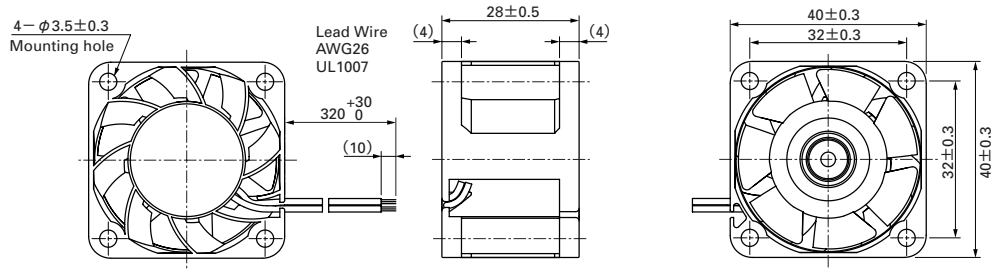

**Reference dimension of mounting holes and vent opening (unit : mm)**

Air inlet side · Air outlet side

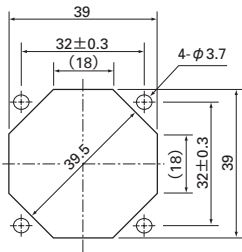





### Air Flow and Static Pressure Characteristics

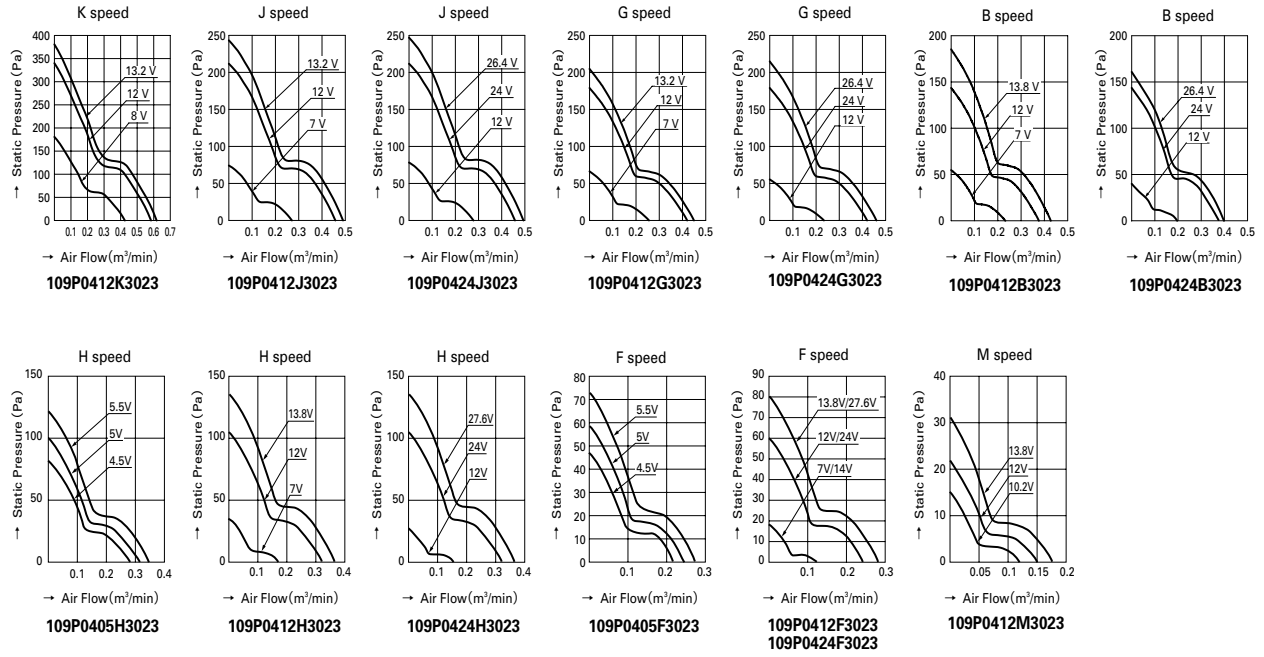

### Dimensions (unit : mm)

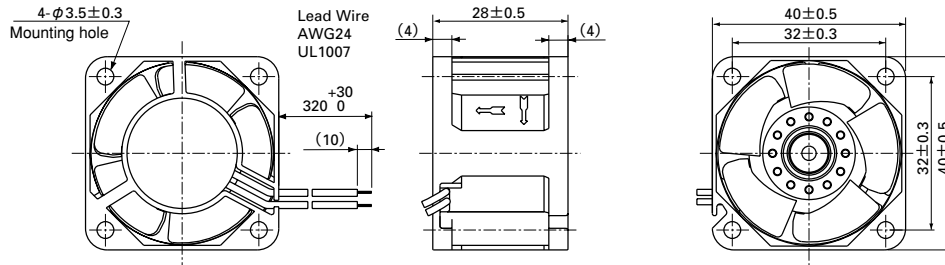

40mm

### Reference dimension of mounting holes and vent opening (unit : mm)

Air inlet side · Air outlet side

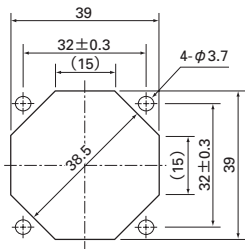



**Dimensions (unit : mm)**

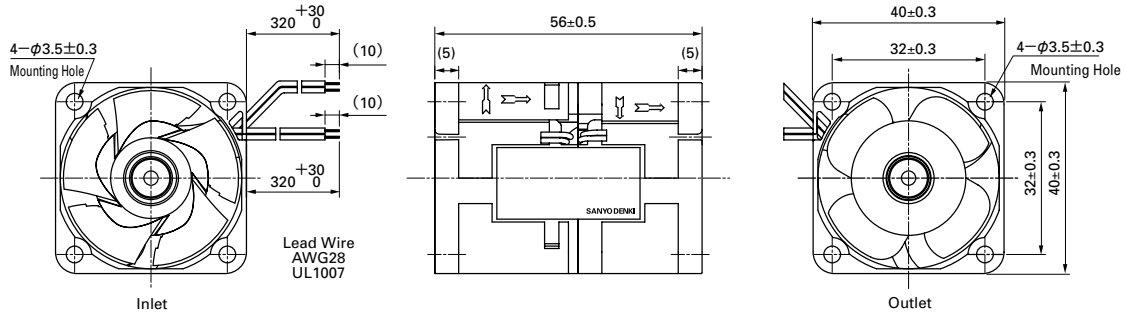

**Reference Dimension of Mounting Holes and Vent Opening (unit : mm)**

Air Inlet Side · Air Outlet Side

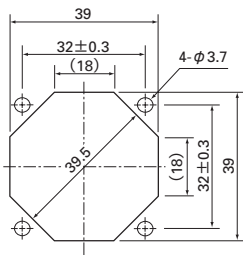



**Dimensions (unit : mm)**

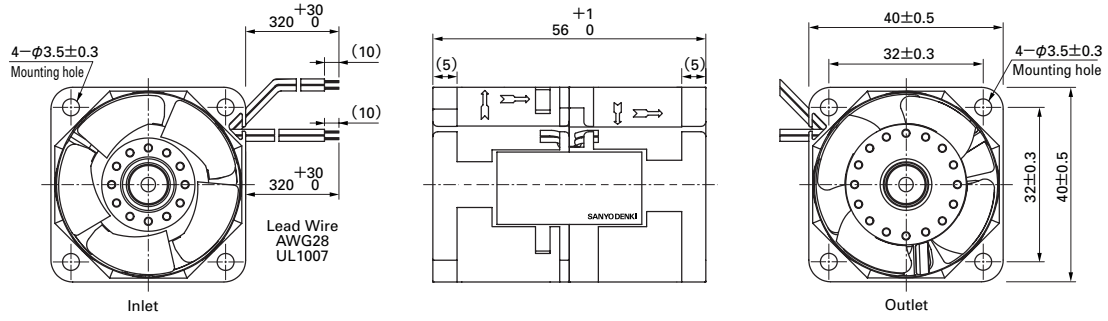

**Reference dimension of mounting holes and vent opening (unit : mm)**

Air inlet side · Air outlet side

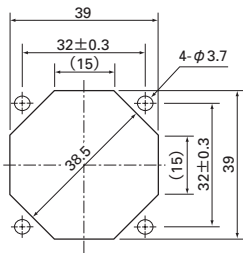



**Dimensions (unit : mm)**

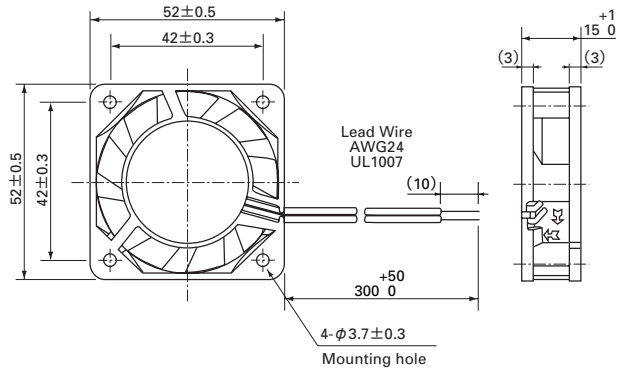

**Reference dimension of mounting holes and vent opening (unit : mm)**

Air inlet side · Air outlet side

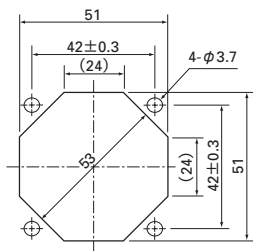

52mm





# 25mm thick Specifications

Model No.	Rated Voltage (V)	Operating Voltage Range (V)	Rated Current (A)	Rated Input (W)	Rated Speed (min <sup>-1</sup> )	Air Flow (m <sup>3</sup> /min) (CFM)	Static Pressure (Pa) (inchH <sub>2</sub> O)	Noise (dB [A])	Operating Temperature Range (°C)	Life Expectancy (h)				
109R0605H402(4021)	5	4.5~5.5	0.34	1.70	3,800	0.53 20.5	40.2 0.161	28	-10 ~ +70	60,000				
109R0605F402(4021)			0.20	1.00	3,200	0.44 15.5	29.4 0.118	24						
109R0605M402(4021)			0.13	0.65	2,600	0.36 12.7	19.6 0.079	20						
109R0612J402(4021)	12	10.8~13.2	0.47	5.64	7,600	1.05 37.1	155.0 0.622	44	-10 ~ +60	40,000				
109R0612G402(4021)			0.24	2.88	5,600	0.78 27.5	88.0 0.353	39						
109R0612D402(4021)			0.21	2.52	5,150	0.72 25.4	73.5 0.295	37						
109R0612S402(4021)	12	10.2~13.8	0.17	2.04	4,600	0.65 23.0	56.8 0.228	33	-10 ~ +70	60,000				
109R0612H402(4021)			0.11	1.32	3,800	0.53 18.7	40.2 0.161	28						
109R0612F402(4021)			0.09	1.08	3,200	0.44 15.5	29.4 0.118	24						
109R0612M402(4021)	12	7~13.8	0.06	0.72	2,600	0.36 12.7	19.6 0.079	20	-10 ~ +70	60,000				
109R0624J402(4021)			24	12~27.6	0.24	5.76	7,600	1.05 37.1			155.0 0.622	44	-10 ~ +60	40,000
109R0624G402(4021)					0.13	3.12	5,600	0.78 27.5			88.0 0.353	39		
109R0624D402(4021)	0.12	2.88			5,150	0.72 25.4	73.5 0.295	37						
109R0624S402(4021)	24	12~27.6	0.08	1.92	4,600	0.65 23.0	56.8 0.228	33	-10 ~ +70	60,000				
109R0624H402(4021)			0.06	1.44	3,800	0.53 18.7	40.2 0.161	28						
109R0624F402(4021)			0.05	1.20	3,200	0.44 15.5	29.4 0.118	24						
109R0624M402(4021)	24	14~27.6	0.04	0.96	2,600	0.36 12.7	19.6 0.079	20	-10 ~ +70	60,000				
109R0648J402(4021)			48	43.2~52.8	0.12	5.76	7,600	1.05 37.1			155.0 0.622	44	-10 ~ +60	40,000
109R0648G402(4021)					0.07	3.36	5,600	0.78 27.5			88.0 0.353	39		
109R0648H402(4021)	0.04	1.92			3,800	0.53 18.7	40.2 0.161	28						

The numbers in ( ) represent ribless models.

## Air Flow and Static Pressure Characteristics

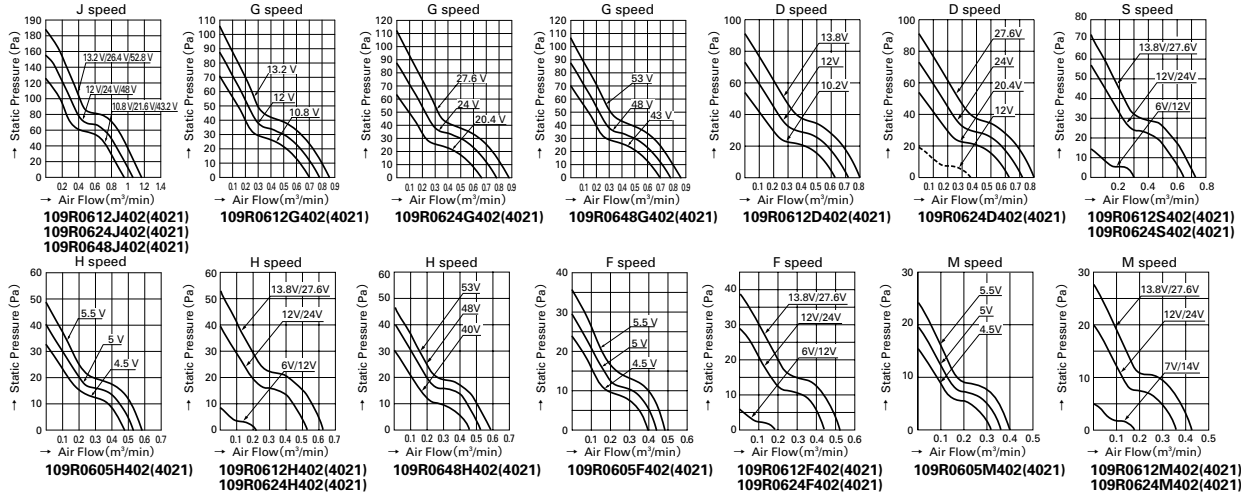

60mm

## Dimensions (unit : mm)

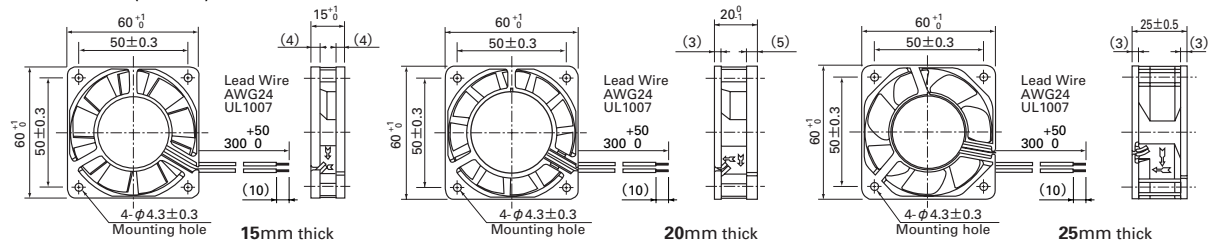

## Reference dimension of mounting holes and vent opening (unit : mm)

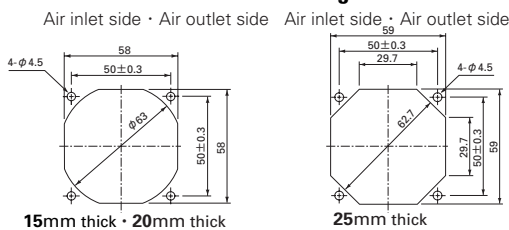

## DC Fan

□ **60mm**  
San Ace 60



ECO PRODUCTS



### General specifications

- Material .....Frame, impeller : Plastics
- Life Expectancy .....Varies for each model (Survival rate: 90% at 60°C, rated voltage, and continuously run in a free air state)
- Motor Protection System .....Current blocking function (with reverse polarity protection)
- Dielectric Strength .....50/60 Hz, 500VAC, 1 minute (between lead conductor and frame)
- Noise Measurement Method .....Measured at 1m from the air inlet
- Operating Temperature Range .....Varies for each model (Non-condensing)
- Lead Wire .....⊕red, ⊖black
- Mass .....110g

### 38mm thick Specifications

Model No.	Rated Voltage (V)	Operating Voltage Range (V)	Rated Current (A)	Rated Input (W)	Rated Speed (min <sup>-1</sup> )	Air Flow (m <sup>3</sup> /min) (CFM)	Static Pressure (Pa) (inchH <sub>2</sub> O)	Noise (dB [A])	Operating Temperature Range (°C)	Life Expectancy (h)
<b>9G0612G102(1021)</b>	12	7.0~13.8	1.54	18.5	11,800	1.84 65	435 1.747	58	-10 ~ +70	40,000
<b>9G0612S102(1021)</b>			1.36	16.3	10,800	1.70 60	370 1.486	56		
<b>9G0624G102(1021)</b>	24	14.0~27.6	0.85	20.4	11,800	1.84 65	435 1.747	58		
<b>9G0624S102(1021)</b>			0.70	16.8	10,800	1.70 60	370 1.486	56		
<b>9G0648G102(1021)</b>	48	28 ~55.2	0.35	16.8	11,800	1.84 65	435 1.747	58		
<b>9G0648S102(1021)</b>			0.29	13.9	10,800	1.70 60	370 1.486	56		

The numbers in ( ) represent ribless models.

### Air Flow and Static Pressure Characteristics

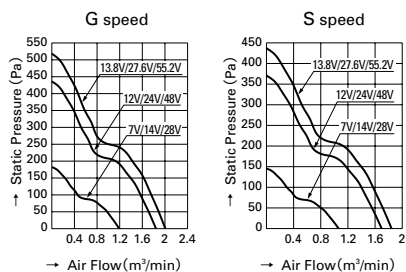

**9G0612G102(1021)**      **9G0612S102(1021)**  
**9G0624G102(1021)**      **9G0624S102(1021)**  
**9G0648G102(1021)**      **9G0648S102(1021)**

60mm

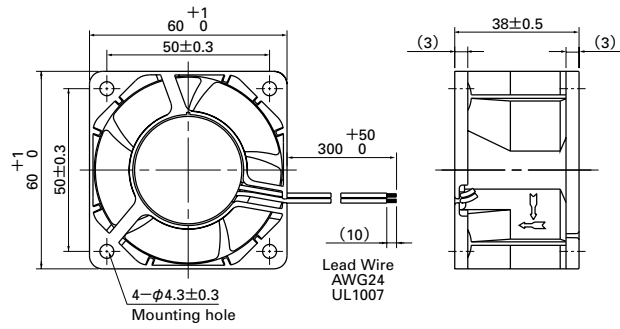
**Dimensions (unit : mm)****Reference dimension of mounting holes and vent opening (unit : mm)**

Air inlet side · Air outlet side

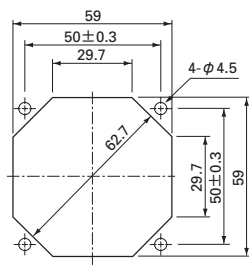
60mm

# DC Fan

## 80mm San Ace 80



### General specifications

Material .....Frame, Impeller:Plastics  
 Life Expectancy .....Varies for each model (Survival rate: 90% at 60°C,  
 rated voltage,and continuously run in a free air state)  
 Motor Protection System .....Current blocking function (with reverse polarity protection)  
 Dielectric Strength .....50/60 Hz, 500VAC, 1 minute (between lead conductor and frame)  
 Noise Measurement Method .....Measured at 1m from the air inlet  
 Operating Temperature Range .....Varies for each model (Non-condensing)  
 Lead Wire .....K, G, A, S, H, F ,W speeds ⊕red, ⊖black  
 M, L speeds ⊕red, ⊖black or blue  
 Mass .....68g (15mm thick) 100g (20mm thick)  
 110g (25mm thick) 150g (32mm thick)

### 15mm thick Specifications

Model No.	Rated Voltage (V)	Operating Voltage Range (V)	Rated Current (A)	Rated Input (W)	Rated Speed (min <sup>-1</sup> )	Air Flow (m <sup>3</sup> /min) (CFM)	Static Pressure (Pa) (inchH <sub>2</sub> O)	Noise (dB [A])	Operating Temperature Range (°C)	Life Expectancy (h)
109P0812H702	12	7~13.8	0.2	2.4	3,100	0.91 32.1	29.4 0.118	31	-10 ~ +70	40,000
109P0812M702			0.09	1.08	2,000	0.57 20.1	12.6 0.051	21		60,000
109P0824H702	24	14~27.6	0.1	2.4	3,100	0.91 32.1	29.4 0.118	31		40,000
109P0824M702			0.05	1.2	2,000	0.57 20.1	12.6 0.051	21		60,000

### 20mm thick Specifications

Model No.	Rated Voltage (V)	Operating Voltage Range (V)	Rated Current (A)	Rated Input (W)	Rated Speed (min <sup>-1</sup> )	Air Flow (m <sup>3</sup> /min) (CFM)	Static Pressure (Pa) (inchH <sub>2</sub> O)	Noise (dB [A])	Operating Temperature Range (°C)	Life Expectancy (h)
109P0812H602	12	10.2~13.8	0.21	2.52	2,900	0.84 29.7	29.4 0.118	31	-10 ~ +70	60,000
109P0812M602			0.13	1.56	2,300	0.67 23.7	18.6 0.075	25		
109P0824H602	24	20.4~27.6	0.12	2.88	2,900	0.84 29.7	29.4 0.118	31		
109P0824M602			0.07	1.68	2,300	0.67 23.7	18.6 0.075	25		

Air Flow and Static Pressure Characteristics (15mm thick)

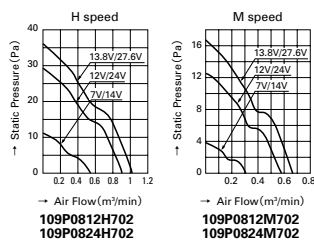

Air Flow and Static Pressure Characteristics (20mm thick)

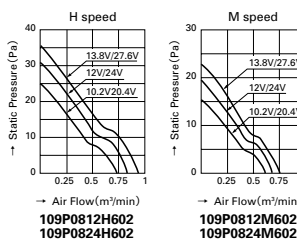

80mm

### 25mm thick Specifications

Model No.	Rated Voltage (V)	Operating Voltage Range (V)	Rated Current (A)	Rated Input (W)	Rated Speed (min <sup>-1</sup> )	Air Flow (m <sup>3</sup> /min) (CFM)	Static Pressure (Pa) (inchH <sub>2</sub> O)	Noise (dB [A])	Operating Temperature Range (°C)	Life Expectancy (h)	
109R0805F402(4021)	5	4.5~ 5.5	0.25	1.25	2,600	0.92 32.5	28.4 0.114	26	-10 ~ +70	60,000	
109R0805M402(4021)			0.17	0.85	2,350	0.83 29.3	22.5 0.090	23			
109R0812G402(4021)	12	10.8~13.2	0.37	4.44	4,500	1.50 53.0	80.4 0.323	40	-10 ~ +60	40,000	
109R0812S402(4021)			0.18	2.16	3,400	1.20 42.4	48.0 0.193	34			
109R0812H402(4021)			0.13	1.56	2,900	1.03 36.4	35.3 0.142	29			
109R0812F402(4021)			6 ~13.8	0.11	1.32	2,600	0.92 32.5	28.4 0.114			26
109R0812M402(4021)				0.09	1.08	2,350	0.83 29.3	22.5 0.090			23
109R0812L402(4021)				0.06	0.72	1,850	0.65 23.0	14.7 0.059			20
109R0824G402(4021)			24	20.4~26.4	0.20	4.80	4,500	1.50 53.0			80.4 0.323
109R0824S402(4021)	0.10	2.40			3,400	1.20 42.4	48.0 0.193	34			
109R0824H402(4021)	12 ~27.6	0.07			1.68	2,900	1.03 36.4	35.3 0.142	29		
109R0824F402(4021)		0.06			1.44	2,600	0.92 32.5	28.4 0.114	26		
109R0824M402(4021)		0.05			1.20	2,350	0.83 29.3	22.5 0.090	23		
109R0824L402(4021)	14 ~27.6	0.04			0.96	1,850	0.65 23.0	14.7 0.059	20		
109R0848K402(4021)	48	40.8~55.2			0.10	4.80	4,600	1.56 55.1	88.4 0.355	41	-10 ~ +60
109R0848S402(4021)			0.06	2.88	3,400	1.20 42.4	48.0 0.193	34			

The numbers in ( ) represent ribless models.

# 32mm thick Specifications

Model No.	Rated Voltage (V)	Operating Voltage Range (V)	Rated Current (A)	Rated Input (W)	Rated Speed (min <sup>-1</sup> )	Air Flow (m <sup>3</sup> /min) (CFM)	Static Pressure (Pa) (inchH <sub>2</sub> O)	Noise (dB [A])	Operating Temperature Range (°C)	Life Expectancy (h)
<b>109P0812A202(2021)</b>	12	6 ~13.2	0.56	6.72	4,600	1.52 53.7	91.1 0.366	45	-10 ~+55	40,000(+65°C)
<b>109P0812H202(2021)</b>		10.2~13.8	0.16	1.92	3,150	1.05 37.1	43.1 0.173	33	-10 ~+70	40,000
<b>109P0812M202(2021)</b>			0.07	0.84	2,000	0.65 23.0	18.5 0.074	21		60,000
<b>109P0824A202(2021)</b>	24	12 ~26.4	0.29	6.96	4,600	1.52 53.7	91.1 0.366	45	-10 ~+60	40,000
<b>109P0824H202(2021)</b>		20.4~27.6	0.09	2.16	3,150	1.05 37.1	43.1 0.173	33	-10 ~+70	40,000
<b>109P0824M202(2021)</b>			0.04	0.96	2,000	0.65 23.0	18.6 0.075	21		60,000
<b>109P0848H202(2021)</b>	48	43 ~53	0.06	2.88	3,350	1.10 38.9	50.9 0.204	35		40,000

The numbers in ( ) represent ribless models.

## Air Flow and Static Pressure Characteristics (25mm thick · 32mm thick)

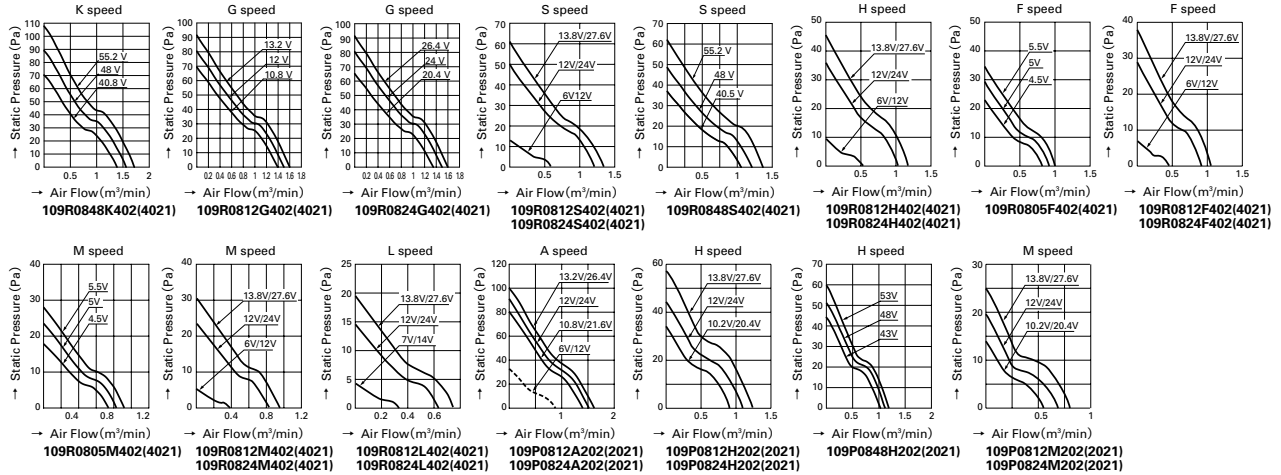

## Dimensions (unit : mm)

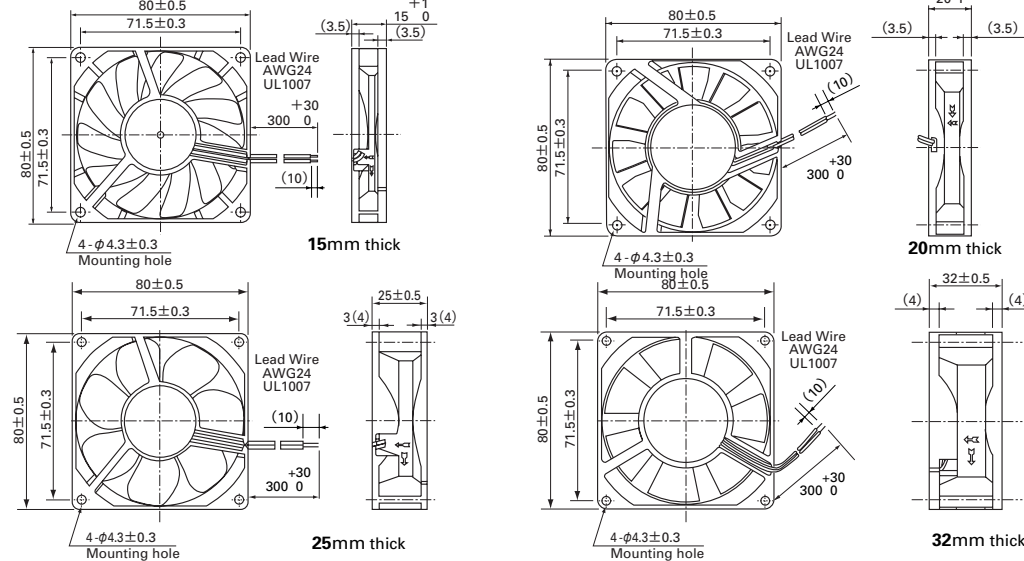

## Reference dimension of mounting holes and vent opening (unit : mm)

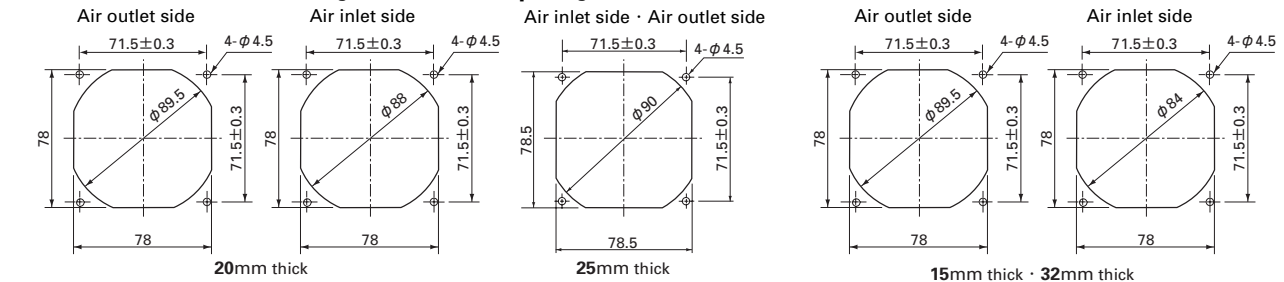

80mm

# DC Fan

80mm  
San Ace 80



## "San Ace 80" G Type

### General specifications

- Material .....Frame, Impeller:Plastics
- Life Expectancy .....Varies for each model (Survival rate: 90% at 60°C, rated voltage,and continuously run in a free air state)
- Motor Protection System ....Current blocking function (with reverse polarity protection)
- Dielectric Strength .....50/60 Hz, 500VAC, 1 minute (between lead conductor and frame)
- Noise Measurement Method ...Measured at 1m from the air inlet
- Operating Temperature Range .....Varies for each model (Non-condensing)
- Lead Wire .....⊕red, ⊖black
- Mass .....170g

## 38mm thick Specifications

Model No.	Rated Voltage (V)	Operating Voltage Range (V)	Rated Current (A)	Rated Input (W)	Rated Speed (min <sup>-1</sup> )	Air Flow (m <sup>3</sup> /min) (CFM)	Static Pressure (Pa) (inchH <sub>2</sub> O)	Noise (dB [A])	Operating Temperature Range (°C)	Life Expectancy (h)
<b>9G0812G102(1021)</b>	12	7 ~ 13.8	1.1	13.2	6,300	2.55 90	211 0.847	51	- 10 ~ +70	40,000
<b>9G0812H102(1021)</b>			0.9	10.8	5,700	2.28 80	171 0.687	49		
<b>9G0824G102(1021)</b>	24	20.4~27.6	0.56	13.4	6,300	2.55 90	211 0.847	51		
<b>9G0824H102(1021)</b>			0.42	10.1	5,700	2.28 80	171 0.687	49		
<b>9G0848G102(1021)</b>	48	40.8~55.2	0.27	13.0	6,300	2.55 90	211 0.847	51		
<b>9G0848H102(1021)</b>			0.20	9.6	5,700	2.28 80	171 0.687	49		

The numbers in ( ) represent ribless models.

### Air Flow and Static Pressure Characteristics

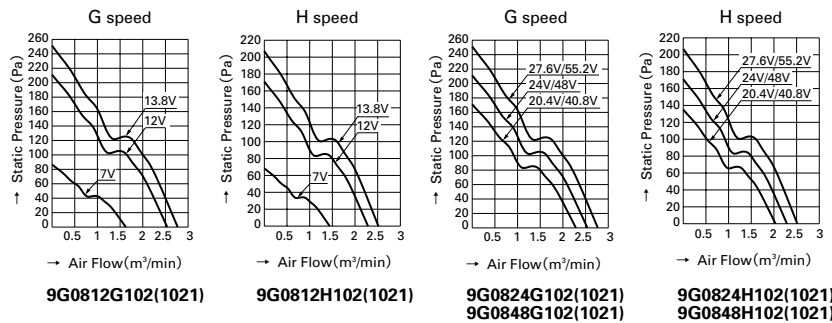

80mm

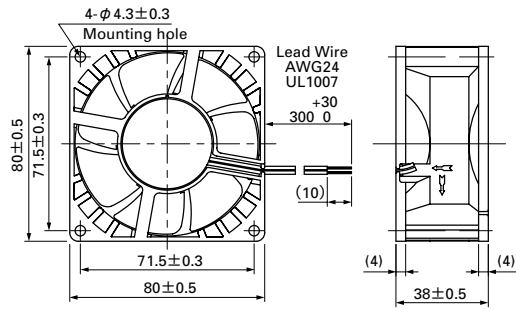
**Dimensions (unit : mm)****Reference dimension of mounting holes and vent opening (unit : mm)**

Air inlet side · Air outlet side

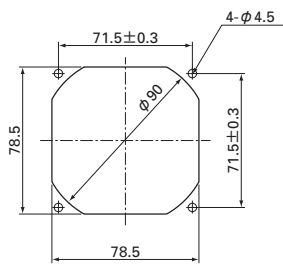
80mm





Model No.	Rated Voltage (V)	Operating Voltage Range (V)	Rated Current (A)	Rated Input (W)	Rated Speed (min <sup>-1</sup> )	Air Flow (m <sup>3</sup> /min) (CFM)	Static Pressure (Pa) (inchH <sub>2</sub> O)	Noise (dB [A])	Operating Temperature Range (°C)	Life Expectancy (h)
9G0912A202(2021)	12	10.2~13.8	0.58	6.96	4,300	2.50 88.3	115 0.462	44	-10 ~ +70	40,000
9G0912S202(2021)			0.38	4.56	3,500	2.00 70.7	77 0.309	38		
9G0912H202(2021)			0.23	2.76	2,850	1.59 56.2	51 0.205	32		
9G0912M202(2021)			0.13	1.56	2,100	1.20 42.4	27 0.108	25		
9G0924A202(2021)	24	20.4~27.6	0.30	7.20	4,300	2.50 88.3	115 0.462	44	-10 ~ +60	
9G0924S202(2021)			0.19	4.56	3,500	2.00 70.7	77 0.309	38		
9G0924H202(2021)			0.12	2.88	2,850	1.59 56.2	51 0.205	32		
9G0924M202(2021)			0.08	1.92	2,100	1.20 42.4	27 0.108	25		
9G0948A202(2021)	48	40.8~55.2	0.16	7.68	4,300	2.50 88.3	115 0.462	44	-10 ~ +70	
9G0948S202(2021)			0.11	5.28	3,500	2.00 70.7	77 0.309	38		
9G0948H202(2021)			0.08	3.84	2,850	1.59 56.2	51 0.205	32		
9G0948M202(2021)			0.05	2.40	2,100	1.20 42.4	27 0.108	25		

The numbers in ( ) represent ribless models.

## Air Flow and Static Pressure Characteristics

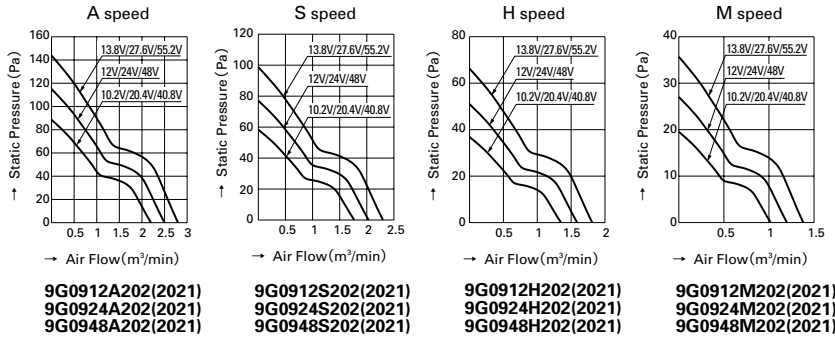

## Dimensions (unit : mm)

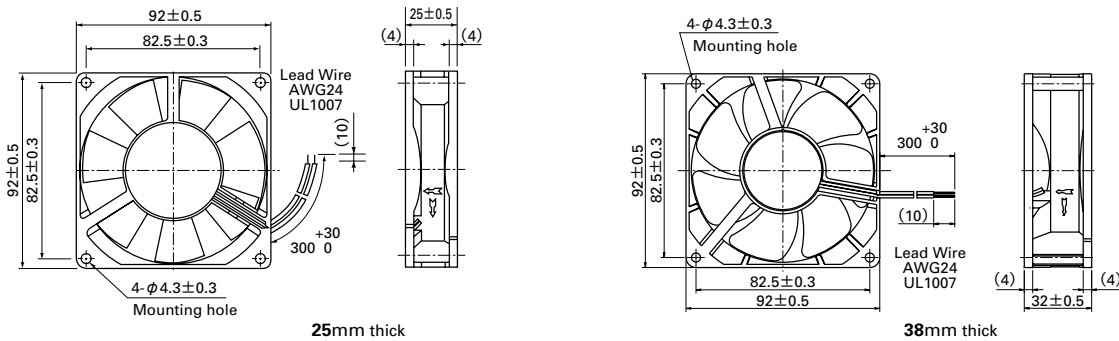

92mm

## Reference dimension of mounting holes and vent opening (unit : mm)

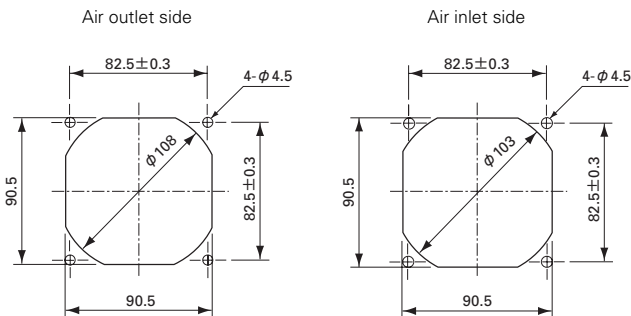

## DC Fan

92mm  
San Ace 92



### "San Ace 92" G Type

#### General specifications

Material .....Frame, Impeller:Plastics  
 Life Expectancy .....Varies for each model (Survival rate: 90% at 60°C,  
 rated voltage,and continuously run in a free air state)  
 Motor Protection System ....Current blocking function (with reverse polarity protection)  
 Dielectric Strength .....50/60 Hz, 500VAC, 1 minute (between lead conductor and frame)  
 Noise Measurement Method ...Measured at 1m from the air inlet  
 Operating Temperature Range .....Varies for each model (Non-condensing)  
 Lead Wire .....⊕red,⊖black  
 Mass .....180g

### 38mm thick Specifications

Model No.	Rated Voltage (V)	Operating Voltage Range (V)	Rated Current (A)	Rated Input (W)	Rated Speed (min <sup>-1</sup> )	Air Flow (m <sup>3</sup> /min) (CFM)	Static Pressure (Pa) (inchH <sub>2</sub> O)	Noise (dB [A])	Operating Temperature Range (°C)	Life Expectancy (h)
9G0912G102(1021)	12	7.0~13.8	1.1	13.2	5,000	3.10 110	150 0.602	50	-10 ~ +60	40,000
9G0912H102(1021)			0.58	6.96	4,000	2.54 90	100 0.402	43		
9G0924G102(1021)	24	20.4~27.6	0.55	13.2	5,000	3.10 110	150 0.602	50		
9G0924H102(1021)			0.3	7.2	4,000	2.54 90	100 0.402	43		
9G0948G102(1021)	48	40.8~55.2	0.27	12.96	5,000	3.10 110	150 0.602	50		
9G0948H102(1021)			0.16	7.68	4,000	2.54 90	100 0.402	43		

The numbers in ( ) represent ribless models.

### Air Flow and Static Pressure Characteristics

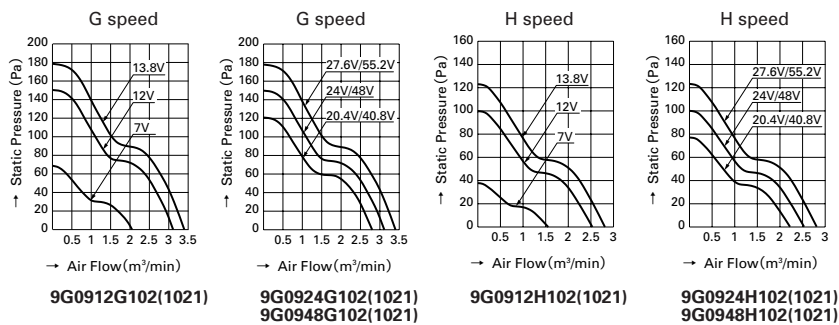

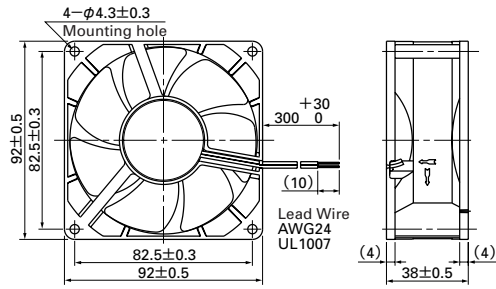
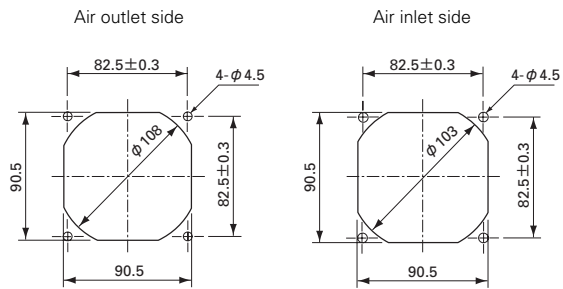
**Dimensions (unit : mm)****Reference dimension of mounting holes and vent opening (unit : mm)**

92mm



### Air Flow and Static Pressure Characteristics

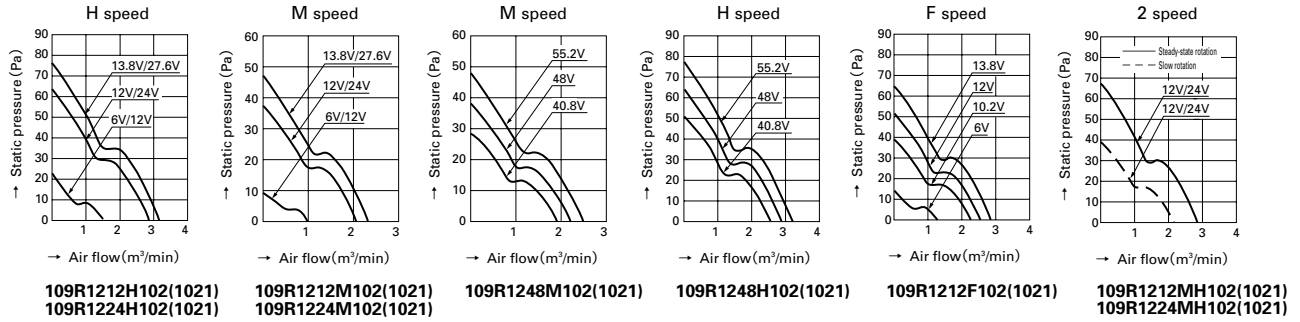

### Dimensions (unit : mm)

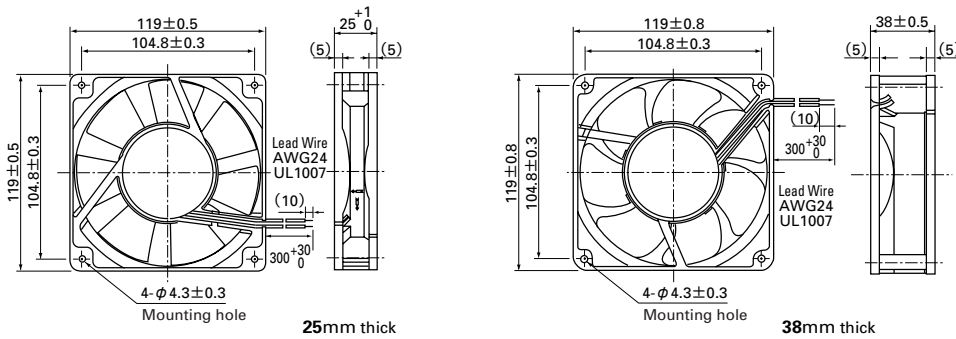

### Reference dimension of mounting holes and vent opening (unit : mm)

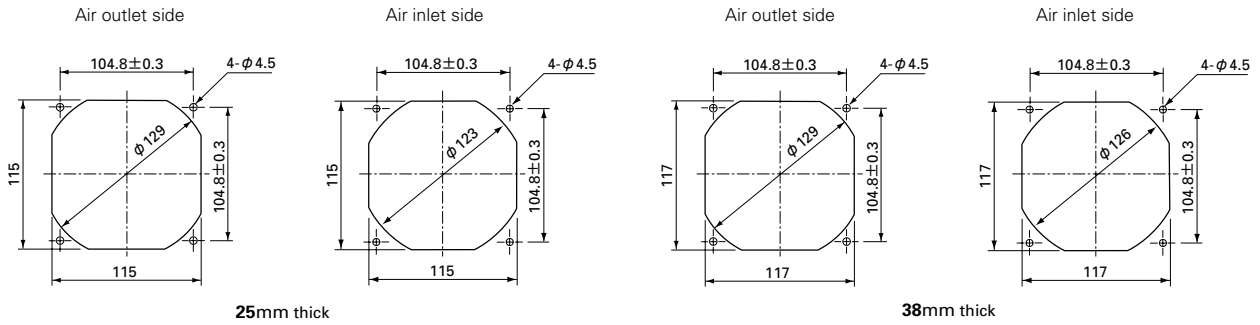

## DC Fan

120mm  
San Ace 120



ECO PRODUCTS



"San Ace 120" G type

### General specifications

- Material .....Frame, Impeller:Plastics
- Life Expectancy .....Varies for each model (Survival rate: 90% at 60°C, rated voltage,and continuously run in a free air state)
- Motor Protection System .....Current blocking function (with reverse polarity protection)
- Dielectric Strength .....50/60 Hz, 500VAC, 1 minute (between lead conductor and frame)
- Noise Measurement Method .....Measured at 1m from the air inlet
- Operating Temperature Range .....Varies for each model (Non-condensing)
- Lead Wire .....G, E, A, H, F speeds ⊕red,⊖black  
M speed ⊕red,⊖black or blue
- Mass .....240g

### 25mm thick Specifications

Model No.	Rated Voltage (V)	Operating Voltage Range (V)	Rated Current (A)	Rated Input (W)	Rated Speed (min <sup>-1</sup> )	Air Flow (m <sup>3</sup> /min) (CFM)		Static Pressure (Pa) (inchH <sub>2</sub> O)		Noise (dB [A])	Operating Temperature Range (°C)	Life Expectancy (h)
9G1212G402(4021)	12	10.2~13.8	0.90	10.8	4,100	3.68	130	120	0.482	51	-10 ~+70	40,000
9G1212E402(4021)			0.58	6.96	3,650	3.25	115	98	0.394	48		
9G1212A402(4021)			0.40	4.80	3,150	2.83	100	77	0.309	44		
9G1212H402(4021)		7 ~13.8	0.31	3.72	2,850	2.50	88	64	0.257	40		
9G1212F402(4021)			0.19	2.28	2,250	1.98	70	42	0.169	35		
9G1212M402(4021)			0.14	1.68	1,950	1.66	58	31	0.124	29		
9G1224G402(4021)	24	20.4~27.6	0.47	11.28	4,100	3.68	130	120	0.482	51		
9G1224E402(4021)			0.37	8.88	3,650	3.25	115	98	0.394	48		
9G1224A402(4021)			0.21	5.04	3,150	2.83	100	77	0.309	44		
9G1224H402(4021)		12 ~27.6	0.17	4.08	2,850	2.50	88	64	0.257	40		
9G1224F402(4021)			0.10	2.40	2,250	1.98	70	42	0.169	35		
9G1224M402(4021)			0.08	1.92	1,950	1.66	58	31	0.124	29		
9G1248G402(4021)	48	40.8~55.2	0.23	11.04	4,100	3.68	130	120	0.482	51		
9G1248E402(4021)			0.16	7.68	3,650	3.25	115	98	0.394	48		
9G1248A402(4021)			0.13	6.24	3,150	2.83	100	77	0.309	44		
9G1248H402(4021)			0.10	4.80	2,850	2.50	88	64	0.257	40		
9G1248F402(4021)			0.06	2.88	2,250	1.98	70	42	0.169	35		
9G1248M402(4021)			0.05	2.40	1,950	1.66	58	31	0.124	29		

The numbers in ( ) represent ribless models.

120mm

### Air Flow and Static Pressure Characteristics

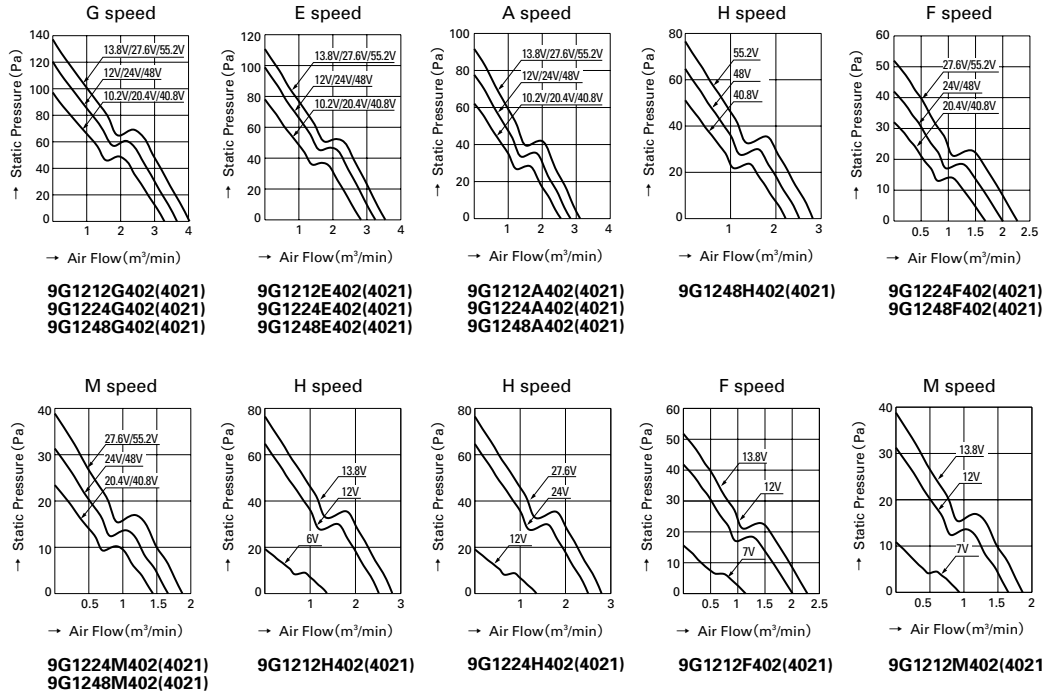

### Dimensions (unit : mm)

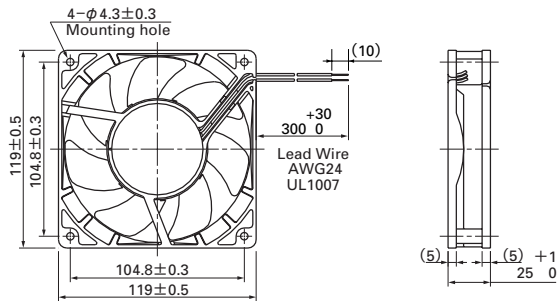

### Reference dimension of mounting holes and vent opening (unit : mm)

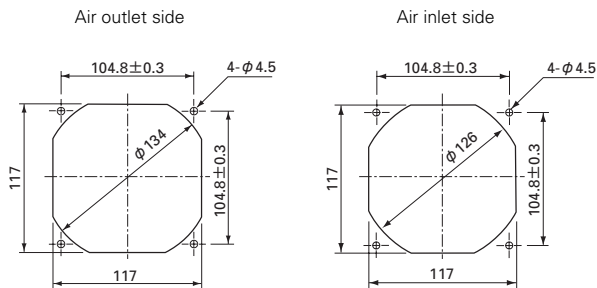

120mm

## DC Fan

□ **120mm**  
San Ace 120



### "San Ace 120" G type

#### General specifications

Material ..... Frame, Impeller:Plastics  
 Life Expectancy .....Varies for each model (Survival rate: 90% at 60°C,  
 rated voltage,and continuously run in a free air state)  
 Motor Protection System .....Current blocking function (with reverse polarity protection)  
 Dielectric Strength .....50/60 Hz, 500VAC, 1 minute (between lead conductor and frame)  
 Noise Measurement Method .....Measured at 1m from the air inlet  
 Operating Temperature Range .....Varies for each model (Non-condensing)  
 Lead Wire .....G, E, H, F speeds ⊕red,⊖black  
 M speed ⊕red,⊖black or blue  
 Mass .....330g

### 38mm thick Specifications

Model No.	Rated Voltage (V)	Operating Voltage Range (V)	Rated Current (A)	Rated Input (W)	Rated Speed (min <sup>-1</sup> )	Air Flow (m <sup>3</sup> /min) (CFM)		Static Pressure (Pa) (inchH <sub>2</sub> O)		Noise (dB [A])	Operating Temperature Range (°C)	Life Expectancy (h)
<b>9G1212G102(1021)</b>	12	10.2~13.8	0.98	11.76	3,600	3.88	137	135	0.542	49	-10 ~ +70	40,000
<b>9G1212E102(1021)</b>			0.61	7.32	3,100	3.34	118	100	0.402	46		
<b>9G1212H102(1021)</b>		7 ~13.8	0.38	4.56	2,600	2.80	99	70.4	0.283	39		
<b>9G1212F102(1021)</b>			0.28	3.36	2,280	2.45	87	54.2	0.218	36		
<b>9G1212M102(1021)</b>			0.21	2.52	1,950	2.10	74	39.6	0.159	32		
<b>9G1224G102(1021)</b>	24	20.4~27.6	0.50	12	3,600	3.88	137	135	0.542	49		
<b>9G1224E102(1021)</b>			0.34	8.16	3,100	3.34	118	100	0.402	46		
<b>9G1224H102(1021)</b>		14 ~27.6	0.22	5.28	2,600	2.80	99	70.4	0.283	39		
<b>9G1224F102(1021)</b>			0.16	3.84	2,280	2.45	87	54.2	0.218	36		
<b>9G1224M102(1021)</b>			0.11	2.64	1,950	2.10	74	39.6	0.159	32		
<b>9G1248G102(1021)</b>	48	40.8~55.2	0.25	12	3,600	3.88	137	135	0.542	49		
<b>9G1248E102(1021)</b>			0.17	8.16	3,100	3.34	118	100	0.402	46		
<b>9G1248H102(1021)</b>			0.11	5.28	2,600	2.80	99	70.4	0.283	39		
<b>9G1248F102(1021)</b>			0.09	4.32	2,280	2.45	87	54.2	0.218	36		
<b>9G1248M102(1021)</b>			0.07	3.36	1,950	2.10	74	39.6	0.159	32		

The numbers in ( ) represent ribless models.

120mm



### Air Flow and Static Pressure Characteristics

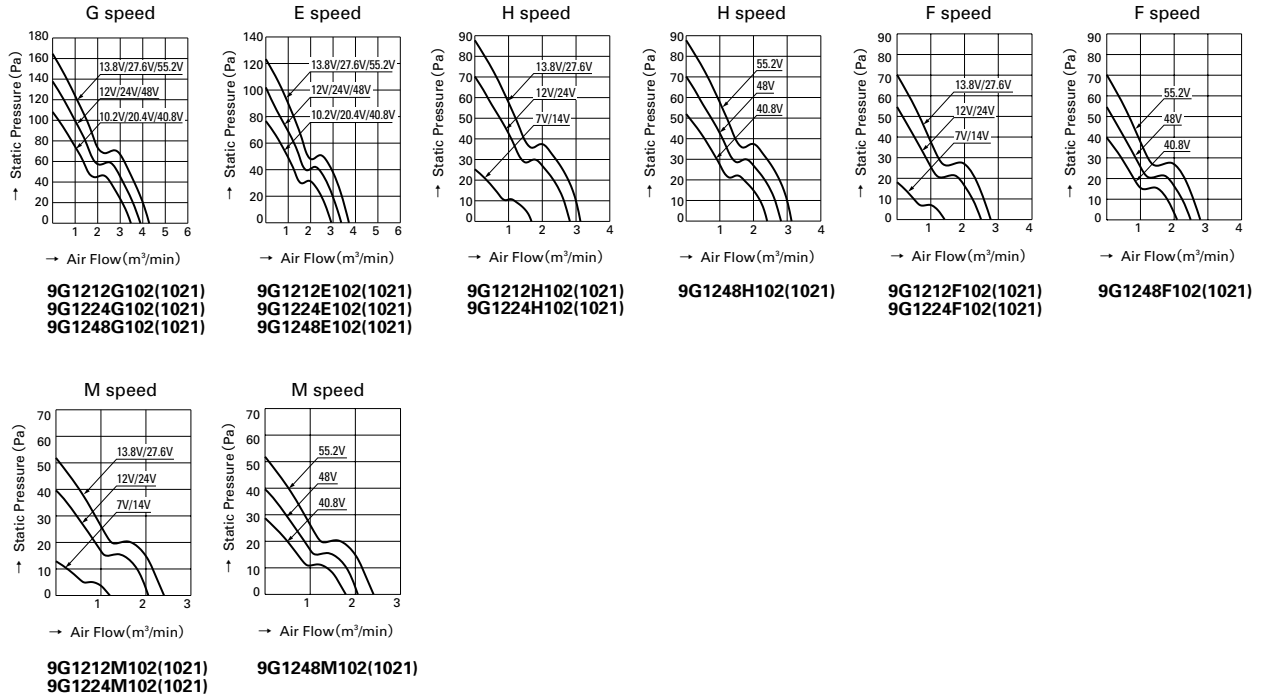

### Dimensions (unit : mm)

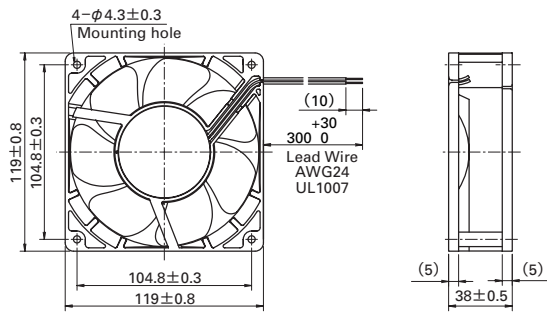

### Reference dimension of mounting holes and vent opening (unit : mm)

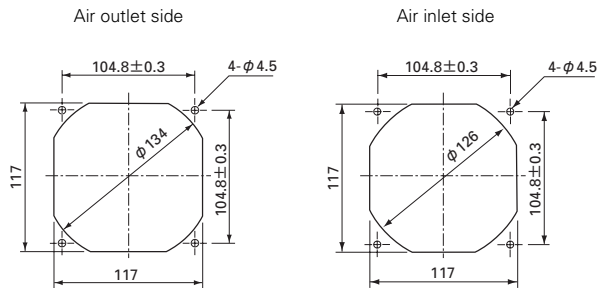

120mm

## DC Fan

□ **120mm**  
San Ace 120



"San Ace 120" SG type



ECO PRODUCTS

### General specifications

Material .....Frame : Aluminum, Impeller : Plastics  
 Life Expectancy .....Varies for each model (Survival rate: 90% at 60°C, rated voltage, and continuously run in a free air state)  
 Motor Protection System .....Current blocking function (with reverse polarity protection)  
 Dielectric Strength .....50/60 Hz, 500VAC, 1 minute (between lead conductor and frame)  
 Noise Measurement Method .....Measured at 1m from the air inlet  
 Operating Temperature Range .....Varies for each model (Non-condensing)  
 Lead Wire .....⊕red, ⊖black  
 Mass .....400g

### 38mm thick Specifications

Model No.	Rated Voltage (V)	Operating Voltage range (V)	Rated Current (A)	Rated Input (W)	Rated Speed (min <sup>-1</sup> )	Air Flow (m <sup>3</sup> /min) (CFM)	Static Pressure (Pa) (inchH <sub>2</sub> O)	Noise (dB [A])	Operating Temperature Range (°C)	Life Expectancy (h)
<b>9SG1212G102</b>	12	10.2~13.8	4.0	48.0	6,000	7.35 260	340 1.37	64	-10 ~ +70	40,000
<b>9SG1224G102</b>	24	20.4~27.6	2.0	48.0	6,000	7.35 260	340 1.37	64		
<b>9SG1248G102</b>	48	40.8~55.2	1.0	48.0	6,000	7.35 260	340 1.37	64		

### Air Flow and Static Pressure Characteristics

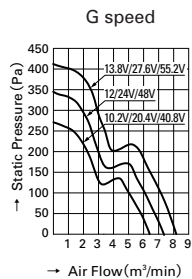

**9SG1212G102**  
**9SG1224G102**  
**9SG1248G102**

120mm

**Dimensions (unit : mm)**

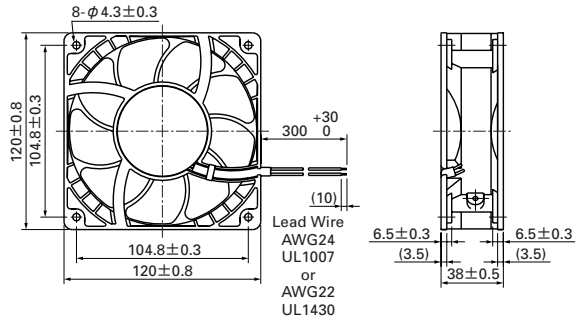

**Reference dimension of mounting holes and vent opening (unit : mm)**

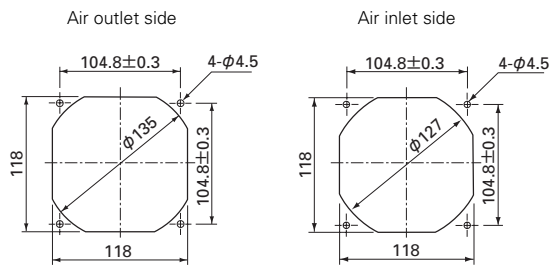

## DC Fan

□ **127mm**  
San Ace 127



### General specifications

Material ..... Frame, Impeller:Plastics  
 Life Expectancy .....Varies for each model (Survival rate: 90% at 60°C, rated voltage,and continuously run in a free air state)  
 Motor Protection System ....Current blocking function (with reverse polarity protection)  
 Dielectric Strength .....50/60 Hz, 500VAC, 1 minute (between lead conductor and frame)  
 Noise Measurement Method ...Measured at 1m from the air inlet  
 Operating Temperature Range .....Varies for each model (Non-condensing)  
 Lead Wire .....⊕red,⊖black  
 Mass .....350g

### 38mm thick Specifications

Model No.	Rated Voltage (V)	Operating Voltage Range (V)	Rated Current (A)	Rated Input (W)	Rated Speed (min <sup>-1</sup> )	Air Flow (m <sup>3</sup> /min) (CFM)	Static Pressure (Pa) (inchH <sub>2</sub> O)	Noise (dB [A])	Operating Temperature Range (°C)	Life Expectancy (h)
<b>109P1312S102(1021)</b>	12	10.2~13.8	1.3	15.6	3,300	4.2 148	117.6 0.472	47	-10 ~ +60	40,000
<b>109P1312H102(1021)</b>			0.82	9.84	2,950	3.8 134	98 0.394	45		
<b>109P1324S102(1021)</b>	24	20.4~27.6	0.55	13.2	3,300	4.2 148	117.6 0.472	47		
<b>109P1324H102(1021)</b>			0.41	9.84	2,950	3.8 134	98 0.394	45		
<b>109P1348S102(1021)</b>	48	40.8~55.2	0.3	14.4	3,300	4.2 148	117.6 0.472	47		
<b>109P1348H102(1021)</b>			0.2	9.6	2,950	3.8 134	98 0.394	45		

The numbers in ( ) represent ribless models.

### Air Flow and Static Pressure Characteristics

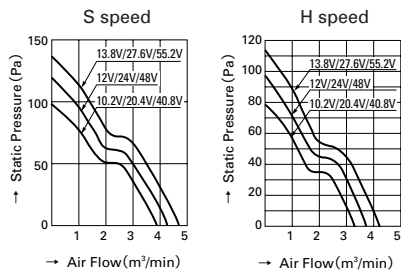

**109P1312S102 (1021)**    **109P1312H102 (1021)**  
**109P1324S102 (1021)**    **109P1324H102 (1021)**  
**109P1348S102 (1021)**    **109P1348H102 (1021)**

127mm

**Dimensions (unit : mm)**

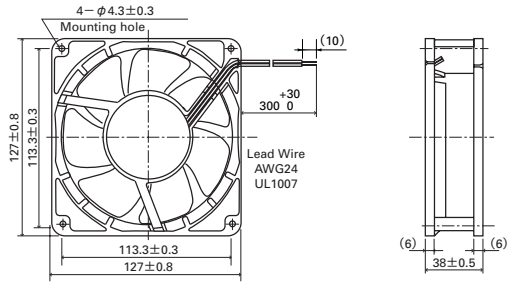

**Reference dimension of mounting holes and vent opening (unit : mm)**

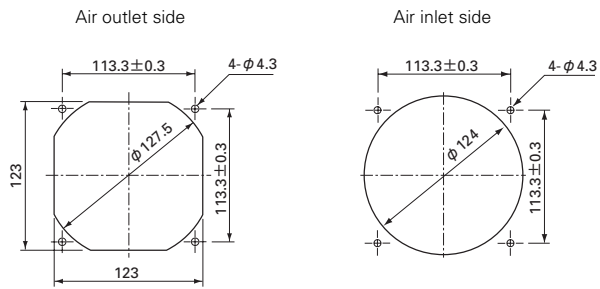

## DC Fan

**127mm**  
San Ace 127



### General specifications

- Material .....Frame, Aluminum, impeller:Plastics
- Life Expectancy .....Varies for each model (Survival rate: 90% at 60°C, rated voltage,and continuously run in a free air state)
- Motor Protection System .....Current blocking function (with reverse polarity protection)
- Dielectric Strength .....50/60 Hz, 500VAC, 1 minute (between lead conductor and frame)
- Noise Measurement Method .....Measured at 1m from the air inlet
- Operating Temperature Range .....Varies for each model (Non-condensing)
- Lead Wire .....⊕red,⊖black
- Mass .....400g

### 38mm thick Specifications

Model No.	Rated Voltage (V)	Operating Voltage Range (V)	Rated Current (A)	Rated Input (W)	Rated Speed (min <sup>-1</sup> )	Air Flow (m <sup>3</sup> /min) (CFM)	Static Pressure (Pa) (inchH <sub>2</sub> O)	Noise (dB [A])	Operating Temperature Range (°C)	Life Expectancy (h)
<b>109E1312A102</b>	12	10.2~13.8	1.4	16.8	3,850	4.81 170	155 0.622	52	-10 ~+70	40,000
<b>109E1312S102</b>			1.2	14.4	3,450	4.37 154	125 0.502	49		
<b>109E1324G102</b>	24	20.4~27.6	1.1	25.1	4,550	5.66 200	216 0.867	57	-10 ~+60	
<b>109E1324A102</b>			0.7	16.8	3,850	4.81 170	155 0.622	52	-10 ~+70	
<b>109E1324S102</b>			0.53	12.7	3,450	4.37 154	125 0.502	49	-10 ~+70	
<b>109E1348G102</b>	48	40.8~55.2	0.54	25.9	4,550	5.66 200	216 0.867	57	-10 ~+60	
<b>109E1348A102</b>			0.36	17.3	3,850	4.81 170	155 0.622	52	-10 ~+70	
<b>109E1348S102</b>			0.28	13.4	3,450	4.37 154	125 0.502	49	-10 ~+70	

### Air Flow and Static Pressure Characteristics

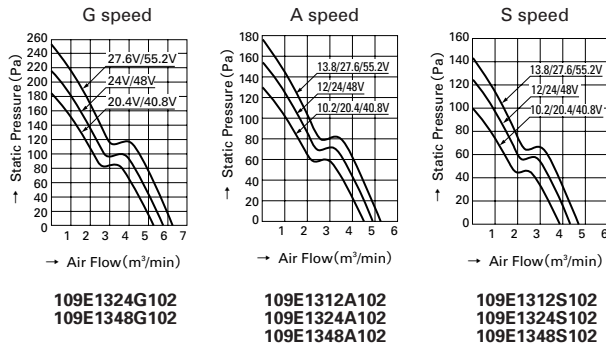

127mm

**Dimensions (unit : mm)**

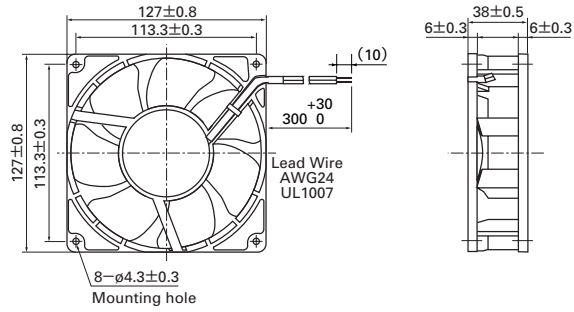

**Reference dimension of mounting holes and vent opening (unit : mm)**

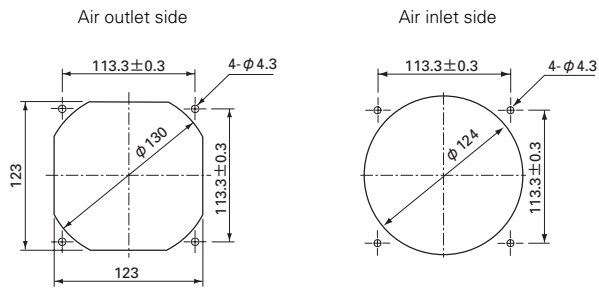

## DC Fan

□ **140mm**  
San Ace 140



### General specifications

- Material ..... Frame, Impeller:Plastics
- Life Expectancy .....Varies for each model (Survival rate: 90% at 60°C, rated voltage,and continuously run in a free air state)
- Motor Protection System .....Current blocking function (with reverse polarity protection)
- Dielectric Strength .....50/60 Hz, 500VAC, 1 minute (between lead conductor and frame)
- Noise Measurement Method .....Measured at 1m from the air inlet
- Operating Temperature Range .....Varies for each model (Non-condensing)
- Lead Wire .....H speed ⊕red, ⊖black  
M speed ⊕red, ⊖black or blue
- Mass .....450g

### 38mm thick Specifications

Model No.	Rated Voltage (V)	Operating Voltage Range (V)	Rated Current (A)	Rated Input (W)	Rated Speed (min <sup>-1</sup> )	Air Flow (m <sup>3</sup> /min) (CFM)	Static Pressure (Pa) (inchH <sub>2</sub> O)	Noise (dB [A])	Operating Temperature Range (°C)	Life Expectancy (h)
<b>109P1412H102</b>	12	10.2~13.8	0.73	8.76	2,600	4.5 159	94 0.378	46	-10~+70	40,000
<b>109P1412M102</b>			0.33	3.96	1,900	3.3 117	52 0.209	38		
<b>109P1424H102</b>	24	20.4~27.6	0.37	8.88	2,600	4.5 159	94 0.378	46		
<b>109P1424M102</b>			0.16	3.84	1,900	3.3 117	52 0.209	38		
<b>109P1448H102</b>	48	40.8~55.2	0.2	9.6	2,600	4.5 159	94 0.378	46		
<b>109P1448M102</b>			0.09	4.32	1,900	3.3 117	52 0.209	38		

### Air Flow and Static Pressure Characteristics

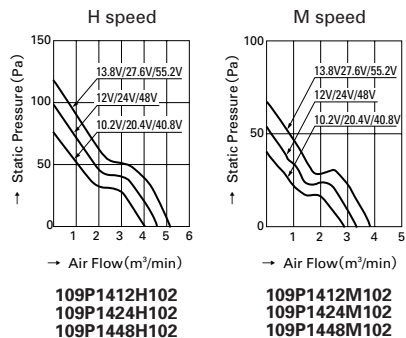

140mm



### Dimensions (unit : mm)

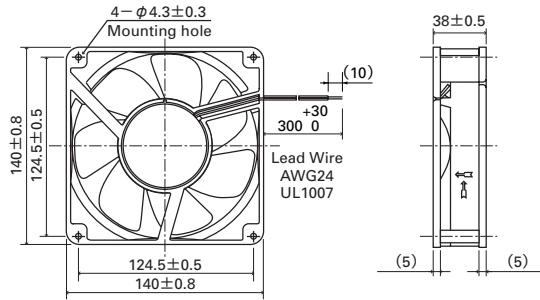

### Reference dimension of mounting holes and vent opening (unit : mm)

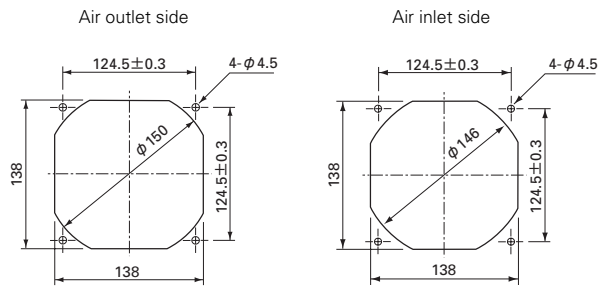

## DC Fan

□ **150mm**  
San Ace 150



### "San Ace 150" GV Type

#### General specifications

- Material .....Frame, Impeller:Plastics
- Life Expectancy .....Varies for each model (Survival rate: 90% at 60°C, rated voltage,and continuously run in a free air state)
- Motor Protection System ....Current blocking function (with reverse polarity protection)
- Dielectric Strength .....50/60 Hz, 500VAC, 1 minute (between lead conductor and frame)
- Noise Measurement Method ...Measured at 1m from the air inlet
- Operating Temperature Range .....Varies for each model (Non-condensing)
- Lead Wire .....⊕red,⊖black
- Mass .....450g

### 50mm thick Specifications

Model No.	Rated Voltage (V)	Operating Voltage Range (V)	Rated Current (A)	Rated Input (W)	Rated Speed (min <sup>-1</sup> )	Air Flow (m <sup>3</sup> /min) (CFM)	Static Pressure (Pa) (inchH <sub>2</sub> O)	Noise (dB [A])	Operating Temperature Range (°C)	Life Expectancy (h)
<b>9GV1512H502(5021)</b>	12	10.2~13.8	2.9	34.8	3,900	8.54 300	210 0.84	61	-10~+70	40,000
<b>9GV1512M502(5021)</b>			1.2	14.4	3,000	6.35 224	132 0.53	53		

The numbers in ( ) represent ribless models.

#### Air Flow and Static Pressure Characteristics

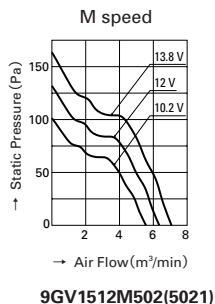
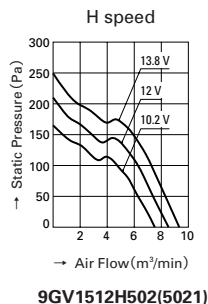

150mm

**Dimensions (unit : mm)**

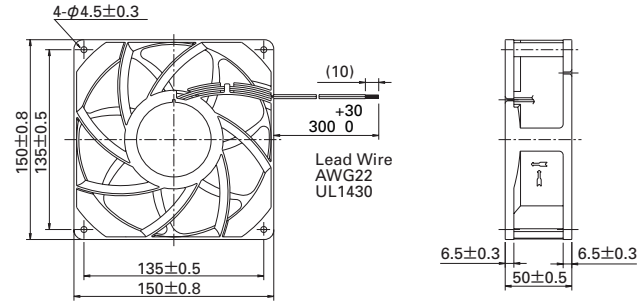

**Reference dimension of mounting holes and vent opening (unit : mm)**

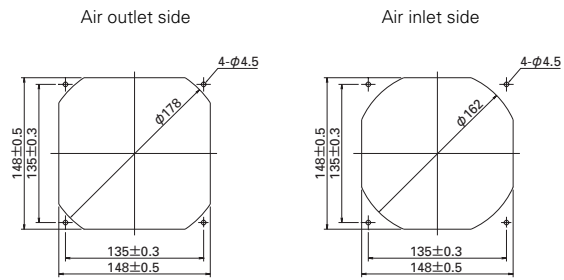



**Dimensions (unit : mm)**

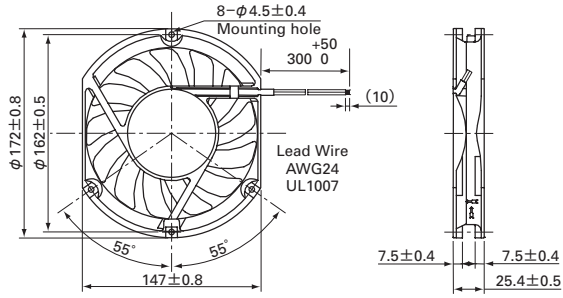

**Reference dimension of mounting holes and vent opening (unit : mm)**

Air inlet side · Air outlet side

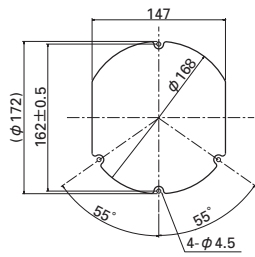

## DC Fan

Ø **172mm**  
San Ace 172



"San Ace 172" GV type



### General specifications

Material .....Frame : Aluminum , Impeller : Plastics  
 Life Expectancy .....Varies for each model (Survival rate: 90% at 60°C,  
 rated voltage, and continuously run in a free air state)  
 Motor Protection System ....Current blocking function (with reverse polarity protection)  
 Dielectric Strength .....50/60 Hz, 500VAC, 1 minute (between lead conductor and frame)  
 Noise Measurement Method ..Measured at 1m from the air inlet  
 Operating Temperature Range .....Varies for each model (Non-condensing)  
 Lead Wire .....⊕red, ⊖black  
 Mass .....800g

## 51 mm thick (Sidecut type) Specifications

Model No.	Rated Voltage (V)	Operating Voltage range (V)	Rated Current (A)	Rated Input (W)	Rated Speed (min <sup>-1</sup> )	Air Flow (m <sup>3</sup> /min) (CFM)	Static Pressure (Pa) (inchH <sub>2</sub> O)	Noise (dB [A])	Operating Temperature Range (°C)	Life Expectancy (h)
<b>9GV5724H502</b>	24	20.4~27.6	4.0	96	6,300	11.32 400	690 2.530	74	-10 ~ +70	40,000
<b>9GV5748H502</b>	48	40.8~55.2	2.0	96						

### Air Flow and Static Pressure Characteristics

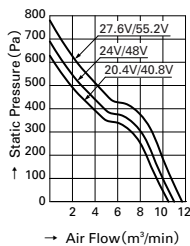

**9GV5724H502**  
**9GV5748H502**

**Dimensions (unit : mm)**

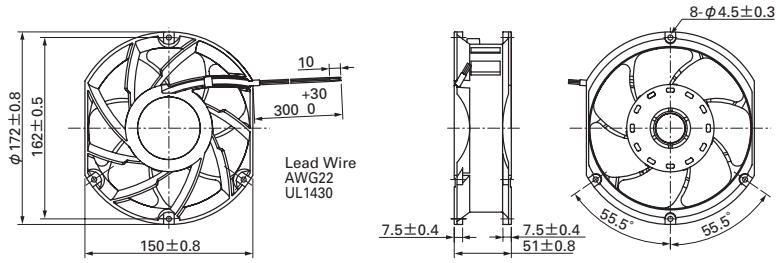

**Reference dimension of mounting holes and vent opening (unit : mm)**

Air inlet side · Air outlet side

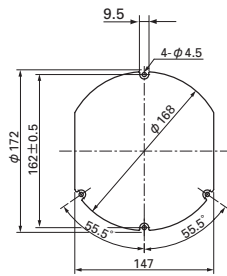





**Dimensions (unit : mm)**

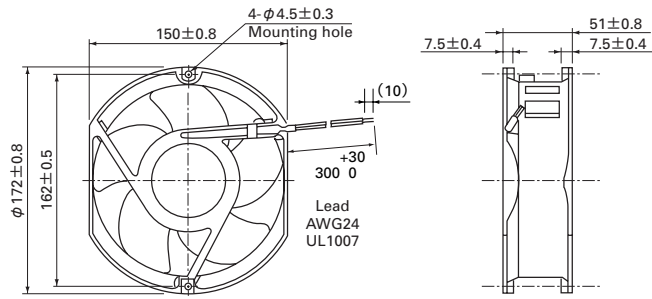

**Reference dimension of mounting holes and vent opening (unit : mm)**

Air inlet side · Air outlet side

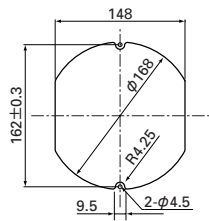



**Dimensions (unit : mm)**

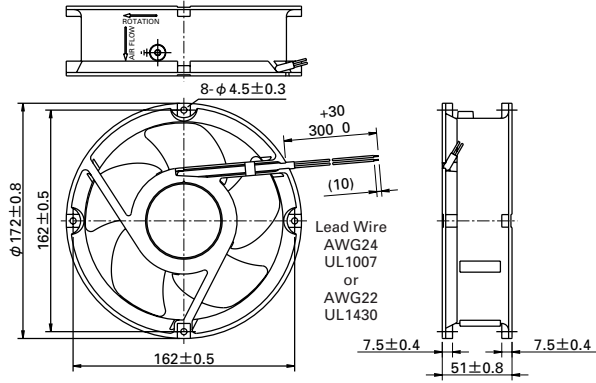

**Reference dimension of mounting holes and vent opening (unit : mm)**

Air inlet side · Air outlet side

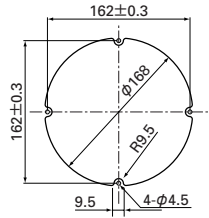

## DC Fan

∅ **200mm**  
San Ace 200



### General specifications

Material ..... Frame:Aluminum, Impeller:Plastics  
 Life Expectancy .....Varies for each model (Survival rate: 90% at 60°C, rated voltage,and continuously run in a free air state)  
 Motor Protection System .....Current blocking function (with reverse polarity protection)  
 Dielectric Strength .....50/60 Hz, 500VAC, 1 minute (between lead conductor and frame)  
 Noise Measurement Method .....Measured at 1m from the air inlet  
 Operating Temperature Range .....Varies for each model (Non-condensing)  
 Lead Wire .....⊕red, ⊖black, (Control) brown  
 Mass .....1800g

### 70mm thick Specifications

Model No.	Rated Voltage (V)	Operating Voltage Range (V)	Rated Current (A)	Rated Input (W)	Rated Speed (min <sup>-1</sup> )	Air Flow (m <sup>3</sup> /min) (CFM)	Static Pressure (Pa) (inchH <sub>2</sub> O)	Noise (dB [A])	Operating Temperature Range (°C)	Life Expectancy (h)
<b>109E2024H002</b>	24	20.4~27.6	1.0	24	2,600	8.2 289.5	192 0.771	51	-10 ~ +70	40,000
<b>109E2024S002</b>		21.6~26.4	1.9	45.6	3,200	10.45 369	287.1 1.153	57		
<b>109E2024MH002</b>		20.4~27.6	1.0	24	2,600	8.2 289.5	192 0.771	51		
			0.63	15.12	2,100	6.7 236.6	115.4 0.463	45		
<b>109E2024AS002</b>		21.6~26.4	1.9	45.6	3,200	10.45 369	287.1 1.153	57		
			1.4	33.6	2,800	9 317.8	217.5 0.873	54		

The MH speed and AS speed are two speeds.

### Air Flow and Static Pressure Characteristics

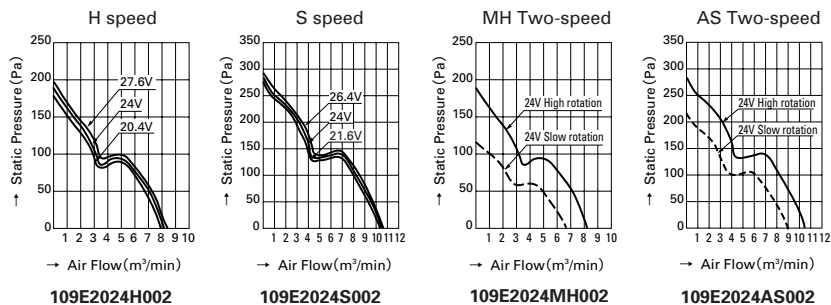

**Dimensions (unit : mm)**

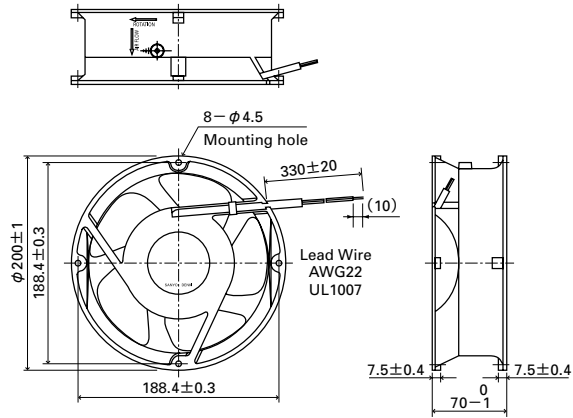

**Reference dimension of mounting holes and vent opening (unit : mm)**

Air inlet side · Air outlet side

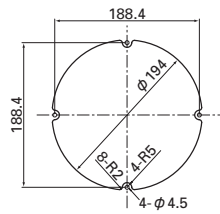

**Signal connection type**

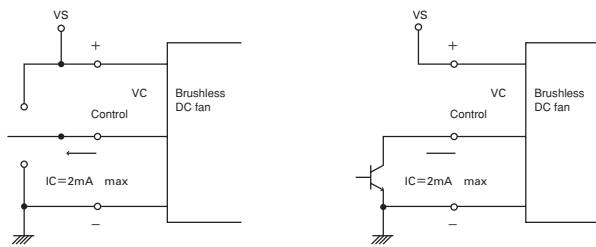

## DC Fan

∅ **200mm**  
San Ace 200

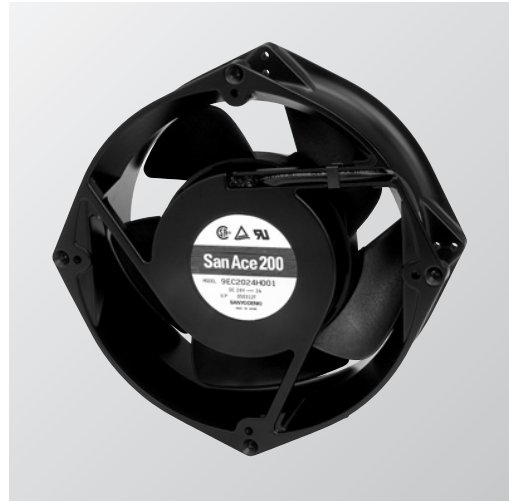

### General specifications

Material .....Frame:Aluminum, Impeller:Plastics  
 Life Expectancy .....Varies for each model (Survival rate: 90% at 60°C, rated voltage, and continuously run in a free air state)  
 Motor Protection System ....Current blocking function (with reverse polarity protection)  
 Dielectric Strength .....50/60 Hz, 500VAC, 1 minute (between lead conductor and frame)  
 Noise Measurement Method ...Measured at 1m from the air inlet  
 Operating Temperature Range .....Varies for each model (Non-condensing)  
 Lead Wire .....⊕red, ⊖black  
 Mass .....1800g

### 70mm thick Specifications

Model No.	Rated Voltage (V)	Operating Voltage Range (V)	Rated Current (A)	Rated Input (W)	Rated Speed (min <sup>-1</sup> )	Air Flow (m <sup>3</sup> /min) (CFM)	Static Pressure (Pa) (inchH <sub>2</sub> O)	Noise (dB [A])	Operating Temperature Range (°C)	Life Expectancy (h)
<b>9EC2024H002</b>	24	20.4~26.4	2.0	48.0	3,600	11.0 388	360 1.446	60	-10 ~ +60	40,000
<b>9EC2048A002</b>	48	43 ~51	2.2	105.6	4,800	14.7 519	640 2.570	68		
<b>9EC2048H002</b>		40.8~52.8	1.2	57.6	3,600	11.0 388	360 1.446	60		

### Air Flow and Static Pressure Characteristics

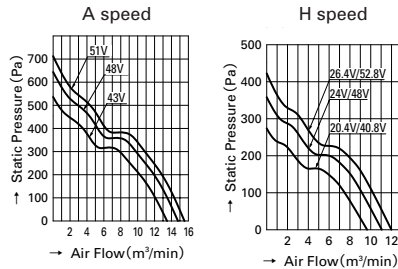

9EC2048A002

9EC2024H002  
9EC2048H002

**Dimensions (unit : mm)**

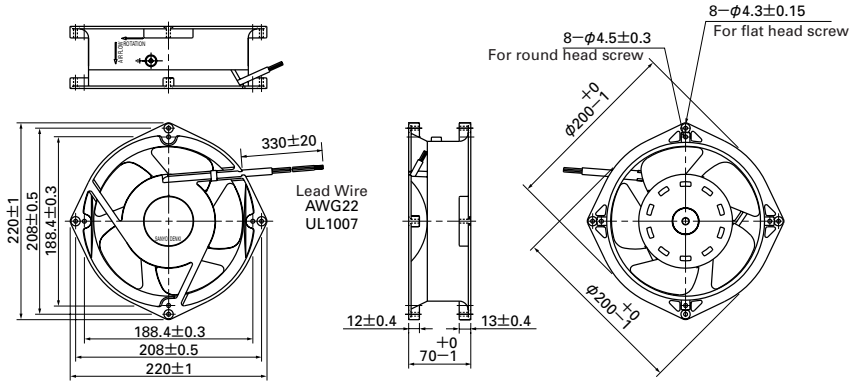

**Reference dimension of mounting holes and vent opening (unit : mm)**

Air inlet side · Air outlet side

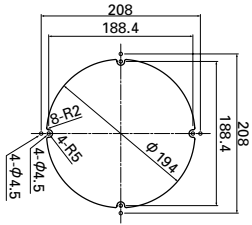

# DC Fan

## 60mm San Cooler 60



### General specifications

- Material ..... Frame, Impeller:Plastics
- Life Expectancy .....Varies for each model (Survival rate: 90% at 60°C, rated voltage,and continuously run in a free air state)
- Motor Protection System .....Current blocking function (with reverse polarity protection)
- Dielectric Strength .....50/60 Hz, 500VAC, 1 minute (between lead conductor and frame)
- Noise Measurement Method .....Measured at 1m from the air inlet
- Operating Temperature Range .....Varies for each model (Non-condensing)
- Lead Wire .....G,S,H,F speeds ⊕red,⊖black  
M speed ⊕red,⊖black or blue
- Mass .....80g

### 25mm thick Specifications

Model No.	Rated Voltage (V)	Operating Voltage Range (V)	Rated Current (A)	Rated Input (W)	Rated Speed (min <sup>-1</sup> )	Air Flow (m <sup>3</sup> /min) (CFM)	Static Pressure (Pa) (inchH <sub>2</sub> O)	Noise (dB [A])	Operating Temperature Range (°C)	Life Expectancy (h)
<b>9A0612G402(4021)</b>	12	6~13.2	0.24	2.88	5,600	0.78 27.6	87.3 0.351	39	-10 ~+60	30,000
<b>9A0612S402(4021)</b>			0.17	2.04	4,600	0.65 23.0	56.8 0.228	33		
<b>9A0612H402(4021)</b>			0.09	1.32	3,800	0.44 15.5	29.4 0.118	24		
<b>9A0612F402(4021)</b>										
<b>9A0612M402(4021)</b>										
<b>9A0624G402(4021)</b>	24	12~27.6	0.13	3.12	5,600	0.78 27.6	87.3 0.351	39	-10 ~+60	30,000
<b>9A0624S402(4021)</b>			0.08	1.92	4,600	0.65 23.0	56.8 0.228	33		
<b>9A0624H402(4021)</b>			0.06	1.44	3,800	0.53 18.7	40.2 0.161	28		
<b>9A0624F402(4021)</b>										
<b>9A0624M402(4021)</b>										
		14~27.6	0.04	0.96	2,600	0.36 12.7	19.6 0.079	20		

The numbers in ( ) represent ribless models.

### Air Flow and Static Pressure Characteristics

60mm

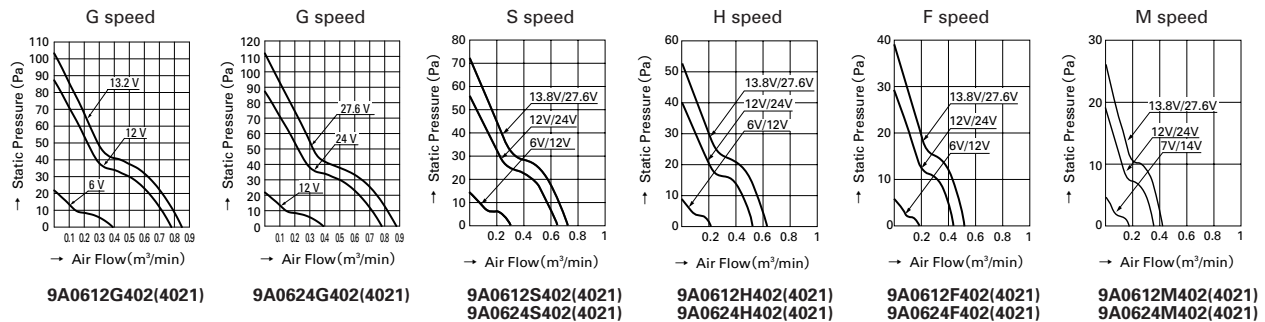

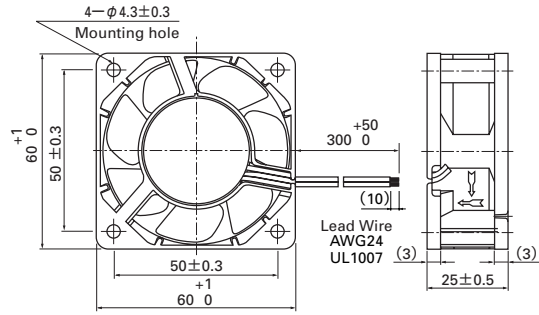

**Dimensions (unit : mm)****Reference dimension of mounting holes and vent opening (unit : mm)**

Air inlet side · Air outlet side

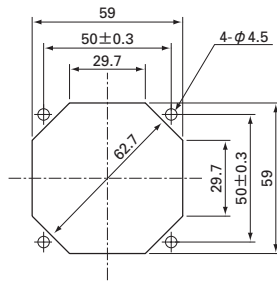
60mm

# DC Fan

## 80mm San Cooler 80



### General specifications

- Material ..... Frame, Impeller:Plastics
- Life Expectancy .....Varies for each model (Survival rate: 90% at 60°C, rated voltage,and continuously run in a free air state)
- Motor Protection System .....Current blocking function (with reverse polarity protection)
- Dielectric Strength .....50/60 Hz, 500VAC, 1 minute (between lead conductor and frame)
- Noise Measurement Method .....Measured at 1m from the air inlet
- Operating Temperature Range .....Varies for each model (Non-condensing)
- Lead Wire .....G,S,H,F speeds ⊕red,⊖black  
M speed ⊕red,⊖black or blue
- Mass .....90g

### 25mm thick Specifications

Model No.	Rated Voltage (V)	Operating Voltage Range (V)	Rated Current (A)	Rated Input (W)	Rated Speed (min <sup>-1</sup> )	Air Flow (m <sup>3</sup> /min) (CFM)	Static Pressure (Pa) (inchH <sub>2</sub> O)	Noise (dB [A])	Operating Temperature Range (°C)	Life Expectancy (h)
<b>9A0812G402(4021)</b>	12	6~13.2	0.38	4.56	4,500	1.5 53.0	80.3 0.323	40	-10 ~+60	30,000
<b>9A0812S402(4021)</b>			0.18	2.16	3,400	1.2 42.4	48 0.193	34		
<b>9A0812H402(4021)</b>			0.13	1.56	2,900	1.03 36.4	35.3 0.142	29		
<b>9A0812F402(4021)</b>		6~13.8	0.11	1.32	2,600	0.92 32.5	28.4 0.114	26		
<b>9A0812M402(4021)</b>			0.09	1.08	2,350	0.83 29.3	22.5 0.090	23		
<b>9A0812L402(4021)</b>			0.06	0.72	1,850	0.65 23.0	14.7 0.059	20		
<b>9A0824G402(4021)</b>	24	12~26.4	0.21	5.04	4,500	1.5 53.0	80.3 0.323	40	-10 ~+60	30,000
<b>9A0824S402(4021)</b>			0.1	2.4	3,400	1.2 42.4	48 0.193	34		
<b>9A0824H402(4021)</b>			0.07	1.68	2,900	1.03 36.4	35.3 0.142	29		
<b>9A0824F402(4021)</b>		12~27.6	0.06	1.44	2,600	0.92 32.5	28.4 0.114	26		
<b>9A0824M402(4021)</b>			0.05	1.2	2,350	0.83 29.3	22.5 0.090	23		
<b>9A0824L402(4021)</b>			0.04	0.96	1,850	0.65 23.0	14.7 0.059	20		

The numbers in ( ) represent ribless models.

### Air Flow and Static Pressure Characteristics

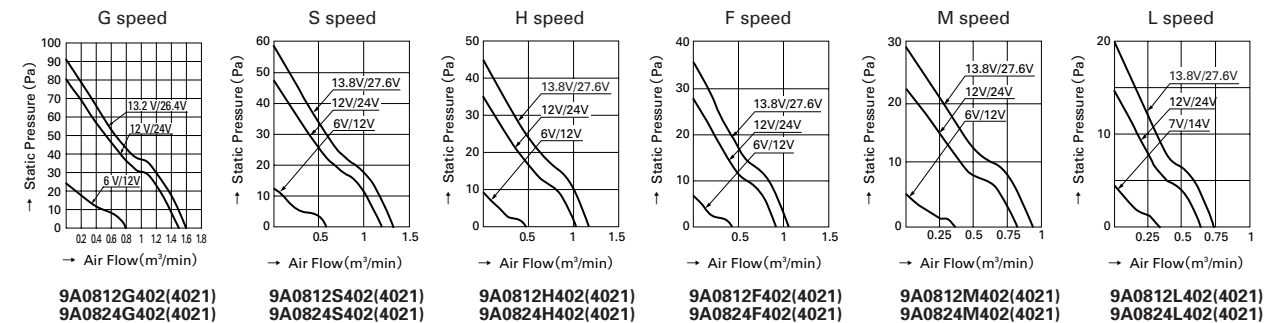

**9A0812G402(4021)**    **9A0812S402(4021)**    **9A0812H402(4021)**    **9A0812F402(4021)**    **9A0812M402(4021)**    **9A0812L402(4021)**  
**9A0824G402(4021)**    **9A0824S402(4021)**    **9A0824H402(4021)**    **9A0824F402(4021)**    **9A0824M402(4021)**    **9A0824L402(4021)**

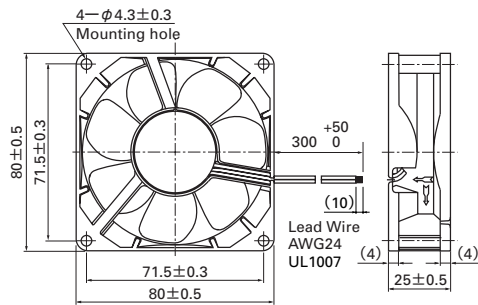
**Dimensions (unit : mm)****Reference dimension of mounting holes and vent opening (unit : mm)**

Air inlet side · Air outlet side

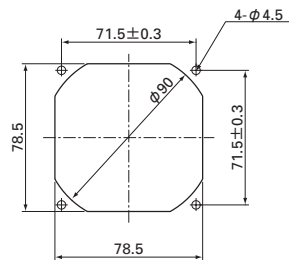
80mm

# DC Fan

## 92mm San Cooler 92



### General specifications

- Material ..... Frame, Impeller:Plastics
- Life Expectancy .....Varies for each model (Survival rate: 90% at 60°C, rated voltage,and continuously run in a free air state)
- Motor Protection System .....Current blocking function (with reverse polarity protection)
- Dielectric Strength .....50/60 Hz, 500VAC, 1 minute (between lead conductor and frame)
- Noise Measurement Method .....Measured at 1m from the air inlet
- Operating Temperature Range .....Varies for each model (Non-condensing)
- Lead Wire .....G,S,H,F speeds ⊕red,⊖black  
M speed ⊕red,⊖black or blue
- Mass .....100g

### 25mm thick Specifications

Model No.	Rated Voltage (V)	Operating Voltage Range (V)	Rated Current (A)	Rated Input (W)	Rated Speed (min <sup>-1</sup> )	Air Flow (m <sup>3</sup> /min) (CFM)		Static Pressure (Pa) (inchH <sub>2</sub> O)		Noise (dB [A])	Operating Temperature Range (°C)	Life Expectancy (h)
<b>9A0912G402(4021)</b>	12	6~13.8	0.39	4.68	3,900	1.76	62.1	66.5	0.267	43	-10 ~ +60	30,000
<b>9A0912S402(4021)</b>			0.27	3.24	3,550	1.66	58.6	56.1	0.225	39		
<b>9A0912H402(4021)</b>			0.21	2.52	3,150	1.45	51.2	44	0.177	33		
<b>9A0912F402(4021)</b>			0.14	1.68	2,650	1.24	43.8	32.2	0.129	30		
<b>9A0912M402(4021)</b>			0.12	1.44	2,250	1.04	36.7	22.6	0.091	27		
<b>9A0912L402(4021)</b>			0.07	0.84	1,750	0.8	28.2	13.4	0.054	23		
<b>9A0924G402(4021)</b>	24	12~27.6	0.19	4.56	3,900	1.76	62.1	66.5	0.267	43	-10 ~ +60	30,000
<b>9A0924S402(4021)</b>			0.15	3.6	3,550	1.66	58.6	56.1	0.225	39		
<b>9A0924H402(4021)</b>			0.1	2.4	3,150	1.45	51.2	44	0.177	33		
<b>9A0924F402(4021)</b>			0.08	1.92	2,650	1.24	43.8	32.2	0.129	30		
<b>9A0924M402(4021)</b>			0.05	1.2	2,250	1.04	36.7	22.6	0.091	27		
<b>9A0924L402(4021)</b>			0.04	0.96	1,750	0.8	28.2	13.4	0.054	23		

The numbers in ( ) represent ribless models.

### Air Flow and Static Pressure Characteristics

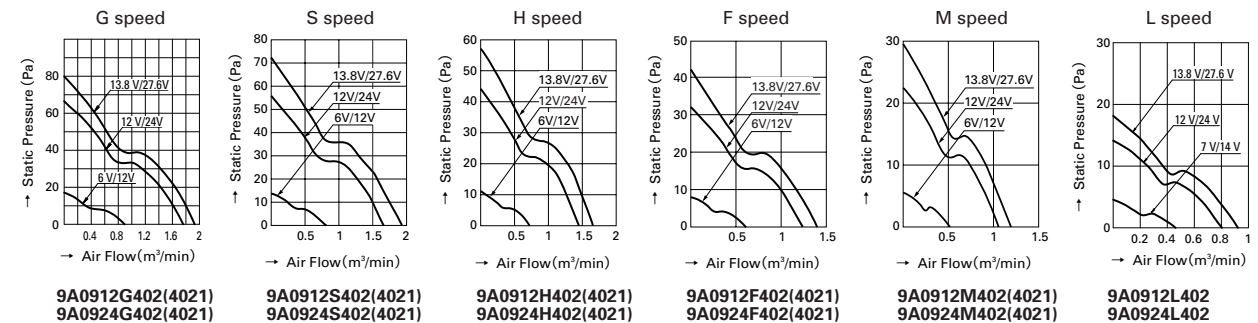

### Dimensions (unit : mm)

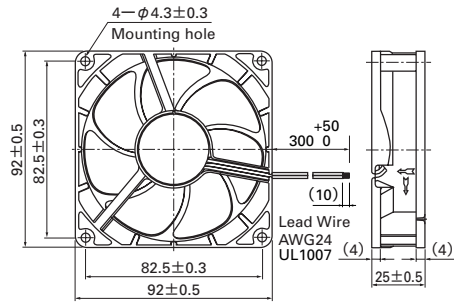

### Reference dimension of mounting holes and vent opening (unit : mm)

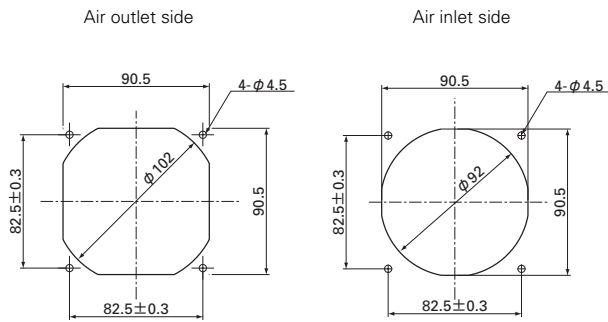

92mm



# COOLING SYSTEMS

## DC FAN

## Thermal Speed Controlled Fans

Thermal Speed Controlled Fans

### Domain diagram

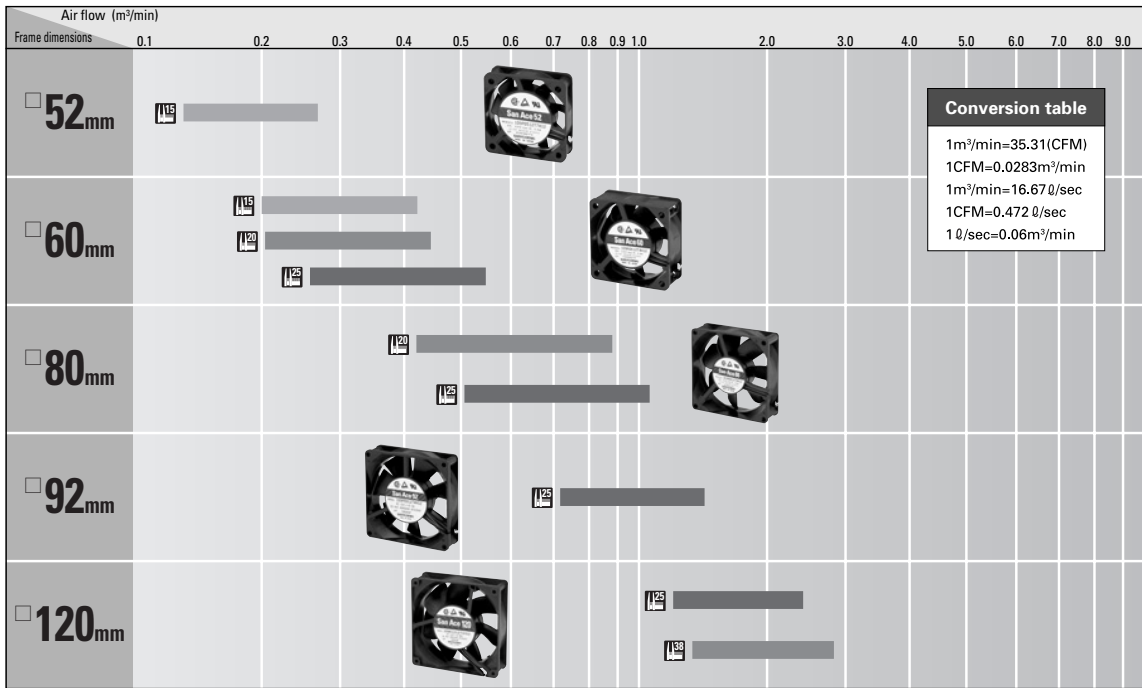

52mm  
60mm  
80mm  
92mm  
120mm

# Thermal speed controlled fans with an external or built-in thermistor

## External thermistor type

### 1. Overview

For thermal speed controlled fans with an external thermistor, just connect a specified thermistor (or a specified thermistor and a resistor) between the control wire and the negative wire indicated in Fig. 1, it will enable the fan speed to change automatically according to a predetermined temperature speed specification and according to temperature changes in an environment where the thermistor is equipped. (Please refer to Fig. 2)

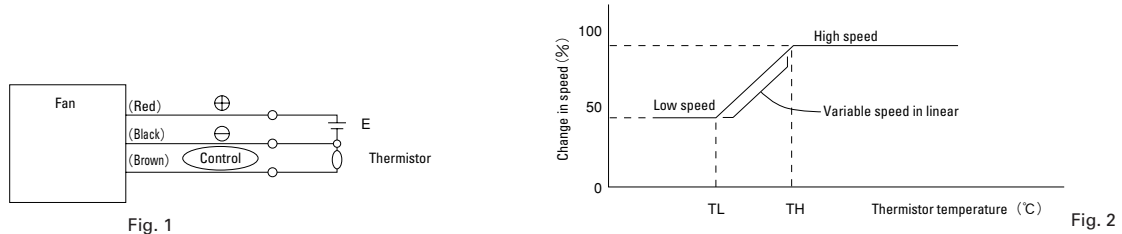

A thermistor can therefore be installed at an appropriate position inside your equipment to monitor the internal temperature changes due to changes in ambient temperature and heatup status (load status) of the equipment. Automatic monitoring can then specify low speed when the thermistor detects a temperature below TL, high speed when it detects a temperature above TH, and a speed according to the temperature when it detects a temperature between TL and TH. Thus, the fan motor detects its own operational status and determines the operating conditions. As a result, the thermal speed controlled fan with an external thermistor is designed that temperature changes according to the ambient temperature and operational status of the equipment are detected by the thermistor to control the fan's air flow (speed), and is near-ideal particularly in designing silent equipment. The fan motor thus meets the three requirements: silence, energy-saving, and long life.

### 2. Setting temperatures (TL and TH) in low and high speed

The standard products listed in this catalog are designed to run at a low speed at 28°C or below and run at a high speed at 35°C or more when a recommended thermistor is connected between the control wire and the negative wire. These temperatures (TL and TH) can be changed (as indicated in Table 1) by inserting a resistor in series with the thermistor.

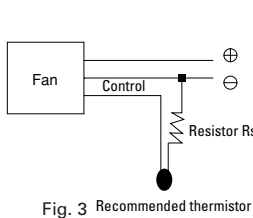

Resistance Rs (Ω)	Temperature setting (°C)	
	TL	TH
0	28	35
0.8K	31.5	40
1.5K	35	45
2.0K	38	50
2.4K	40.5	55
2.75K	43	60

\* For the resistor Rs, use a resistor rated at no less than 1/8W.  
\* For the thermistor, use a 159-682-86\*\* which are manufactured

### 3. If you wish to obtain low or high speed in a process of testing by using a larger equipment regardless of the thermistor temperature:

- Low speed : Instead of the thermistor, connect a 10 KΩ resistor between the control wire and the negative wire.
- High speed : Connect the control wire directly to the negative wire.

### 4. Connecting the fan to the thermistor

Sanyo Denki recommends to use connectors, including the power lead of the fan. Example of Typical connections : place a thermistor on the printed circuit board and connect the fan's power lead and control lead to the circuit pattern by means of connectors.

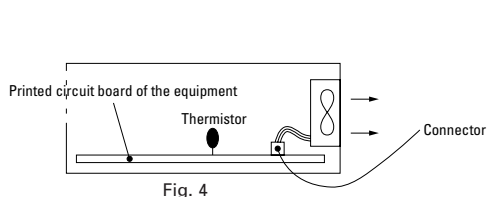

Manufacturer	Model (3-pole)
Japan Solderless Terminals	XHP-3,SMR-3V-N
Japan Aviation Electronics Industry	IL-G-3S-S3C2-SA
Japan AMP	171822-3
Molex Japan	5102-3

### 5. Typical applications of thermal speed controlled fans with an external thermistor

Here are typical applications of a thermal speed controlled fan with a power supply where two 109P1212H402 fans are used (Fig. 5).

- (1) The fan selected was a 109P1212T4H12 thermal speed controlled fan having a performance equal to that of conventional fans at high speed.
- (2) The relationship between the temperatures of important components and those of the cooling fin can be measured with varied loads on the equipment and varied air flows of the fan. Since a correlation was determined, the thermistor can then be placed on the cooling fin, one of the important components.
- (3) Next, in view of the thermal design conditions of the equipment, the fan is set to high speed at an ambient temperature of 30°C and an equipment load of 100%.



- (4) At an ambient temperature of 30°C and an equipment load of 100%, the temperature of the cooling fin was 48°C and the surface temperature of the thermistor placed on the cooling fin was 45°C when the fan was running at high speed. It was therefore decided to add a 1.5 KΩ resistor in series with the thermistor according to Table 1. In this case, the thermistor temperature is 35°C and the fan runs at low (see Table 1 and Fig. 6).

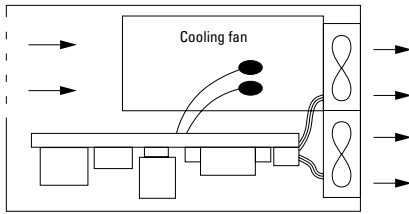
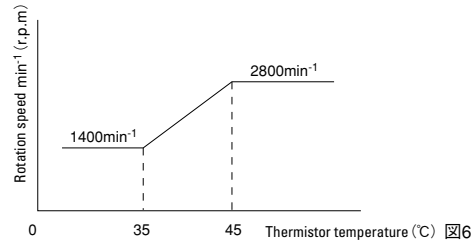

Fig. 5



- (5) Test results as installed on equipment: The thermal speed controlled fan displayed its full effect, thus being greatly advantageous in noise reduction. The ambient temperature during the test was 29°C.

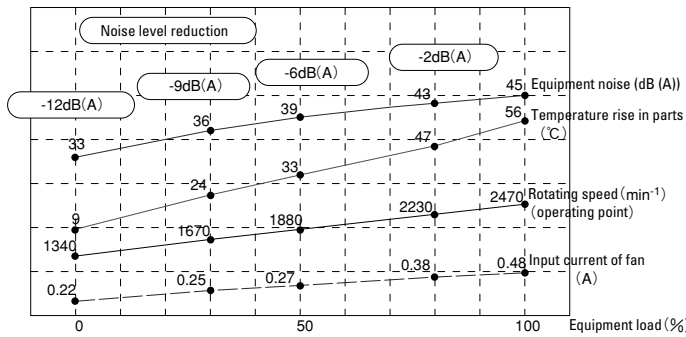

Fig. 7

- \* An ideal drop in the fan noise level was achieved according to the equipment load. When the equipment load was 0, the noise was 12dB (A) lower than in the case of conventional models.
- \* The current consumption of the fan was 54% lower than in the case of conventional models when the equipment load was 0.
- \* The noise level is expected to decline further at lower ambient temperatures.

### built-in thermistor type

#### 1. Overview

Thermal speed controlled fans with a built-in thermistor are designed that the fan itself contains a thermistor as indicated in Fig. 8. As illustrated in Fig. 9, the temperature of the air flowing through the fan motor is detected and the fan's speed changes automatically according to changes in that temperature.

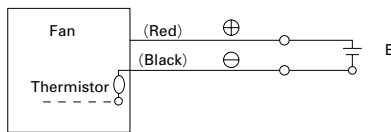

Fig. 8

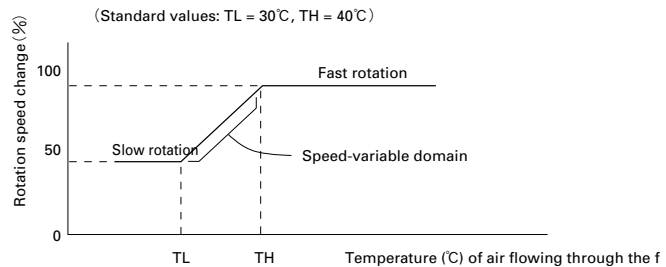
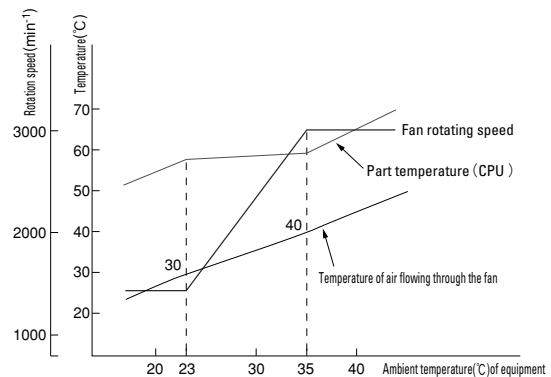
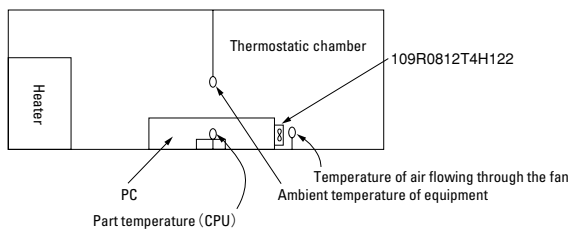

Fig. 9

#### 2. Typical applications of thermal speed controlled fans with a built-in thermistor

Fig. 11 indicates measurements taken when a 109R0812T4H122 fan is mounted on equipment (a PC) is tested in the state as illustrated in Fig. 10.



Thermal Speed Controlled Fans

# Thermal Speed Controlled Fan

52mm  
San Ace 52



Photo: externally-mounted thermistor

## General specifications

- Material .....Frame, Impeller:Plastics
- Life Expectancy .....Varies for each model (Survival rate: 90% at 60°C, rated voltage,and continuously run in a free air state)
- Motor Protection System ....Current blocking function (with reverse polarity protection)
- Dielectric Strength .....50/60 Hz, 500VAC, 1 minute (between lead conductor and frame)
- Noise Measurement Method ...Measured at 1m from the air inlet
- Operating Temperature Range .....Varies for each model (Non-condensing)
- Lead Wire .....⊕red, ⊖black, (Control) brown (Only for external thermistor type)
- Fail-safe .....The motor becomes high speed when the thermistor is unable to detect the temperature in cases of open circuit or short-circuit.
- Mass .....55g

## 15mm thick with an external thermistor Specifications

Model No.	Rated Voltage (V)	Operating Voltage Range (V)	Rated Current (A)	Rated Input (W)	Rated Speed (min <sup>-1</sup> )	Air Flow (m <sup>3</sup> /min) (CFM)	Static Pressure (Pa) (inchH.O)	Noise (dB [A])	Operating Temperature Range (°C)	Life Expectancy (h)
109P0512T7H12	12	10.2~13.8	0.13	1.56	4,600	0.255 9.0	31.9 0.128	27	-10 ~ +70	60,000
			0.09	1.08	2,300	0.13 4.6	8.8 0.035	17		

Notes:The top row gives characteristics shown when the thermistor temperature is 35°C, while the bottom row gives characteristics shown when the thermistor temperature is 28°C.

### Air Flow and Static Pressure Characteristics

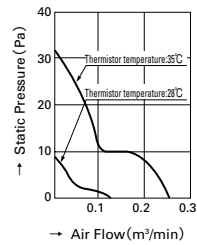

109P0512T7H12

### Characteristics of Thermistor-detected Temperature vs Speed

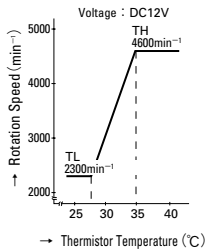

52mm

### Dimensions (unit : mm)

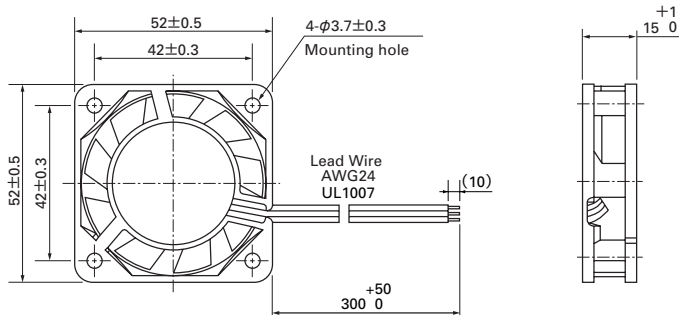

# 15mm thick with an external thermistor

## Specifications

Model No.	Rated Voltage (V)	Operating Voltage Range (V)	Rated Current (A)	Rated Input (W)	Rated Speed (min <sup>-1</sup> )	Air Flow (m <sup>3</sup> /min) (CFM)	Static Pressure (Pa) (inchH <sub>2</sub> O)	Noise (dB [A])	Operating Temperature Range (°C)	Life Expectancy (h)
109P0512T7H122	12	10.2~13.8	0.13	1.56	4,900	0.27 9.5	36.2 0.145	28	-10 ~ +70	60,000
			0.09	1.08	2,400	0.14 4.9	9.6 0.039	17		

Notes: The top row gives characteristics shown when the thermistor temperature is 35°C, while the bottom row gives characteristics shown when the thermistor temperature is 28°C.

Thermal Speed Controlled Fans

### Air Flow and Static Pressure Characteristics

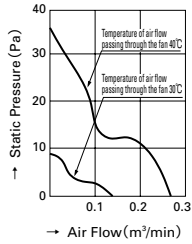

109P0512T7H122

### Typical characteristics of temperature of air flowing through the fan versus rotation speed

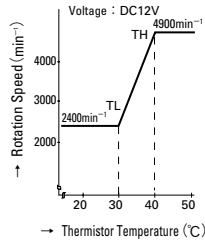

### Dimensions (unit : mm)

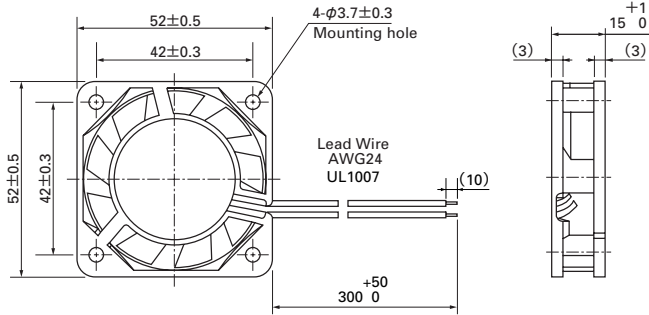

52mm

### Reference dimension of mounting holes and vent opening (unit : mm)

Air inlet side · Air outlet side

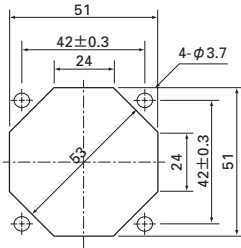

Thermal Speed  
Controlled Fans

# Thermal Speed Controlled Fan

## 60mm San Ace 60



Photo: externally-mounted thermistor

### General specifications

- Material .....Frame, Impeller:Plastics
- Life Expectancy .....Varies for each model (Survival rate: 90% at 60°C, rated voltage,and continuously run in a free air state)
- Motor Protection System ....Current blocking function (with reverse polarity protection)
- Dielectric Strength .....50/60 Hz, 500VAC, 1 minute (between lead conductor and frame)
- Noise Measurement Method ..Measured at 1m from the air inlet
- Operating Temperature Range ....Varies for each model (Non-condensing)
- Lead Wire .....⊕red,⊖black, (Control) brown (Only for external thermistor type)
- Fail-safe .....The motor becomes high speed when the thermistor is unable to detect the temperature in cases of open or short circuit etc.
- Mass .....60g(15mm thick) 90g(20mm thick) 25mm thick)

### 15mm thick with an external thermistor Specifications

Model No.	Rated Voltage (V)	Operating Voltage Range (V)	Rated Current (A)	Rated Input (W)	Rated Speed (min <sup>-1</sup> )	Air Flow (m <sup>3</sup> /min) (CFM)		Static Pressure (Pa) (inchH <sub>2</sub> O)		Noise (dB [A])	Operating Temperature Range (°C)	Life Expectancy (h)
109P0612T7H12	12	10.2~13.8	0.12	1.44	4,100	0.4	14.1	38.2	0.153	32	-10 ~+70	60,000
			0.08	0.96	2,050	0.2	7.1	9.3	0.037	18		

Notes:The top row gives characteristics shown when the thermistor temperature is 35°C, while the bottom row gives characteristics shown when the thermistor temperature is 28°C.

### 20mm thick with an external thermistor Specifications

Model No.	Rated Voltage (V)	Operating Voltage Range (V)	Rated Current (A)	Rated Input (W)	Rated Speed (min <sup>-1</sup> )	Air Flow (m <sup>3</sup> /min) (CFM)		Static Pressure (Pa) (inchH <sub>2</sub> O)		Noise (dB [A])	Operating Temperature Range (°C)	Life Expectancy (h)
109P0612T6H12	12	10.2~13.8	0.15	1.8	4,200	0.42	14.8	31.9	0.128	31	-10 ~+70	60,000
			0.1	1.2	2,100	0.21	7.4	8.8	0.035	21		

Notes:The top row gives characteristics shown when the thermistor temperature is 35°C, while the bottom row gives characteristics shown when the thermistor temperature is 28°C.

### 25mm thick with an external thermistor Specifications

Model No.	Rated Voltage (V)	Operating Voltage Range (V)	Rated Current (A)	Rated Input (W)	Rated Speed (min <sup>-1</sup> )	Air Flow (m <sup>3</sup> /min) (CFM)		Static Pressure (Pa) (inchH <sub>2</sub> O)		Noise (dB [A])	Operating Temperature Range (°C)	Life Expectancy (h)
109R0612T4H12(121)	12	10.2~13.8	0.13	1.56	3,800	0.53	18.7	40.2	0.161	28	-10 ~+60	60,000
			0.1	1.2	1,900	0.26	9.2	9.8	0.039	15		

The numbers in ( ) represent ribless models.  
Notes:The top row gives characteristics shown when the thermistor temperature is 35°C, while the bottom row gives characteristics shown when the thermistor temperature is 28°C.

### Air Flow and Static Pressure Characteristics

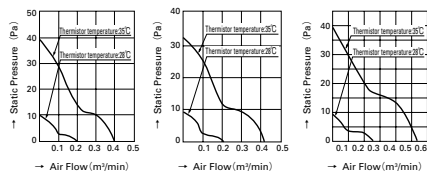

109P0612T7H12 109P0612T6H12 109R0612T4H12(121)

### Characteristics of Thermistor-detected Temperature vs Speed

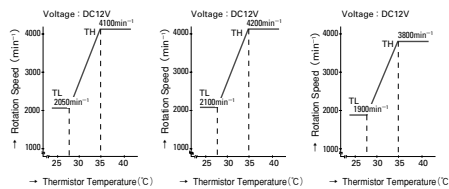

109P0612T7H12 109P0612T6H12 109R0612T4H12(121)

### Dimensions (unit : mm)

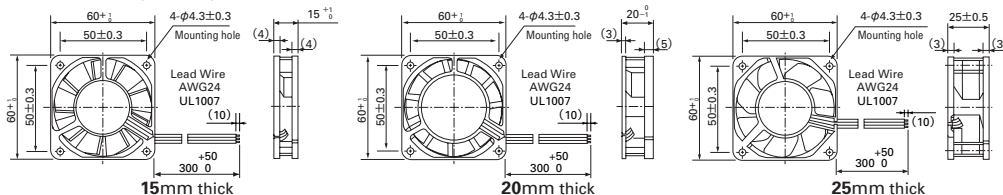

# 15mm thick with a built-in thermistor

## Specifications

Model No.	Rated Voltage (V)	Operating Voltage Range (V)	Rated Current (A)	Rated Input (W)	Rated Speed (min <sup>-1</sup> )	Air Flow (m <sup>3</sup> /min) (CFM)	Static Pressure (Pa) (inchH <sub>2</sub> O)	Noise (dB [A])	Operating Temperature Range (°C)	Life Expectancy (h)
109P0612T7H122	12	10.2~13.8	0.12	1.44	4,300	0.42 14.8	42.0 0.169	32	-10 ~ +70	60,000
			0.08	0.96	2,100	0.2 7.0	9.7 0.039	18		

Note 1: The top row gives characteristics shown when the temperature is 40°C, while the bottom row gives characteristics shown when the temperature is 30°C.  
 Note 2: The noise levels are calculated by converting measurements taken at 30cm to those measured at 1m.

# 20mm thick with a built-in thermistor

## Specifications

Model No.	Rated Voltage (V)	Operating Voltage Range (V)	Rated Current (A)	Rated Input (W)	Rated Speed (min <sup>-1</sup> )	Air Flow (m <sup>3</sup> /min) (CFM)	Static Pressure (Pa) (inchH <sub>2</sub> O)	Noise (dB [A])	Operating Temperature Range (°C)	Life Expectancy (h)
109P0612T6H122	12	10.2~13.8	0.15	1.8	4,400	0.44 15.5	35.0 0.141	33	-10 ~ +70	60,000
			0.1	1.2	2,150	0.22 7.8	9.2 0.037	21		

Note 1: The top row gives characteristics shown when the temperature is 40°C, while the bottom row gives characteristics shown when the temperature is 30°C.  
 Note 2: The noise levels are calculated by converting measurements taken at 30cm to those measured at 1m.

# 25mm thick with a built-in thermistor

## Specifications

Model No.	Rated Voltage (V)	Operating Voltage Range (V)	Rated Current (A)	Rated Input (W)	Rated Speed (min <sup>-1</sup> )	Air Flow (m <sup>3</sup> /min) (CFM)	Static Pressure (Pa) (inchH <sub>2</sub> O)	Noise (dB [A])	Operating Temperature Range (°C)	Life Expectancy (h)
109R0612T4H122(123)	12	10.2~13.8	0.13	1.56	3,950	0.55 19.4	41.8 0.168	28	-10 ~ +60	60,000
			0.1	1.2	1,950	0.27 9.5	10.3 0.041	15		

The numbers in ( ) represent ribless models.  
 Note 1: The top row gives characteristics shown when the temperature is 40°C, while the bottom row gives characteristics shown when the temperature is 30°C.  
 Note 2: The noise levels are calculated by converting measurements taken at 30cm to those measured at 1m.

### Air Flow and Static Pressure Characteristics

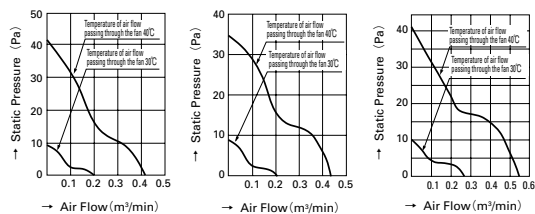

109P0612T7H122    109P0612T6H122    109R0612T4H122(123)

### Typical characteristics of temperature of air flowing through the fan versus rotation speed

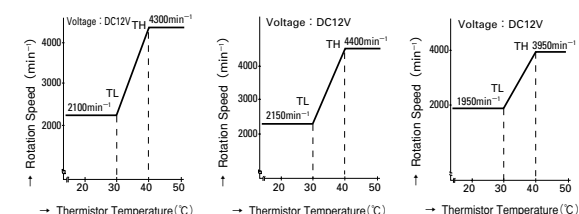

109P0612T7H122    109P0612T6H122    109R0612T4H122(123)

### Dimensions (unit: mm)

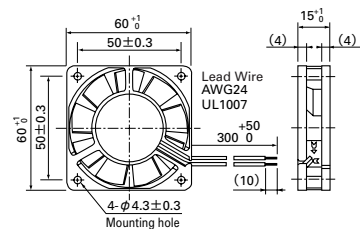

15mm thick

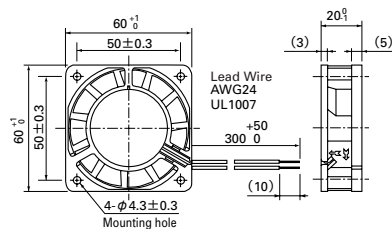

20mm thick

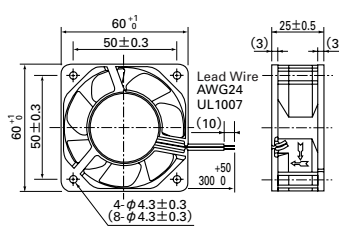

25mm thick

60mm

### Reference dimension of mounting holes and vent opening (unit: mm)

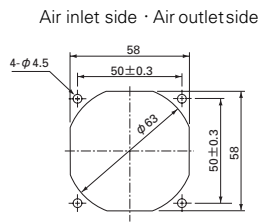

15mm thick  
20mm thick

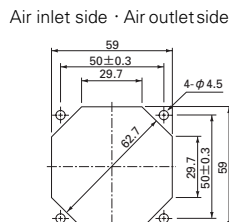

25mm thick

Thermal Speed  
Controlled Fans

# Thermal Speed Controlled Fan

80mm  
San Ace 80



Photo: externally-mounted thermistor

## General specifications

- Material .....Frame, Impeller:Plastics
- Life Expectancy .....Varies for each model (Survival rate: 90% at 60°C, rated voltage,and continuously run in a free air state)
- Motor Protection System .....Current blocking function (with reverse polarity protection)
- Dielectric Strength .....50/60 Hz, 500VAC, 1 minute (between lead conductor and frame)
- Noise Measurement Method .....Measured at 1m from the air inlet
- Operating Temperature Range .....Varies for each model (Non-condensing)
- Lead Wire .....⊕red, ⊖black, (Control) brown (Only for external thermistor type)
- Fail-safe .....The motor becomes high speed when the thermistor is unable to detect the temperature in cases of open or short circuit etc.
- Mass .....100g (20mm thick) 110g (25mm thick)

## 20mm thick with an external thermistor Specifications

Model No.	Rated Voltage (V)	Operating Voltage Range (V)	Rated Current (A)	Rated Input (W)	Rated Speed (min <sup>-1</sup> )	Air Flow (m <sup>3</sup> /min) (CFM)	Static Pressure (Pa) (inchH <sub>2</sub> O)	Noise (dB [A])	Operating Temperature Range (°C)	Life Expectancy (h)
109P0812T6H12	12	10.2~13.8	0.18	2.16	2,900	0.84 29.7	29.4 0.118	31	-10 ~ +60	60,000
			0.1	1.2	1,450	0.42 14.8	7.4 0.030	18		

Notes: The top row gives characteristics shown when the thermistor temperature is 35°C, while the bottom row gives characteristics shown when the thermistor temperature is 28°C.

## 25mm thick with an external thermistor Specifications

Model No.	Rated Voltage (V)	Operating Voltage Range (V)	Rated Current (A)	Rated Input (W)	Rated Speed (min <sup>-1</sup> )	Air Flow (m <sup>3</sup> /min) (CFM)	Static Pressure (Pa) (inchH <sub>2</sub> O)	Noise (dB [A])	Operating Temperature Range (°C)	Life Expectancy (h)
109R0812T4H12(121)	12	10.2~13.8	0.14	1.68	2,900	1.03 36.4	35.3 0.142	29	-10 ~ +60	60,000
			0.09	1.08	1,450	0.51 18.0	8.8 0.035	14		

The numbers in ( ) represent ribless models.  
Notes: The top row gives characteristics shown when the thermistor temperature is 35°C, while the bottom row gives characteristics shown when the thermistor temperature is 28°C.

## Air Flow and Static Pressure Characteristics

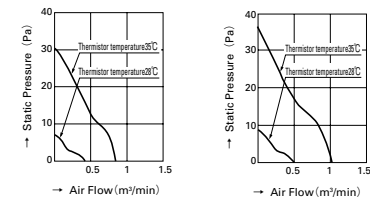

109P0812T6H12

109R0812T4H12(121)

## Characteristics of Thermistor-detected Temperature vs Speed

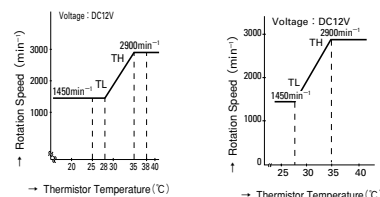

109P0812T6H12

109R0812T4H12(121)

## Dimensions (unit : mm)

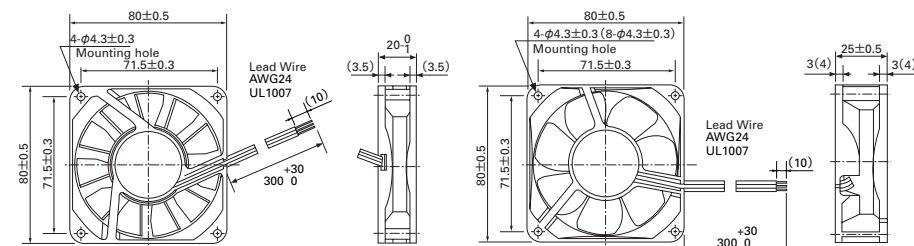

20mm thick

25mm thick

# 20mm thick with a built-in thermistor

## Specifications

Model No.	Rated Voltage (V)	Operating Voltage Range (V)	Rated Current (A)	Rated Input (W)	Rated Speed (min <sup>-1</sup> )	Air Flow (m <sup>3</sup> /min) (CFM)	Static Pressure (Pa) (inchH <sub>2</sub> O)	Noise (dB [A])	Operating Temperature Range (°C)	Life Expectancy (h)
<b>109P0812T6H122</b>	12	10.2~13.8	0.18	2.16	3,050	0.88 31.0	32.5 0.131	32	-10 ~ +60	60,000
			0.1	1.2	1,450	0.42 14.8	7.4 0.030	20		

Note 1: The top row gives characteristics shown when the temperature is 40°C, while the bottom row gives characteristics shown when the temperature is 30°C.  
 Note 2: The noise levels are calculated by converting measurements taken at 30cm to those measured at 1m.

# 25mm thick with a built-in thermistor

## Specifications

Model No.	Rated Voltage (V)	Operating Voltage Range (V)	Rated Current (A)	Rated Input (W)	Rated Speed (min <sup>-1</sup> )	Air Flow (m <sup>3</sup> /min) (CFM)	Static Pressure (Pa) (inchH <sub>2</sub> O)	Noise (dB [A])	Operating Temperature Range (°C)	Life Expectancy (h)
<b>109R0812T4H122(123)</b>	12	10.2~13.8	0.14	1.68	3,000	1.07 37.8	37.7 0.151	29	-10 ~ +60	60,000
			0.09	1.08	1,450	0.51 18.0	8.8 0.035	14		

The numbers in ( ) represent ribless models.  
 Note 1: The top row gives characteristics shown when the temperature is 40°C, while the bottom row gives characteristics shown when the temperature is 30°C.  
 Note 2: The noise levels are calculated by converting measurements taken at 30cm to those measured at 1m.

Thermal Speed Controlled Fans

### Air Flow and Static Pressure Characteristics

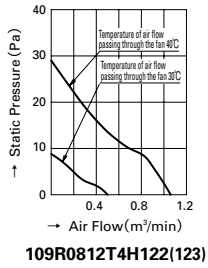
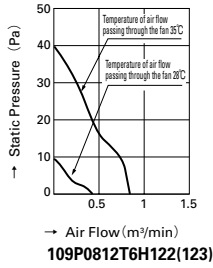

### Typical characteristics of temperature of air flowing through the fan versus rotation speed

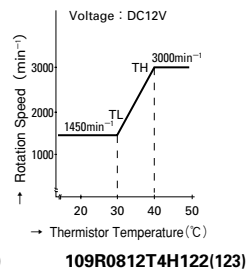
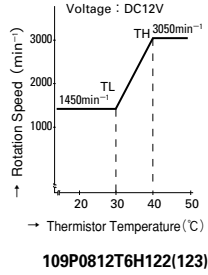

### Dimensions (unit : mm)

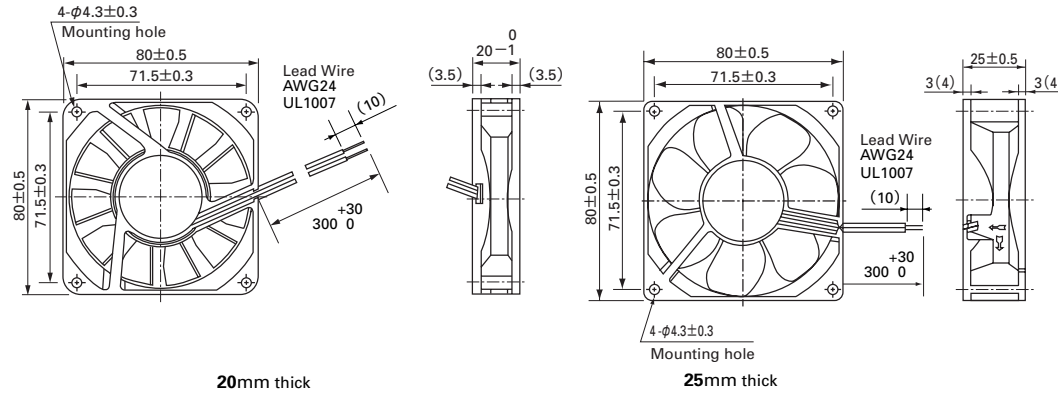

### Reference dimension of mounting holes and vent opening (unit : mm)

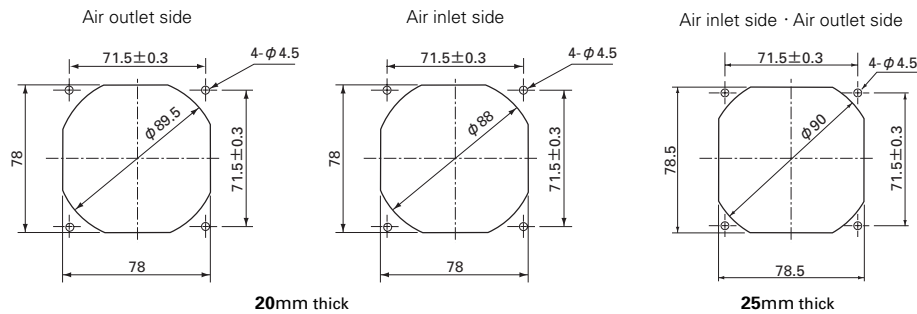

80mm

Thermal Speed Controlled Fans

# Thermal Speed Controlled Fan

92mm  
San Ace 92



Photo: externally-mounted thermistor

## General specifications

- Material ..... Frame, Impeller:Plastics
- Life Expectancy .....Varies for each model (Survival rate: 90% at 60°C, rated voltage,and continuously run in a free air state)
- Motor Protection System ....Current blocking function (with reverse polarity protection)
- Dielectric Strength .....50/60 Hz, 500VAC, 1 minute (between lead conductor and frame)
- Noise Measurement Method ..Measured at 1m from the air inlet
- Operating Temperature Range .....Varies for each model (Non-condensing)
- Lead Wire .....⊕red, ⊖black, (Control) brown (Only for external thermistor type)
- Fail-safe .....The motor becomes high speed when the thermistor is unable to detect the temperature in cases of open or short circuit etc.
- Mass .....150g

## 25mm thick with an external thermistor Specifications

Model No.	Rated Voltage (V)	Operating Voltage Range (V)	Rated Current (A)	Rated Input (W)	Rated Speed (min <sup>-1</sup> )	Air Flow (m <sup>3</sup> /min) (CFM)	Static Pressure (Pa) (inchH.O)	Noise (dB [A])	Operating Temperature Range (°C)	Life Expectancy (h)
109P0912T4H12(121)	12	10.2~13.8	0.2	2.4	2,850	1.45 51.2	45.1 0.181	33	-10 ~ +60	40,000
			0.1	1.2	1,400	0.71 25.0	11.3 0.045	18		

The numbers in ( ) represent ribless models.

Notes: The top row gives characteristics shown when the thermistor temperature is 35°C, while the bottom row gives characteristics shown when the thermistor temperature is 28°C.

### Air Flow and Static Pressure Characteristics

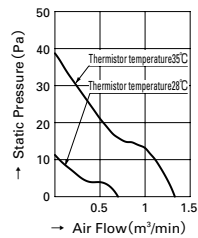

109P0912T4H12(121)

### Characteristics of Thermistor-detected Temperature vs Speed

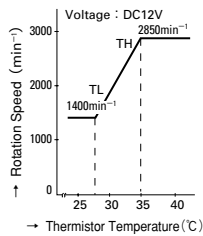

109P0912T4H12(121)

92mm

### Dimensions (unit : mm)

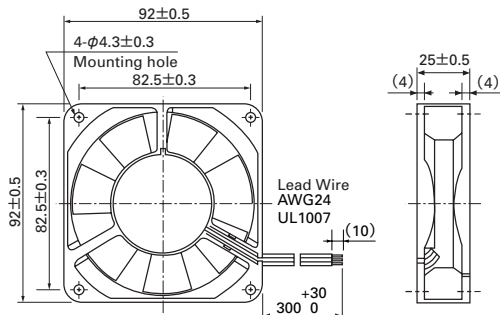



# 25mm thick with a built-in thermistor

## Specifications

Model No.	Rated Voltage (V)	Operating Voltage Range (V)	Rated Current (A)	Rated Input (W)	Rated Speed (min <sup>-1</sup> )	Air Flow (m <sup>3</sup> /min) (CFM)	Static Pressure (Pa) (inchH <sub>2</sub> O)	Noise (dB [A])	Operating Temperature Range (°C)	Life Expectancy (h)
109P0912T4H122(123)	12	10.2~13.8	0.2	2.4	3,000	1.52 53.7	50.0 0.201	35	-10 ~ +60	40,000
			0.1	1.2	1,400	0.71 25.0	11.3 0.045	18		

The numbers in ( ) represent ribless models.

Note 1: The top row gives characteristics shown when the temperature is 40°C, while the bottom row gives characteristics shown when the temperature is 30°C.

Note 2: The noise levels are calculated by converting measurements taken at 30cm to those measured at 1m.

Thermal Speed Controlled Fans

### Air Flow and Static Pressure Characteristics

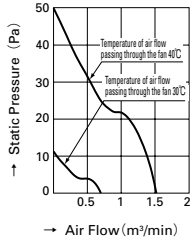

109P0912T4H122(123)

### Typical characteristics of temperature of air flowing through the fan versus rotation speed

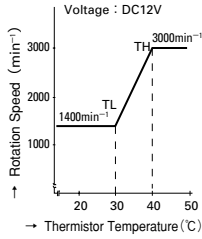

109P0912T4H122(123)

### Dimensions (unit : mm)

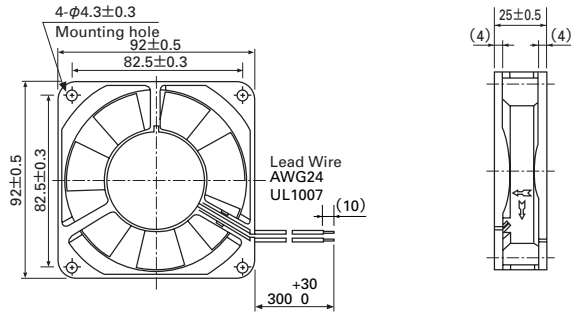

### Reference dimension of mounting holes and vent opening (unit : mm)

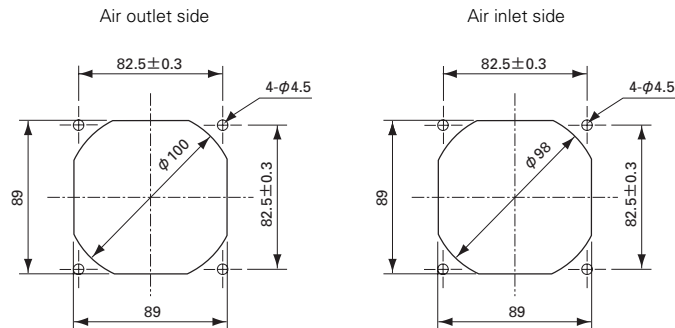

92mm

Thermal Speed  
Controlled Fans

# Thermal Speed Controlled Fan 120mm San Ace 120



Photo: externally-mounted thermistor

## General specifications

- Material ..... Frame, Impeller:Plastics
- Life Expectancy .....Varies for each model (Survival rate: 90% at 60°C, rated voltage,and continuously run in a free air state)
- Motor Protection System .....Current blocking function (with reverse polarity protection)
- Dielectric Strength .....50/60 Hz, 500VAC, 1 minute (between lead conductor and frame)
- Noise Measurement Method .....Measured at 1m from the air inlet
- Operating Temperature Range .....Varies for each model (Non-condensing)
- Lead Wire ..... ⊕red, ⊖black, (Control) brown (Only for external thermistor type)
- Fail-safe .....The motor becomes high speed when the thermistor is unable to detect the temperature in cases of open or short circuit etc.
- Mass .....210g (25mm thick) 260g (38mm thick)

## 25mm thick with an external thermistor Specifications

Model No.	Rated Voltage (V)	Operating Voltage Range (V)	Rated Current (A)	Rated Input (W)	Rated Speed (min <sup>-1</sup> )	Air Flow (m <sup>3</sup> /min) (CFM)	Static Pressure (Pa) (inchH <sub>2</sub> O)	Noise (dB [A])	Operating Temperature Range (°C)	Life Expectancy (h)
109P1212T4H12(121)	12	10.2~13.8	0.55	6.6	2,800	2.5 88.3	53.9 0.216	40	-10 ~ +60	40,000
			0.22	2.64	1,400	1.25 44.1	13.7 0.055	25		

The numbers in ( ) represent ribless models.

Notes: The top row gives characteristics shown when the thermistor temperature is 35°C, while the bottom row gives characteristics shown when the thermistor temperature is 28°C.

## 38mm thick with an external thermistor Specifications

Model No.	Rated Voltage (V)	Operating Voltage Range (V)	Rated Current (A)	Rated Input (W)	Rated Speed (min <sup>-1</sup> )	Air Flow (m <sup>3</sup> /min) (CFM)	Static Pressure (Pa) (inchH <sub>2</sub> O)	Noise (dB [A])	Operating Temperature Range (°C)	Life Expectancy (h)
109R1212T1H12(121)	12	10.2~13.8	0.48	5.75	2,600	2.9 102.4	64.7 0.260	39	-10 ~ +60	40,000
			0.23	2.76	1,300	1.4 49.4	16.2 0.065	24		

The numbers in ( ) represent ribless models.

Notes: The top row gives characteristics shown when the thermistor temperature is 35°C, while the bottom row gives characteristics shown when the thermistor temperature is 28°C.

## Air Flow and Static Pressure Characteristics

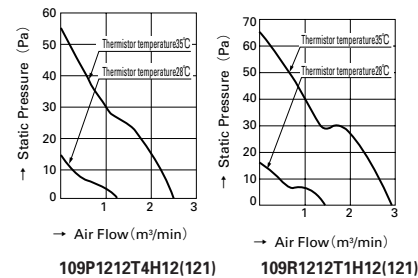

## Characteristics of Thermistor-detected Temperature vs Speed

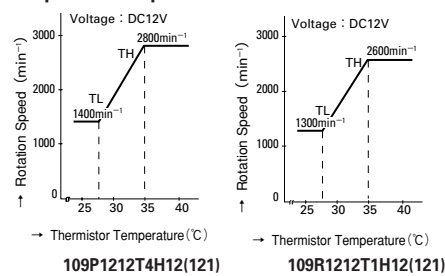

120mm

## Dimensions (unit : mm)

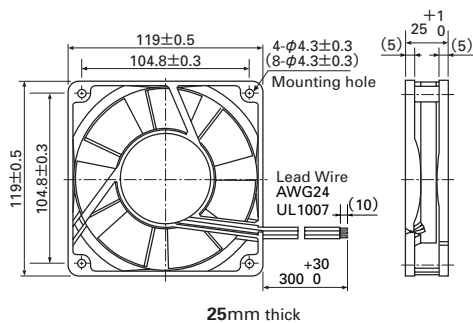

25mm thick

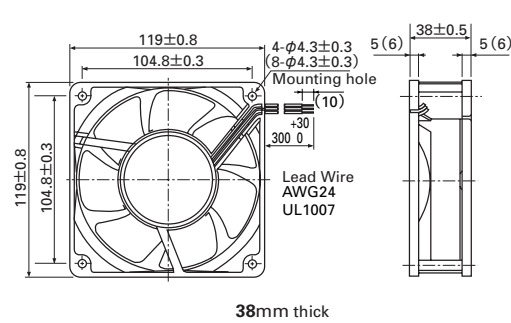

38mm thick

# 25mm thick with a built-in thermistor

## Specifications

Model No.	Rated Voltage (V)	Operating Voltage Range (V)	Rated Current (A)	Rated Input (W)	Rated Speed (min <sup>-1</sup> )	Air Flow (m <sup>3</sup> /min) (CFM)	Static Pressure (Pa) (inchH <sub>2</sub> O)	Noise (dB [A])	Operating Temperature Range (°C)	Life Expectancy (h)
<b>109P1212T4H122(123)</b>	12	10.2~13.8	0.55	6.6	2,800	2.5 88.3	53.9 0.216	40	-10 ~ +60	40,000
			0.22	2.64	1,400	1.25 44.1	13.7 0.055	25		

The numbers in ( ) represent ribless models.

Note 1: The top row gives characteristics shown when the temperature is 40°C, while the bottom row gives characteristics shown when the temperature is 30°C.

Note 2: The noise levels are calculated by converting measurements taken at 30cm to those measured at 1m.

# 38mm thick with a built-in thermistor

## Specifications

Model No.	Rated Voltage (V)	Operating Voltage Range (V)	Rated Current (A)	Rated Input (W)	Rated Speed (min <sup>-1</sup> )	Air Flow (m <sup>3</sup> /min) (CFM)	Static Pressure (Pa) (inchH <sub>2</sub> O)	Noise (dB [A])	Operating Temperature Range (°C)	Life Expectancy (h)
<b>109R1212T1H122(123)</b>	12	10.2~13.8	0.48	5.75	2,600	2.9 102.4	64.7 0.260	39	-10 ~ +60	40,000
			0.23	2.76	1,300	1.4 49.4	16.2 0.065	24		

The numbers in ( ) represent ribless models.

Note 1: The top row gives characteristics shown when the temperature is 40°C, while the bottom row gives characteristics shown when the temperature is 30°C.

Note 2: The noise levels are calculated by converting measurements taken at 30cm to those measured at 1m.

### Air Flow and Static Pressure Characteristics

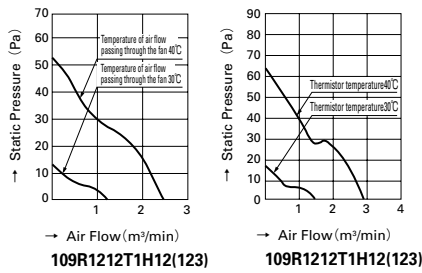

### Typical characteristics of temperature of air flowing through the fan versus rotation speed

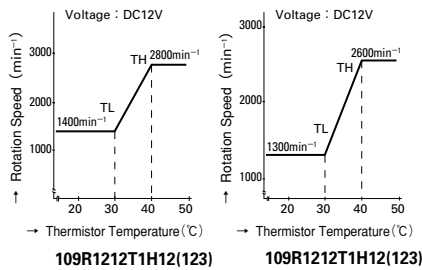

### Dimensions (unit : mm)

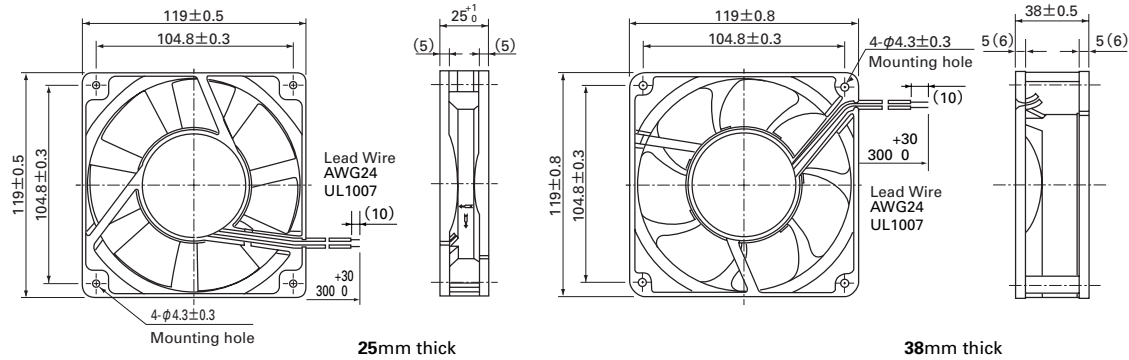

### Reference dimension of mounting holes and vent opening (unit : mm)

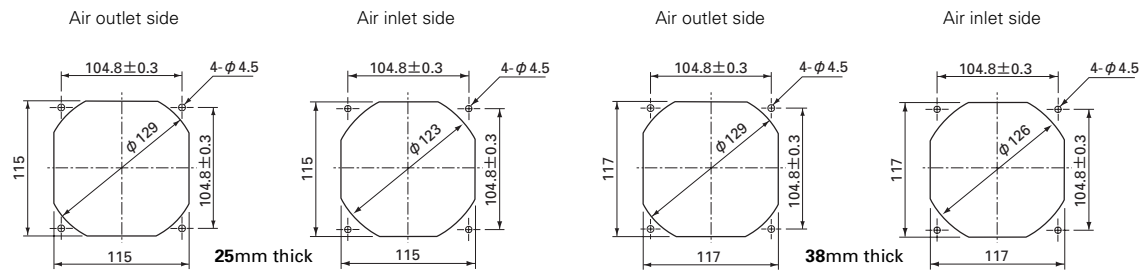

Thermal Speed Controlled Fans

120mm



# COOLING SYSTEMS

## DC FAN

## Splash Proof Fans

Splash Proof Fans

### Domain diagram

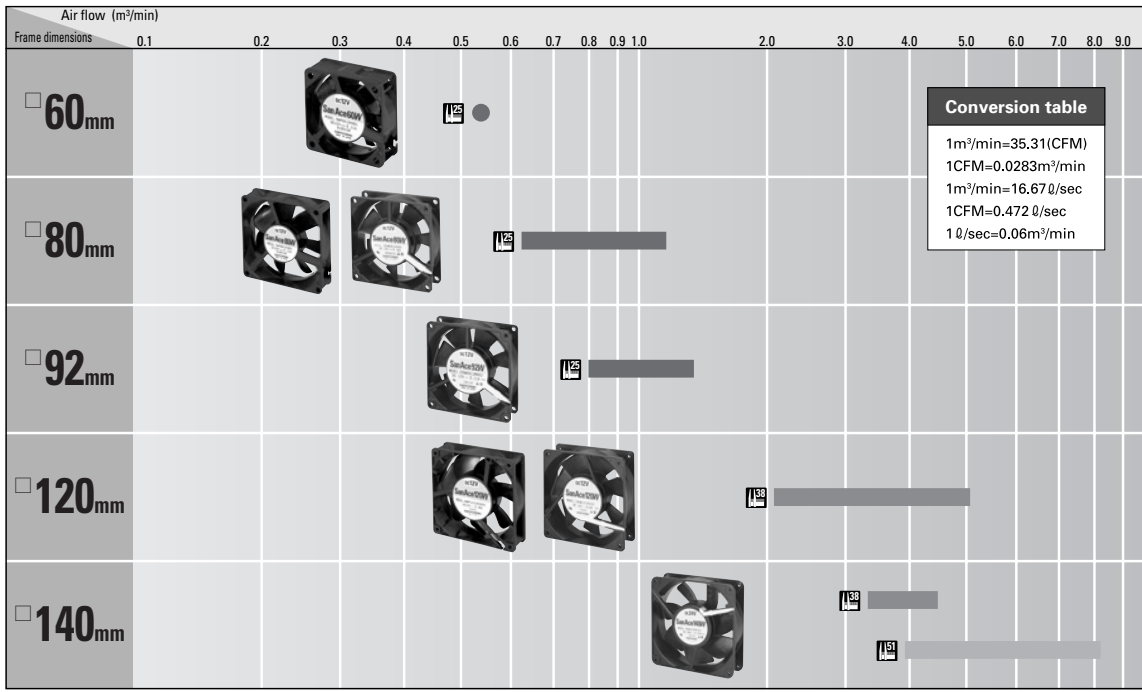

60mm  
80mm  
92mm  
120mm  
140mm

## "IP XX" Protection Grade

- IP code is laid down in "Degrees of protection provided by enclosures (IP Code) " on JIS C 0920 and IEC 60529.
- IP code is defined as "A coding system to indicate the degree of protection provided by an enclosure against access to hazardous parts, ingress of solid foreign objects, ingress of water and to give additional information in connection with such a protection"
- Regarding IP code, the first numeral indicates the degree of protection against access to hazardous parts and ingress of solid foreign objects. The second numeral indicates the degree of protection against the ingress of water.

### IP XX

**4:Protected against splashing water**

(Water splashed against the enclosure from any direction shall have no harmful effects)

**5:Protected against water jets**

(Water projected in jets against the enclosure from any direction shall have no harmful effects)

**5:Dust-Protected**

(Ingress of dust is not totally prevented, but dust shall not penetrate in a quantity to interfere with satisfactory operation of the apparatus or to impair safety.)

#### First characteristics

Degree	Type	Description
0	No protected device	Rotating device without special protection.
1	Semi-protected device	Rotating device with protection against solid objects of 50mm or larger
2	Protected device	Rotating device with protection against solid objects of 12mm or larger
3	Shielded device	Rotating device with protection against solid objects of 2.5mm or larger
4	Totally shielded device	Rotating device with protection against solid objects of 1mm or larger
5	Dust resistant device	Rotating device with protection against harmful dust ingress (dust protected)
6	Dust-proof device	Rotating device with totally protection against any dust ingress (dust tight)

#### Second characteristics

Degree	Type	Description
0	No protected device	Rotating device without special protection.
1	Drip-proof device (Grade I)	Rotating device with protection against falling water from the vertical
2	Drip-proof device (Grade II)	Rotating device with protection against falling water to a maximum of 15° from the vertical
3	Rain-proof device	Rotating device with protection against rain to a maximum of 60° from the vertical
4	Splash-proof device	Rotating device with protection against water sprays from any direction.
5	Jet-proof device	Rotating device with protection against water jets from any direction.
6	Water resistant device	Rotating device with protection against powerful water jets from any direction and no water ingress inside of the device.
7	Water immersion-proof device	Rotating device with protection against the effects of temporary immersion in water under specific test condition.
8	Submergence-proof device	Rotating device with protection against the effects of permanent immersion in water of specific water pressure.



# Splash Proof Fan □ 60mm

## San Ace 60W



“San Ace 60W” WP type

**General specifications** IP55 (Dust resistant device with protection against water jets)

- Material ..... Frame, impeller : Plastics
- Life Expectancy ..... Varies for each model (Survival rate: 90% at 60°C, rated voltage, and continuously run in a free air state)
- Motor Protection System ..... Current blocking function (with reverse polarity protection)
- Dielectric Strength ..... 50/60 Hz, 500VAC, 1 minute (between lead conductor and frame)
- Noise Measurement Method ..... Measured at 1m from the air inlet
- Operating Temperature Range ..... Varies for each model (Non-condensing)
- Lead Wire ..... ⊕red, ⊖black
- Mass ..... 110g

## 25mm thick Specifications

Model No.	Rated Voltage (V)	Operating Voltage Range (V)	Rated Current (A)	Rated Input (W)	Rated Speed (min <sup>-1</sup> )	Air Flow (m <sup>3</sup> /min) (CFM)	Static Pressure (Pa) (inchH <sub>2</sub> O)	Noise (dB [A])	Operating Temperature Range (°C)	Life Expectancy (h)
<b>9WP0612H402(4021)</b>	12	10.2~13.8	0.11	1.32	3,800	0.53 18.7	40.2 0.161	28	-10 ~ +70	60,000
<b>9WP0624H402(4021)</b>	24	20.4~27.6	0.06	1.44	3,800	0.53 18.7	40.2 0.161	28		
<b>9WP0648H402(4021)</b>	48	40 ~53	0.04	1.92	3,800	0.53 18.7	40.2 0.161	28		

The numbers in ( ) represent ribless models.

### Air Flow and Static Pressure Characteristics

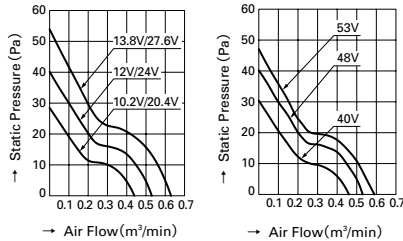

9WP0612H402(4021)  
9WP0624H402(4021)

9WP0648H402(4021)

60mm



**Dimensions (unit : mm)**

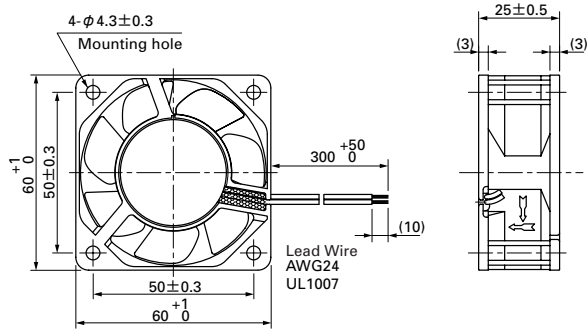

**Reference dimension of mounting holes and vent opening (unit : mm)**

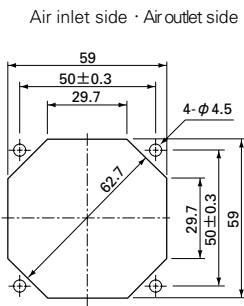

# Splash Proof Fan 80mm San Ace 80W



"San Ace 80W" W type

### General specifications

#### IP55 (Dust resistant device with protection against water jets)

- Material .....Frame:Aluminum, Impeller:Plastics
- Life Expectancy .....Varies for each model (Survival rate: 90% at 60°C,  
rated voltage,and continuously run in a free air state)
- Motor Protection System ....Current blocking function (with reverse polarity protection)
- Dielectric Strength .....50/60 Hz, 500VAC, 1 minute (between lead conductor and frame)
- Noise Measurement Method ...Measured at 1m from the air inlet
- Operating Temperature Range ....Varies for each model (Non-condensing)
- Lead Wire .....H, F speeds ⊕red,⊖black  
M, L speeds ⊕red,⊖black or blue
- Mass .....170g

## 25mm thick Specifications

Model No.	Rated Voltage (V)	Operating Voltage Range (V)	Rated Current (A)	Rated Input (W)	Rated Speed (min <sup>-1</sup> )	Air Flow (m <sup>3</sup> /min) (CFM)	Static Pressure (Pa) (inchH <sub>2</sub> O)	Noise (dB [A])	Operating Temperature Range (°C)	Life Expectancy (h)
<b>109W0812H402-U</b>	12	10.2~13.8	0.18	2.16	3,000	1.06 37.4	39.2 0.157	32	-10 ~ +70	100,000
<b>109W0812F402-U</b>			0.14	1.68	2,700	0.93 32.8	32.3 0.130	29		
<b>109W0812M402-U</b>			0.10	1.20	2,400	0.83 29.3	26.5 0.106	26		
<b>109W0812L402-U</b>			0.08	0.96	1,900	0.63 22.2	16.7 0.067	22		
<b>109W0824H402-U</b>	24	20.4~27.6	0.09	2.16	3,000	1.06 37.4	39.2 0.157	32		
<b>109W0824F402-U</b>			0.08	1.92	2,700	0.93 32.8	32.3 0.130	29		
<b>109W0824M402-U</b>			0.07	1.68	2,400	0.83 29.3	26.5 0.106	26		
<b>109W0824L402-U</b>			0.05	1.20	1,900	0.63 22.2	16.7 0.067	22		
<b>109W0848H402-U</b>	48	40.8~55.2	0.06	2.88	3,150	1.1 38.8	43.1 0.173	34		

### Air Flow and Static Pressure Characteristics

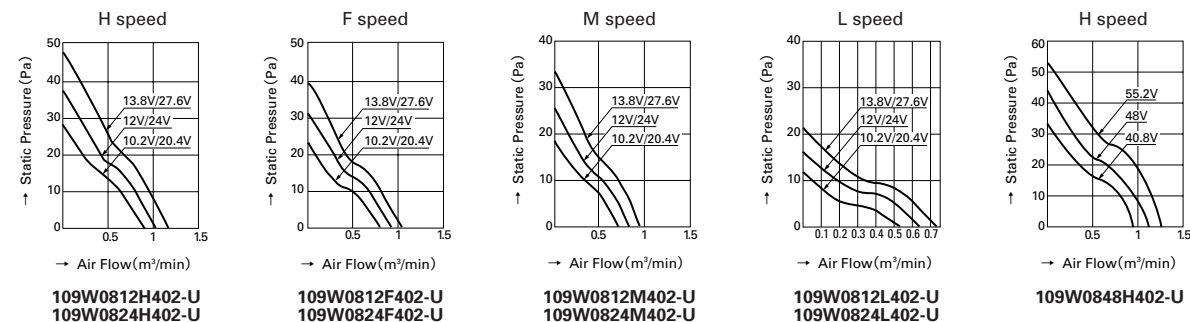

**Dimensions (unit : mm)**

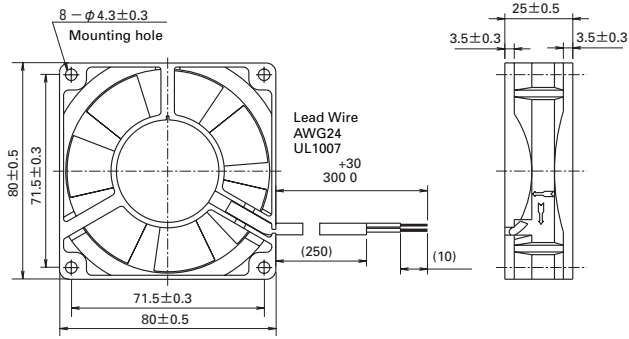

**Reference dimension of mounting holes and vent opening (unit : mm)**

Air inlet side · Air outlet side

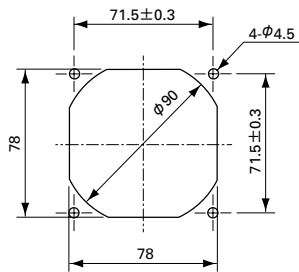

# Splash Proof Fan 80mm San Ace 80W



"San Ace 80W" WP type

**General specifications** IP55 (Dust resistant device with protection against water jets)

- Material ..... Frame, impeller : Plastics
- Life Expectancy ..... Varies for each model (Survival rate: 90% at 60°C, rated voltage, and continuously run in a free air state)
- Motor Protection System ..... Current blocking function (with reverse polarity protection)
- Dielectric Strength ..... 50/60 Hz, 500VAC, 1 minute (between lead conductor and frame)
- Noise Measurement Method ..... Measured at 1m from the air inlet
- Operating Temperature Range ..... Varies for each model (Non-condensing)
- Lead Wire ..... ⊕red, ⊖black
- Mass ..... 130g

## 25mm thick Specifications

Model No.	Rated Voltage (V)	Operating Voltage Range (V)	Rated Current (A)	Rated Input (W)	Rated Speed (min <sup>-1</sup> )	Air Flow (m <sup>3</sup> /min) (CFM)	Static Pressure (Pa) (inchH <sub>2</sub> O)	Noise (dB [A])	Operating Temperature Range (°C)	Life Expectancy (h)
<b>9WP0812H402 (4021)</b>	12	10.2~13.8	0.13	1.56	2,900	1.03 36.4	35.3 0.142	29	-10 ~ +70	60,000
<b>9WP0824H402 (4021)</b>	24	20.4~27.6	0.07	1.68	2,900	1.03 36.4	35.3 0.142	29		
<b>9WP0848S402 (4021)</b>	48	40.8~55.2	0.06	2.88	3,400	1.20 42.4	48.0 0.193	34		40,000

The numbers in ( ) represent ribless models.

### Air Flow and Static Pressure Characteristics

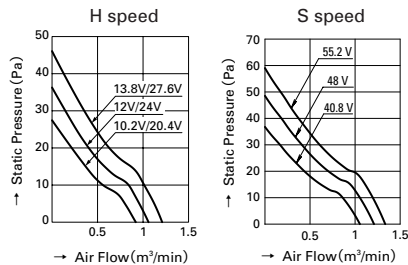

**9WP0812H402(4021)**  
**9WP0824H402(4021)**

**9WP0848S402(4021)**

80mm

**Dimensions (unit : mm)**

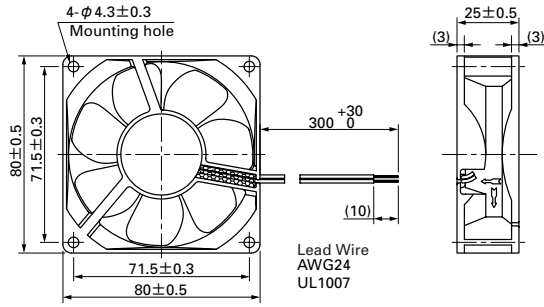

**Reference dimension of mounting holes and vent opening (unit : mm)**

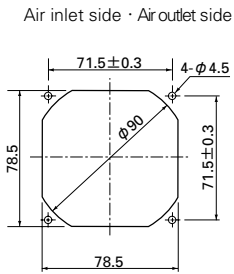

Splash Proof Fans

80mm

# Splash Proof Fan

80mm  
San Ace 80WS



Splash Proof Fans

## General specifications

### IP54 (Dust resistant device with protection against water spray)

- Material .....Frame, Impeller:Plastics
- Life Expectancy .....Varies for each model (Survival rate: 90% at 60°C, rated voltage,and continuously run in a free air state)
- Motor Protection System .....Current blocking function (with reverse polarity protection)
- Dielectric Strength .....50/60 Hz, 500VAC, 1 minute (between lead conductor and frame)
- Noise Measurement Method .....Measured at 1m from the air inlet
- Operating Temperature Range .....Varies for each model (Non-condensing)
- Lead Wire .....H, F speeds ⊕red,⊖black  
M speed ⊕red,⊖black or blue
- Mass .....120g

## 25mm thick Specifications

Model No.	Rated Voltage (V)	Operating Voltage Range (V)	Rated Current (A)	Rated Input (W)	Rated Speed (min <sup>-1</sup> )	Air Flow (m <sup>3</sup> /min) (CFM)	Static Pressure (Pa) (inchH <sub>2</sub> O)	Noise (dB [A])	Operating Temperature Range (°C)	Life Expectancy (h)
9WS0812H402(4021)	12	10.2~13.8	0.16	1.92	3,100	0.94 33.2	45.1 0.181	32	-10 ~+70	40,000
9WS0812F402(4021)			0.13	1.56	2,700	0.83 29.3	34.3 0.138	28		
9WS0812M402(4021)			0.1	1.2	2,200	0.65 23.0	23.5 0.094	23		
9WS0824H402(4021)	24	20.4~27.6	0.09	2.16	3,100	0.94 33.2	45.1 0.181	32		
9WS0824F402(4021)			0.07	1.68	2,700	0.83 29.3	34.3 0.138	28		
9WS0824M402(4021)			0.05	1.2	2,200	0.65 23.0	23.5 0.094	23		

The numbers in ( ) represent ribless models.

## Air Flow and Static Pressure Characteristics

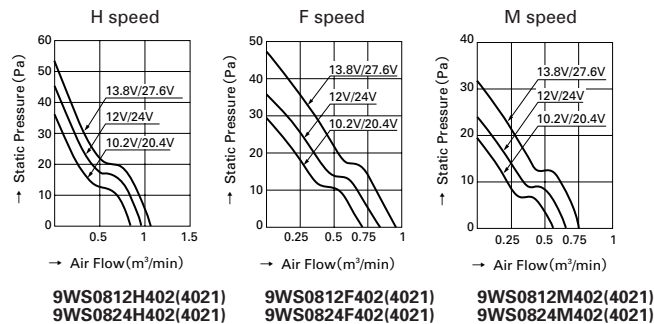

**Dimensions (unit : mm)**

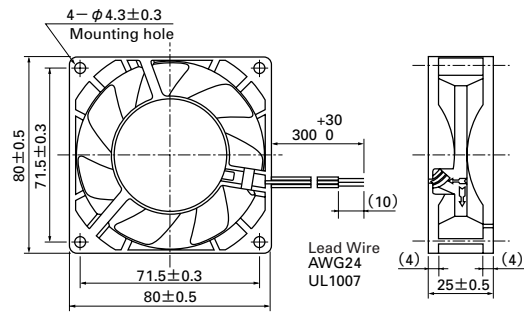

**Reference dimension of mounting holes and vent opening (unit : mm)**

Air inlet side · Air outlet side

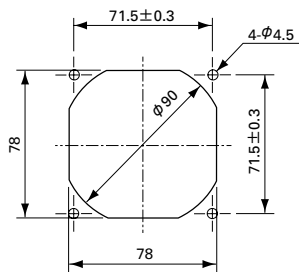

# Splash Proof Fan

92mm  
San Ace 92W



“San Ace 92W” W type

## General specifications

### IP55 (Dust resistant device with protection against water jets)

- Material .....Frame:Aluminum, Impeller:Plastics
- Life Expectancy .....Varies for each model (Survival rate: 90% at 60°C, rated voltage,and continuously run in a free air state)
- Motor Protection System ....Current blocking function (with reverse polarity protection)
- Dielectric Strength .....50/60 Hz, 500VAC, 1 minute (between lead conductor and frame)
- Noise Measurement Method ...Measured at 1m from the air inlet
- Operating Temperature Range .....Varies for each model (Non-condensing)
- Lead Wire .....H, F speeds ⊕red,⊖black  
M, L speeds ⊕red,⊖black or blue
- Mass .....190g

## 25mm thick Specifications

Model No.	Rated Voltage (V)	Operating Voltage Range (V)	Rated Current (A)	Rated Input (W)	Rated Speed (min <sup>-1</sup> )	Air Flow (m <sup>3</sup> /min) (CFM)	Static Pressure (Pa) (inchH <sub>2</sub> O)	Noise (dB [A])	Operating Temperature Range (°C)	Life Expectancy (h)
<b>109W0912H402-U</b>	12	10.2~13.8	0.21	2.52	2,850	1.38 48.7	45.1 0.181	33	-10 ~ +70	100,000
<b>109W0912F402-U</b>			0.14	1.68	2,450	1.18 41.7	32.3 0.130	30		
<b>109W0912M402-U</b>			0.11	1.32	2,100	1.01 35.7	23.5 0.094	27		
<b>109W0912L402-U</b>			0.08	0.96	1,700	0.80 28.2	16.7 0.067	23		
<b>109W0924H402-U</b>	24	20.4~27.6	0.12	2.88	2,850	1.38 48.7	45.1 0.181	33		
<b>109W0924F402-U</b>			0.08	1.92	2,450	1.18 41.7	32.3 0.130	30		
<b>109W0924M402-U</b>			0.06	1.44	2,100	1.01 35.7	23.5 0.094	27		
<b>109W0924L402-U</b>			0.05	1.2	1,700	0.80 28.2	16.7 0.067	23		
<b>109W0948H402-U</b>	48	40.8~55.2	0.06	2.88	2,850	1.38 48.7	45.1 0.181	33		

## Air Flow and Static Pressure Characteristics

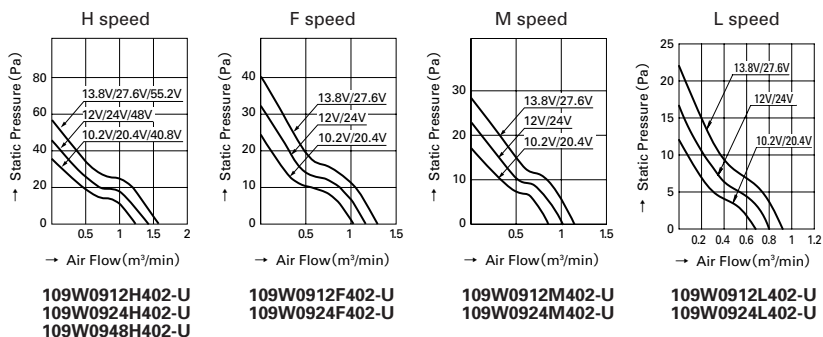

92mm



**Dimensions (unit : mm)**

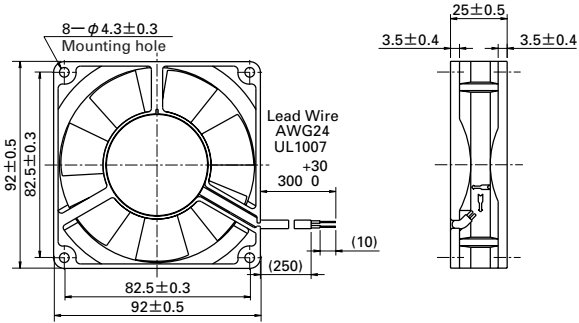

Splash Proof Fans

**Reference dimension of mounting holes and vent opening (unit : mm)**

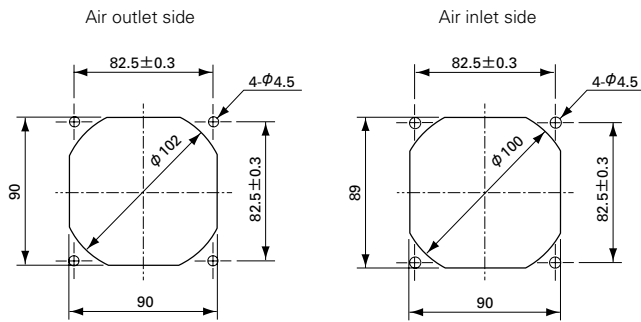

92mm

# Splash Proof Fan

92mm  
San Ace 92WS



Splash Proof Fans

## General specifications

### IP54 (Dust resistant device with protection against water spray)

- Material .....Frame, impeller : Plastics
- Life Expectancy .....Varies for each model (Survival rate: 90% at 60°C, rated voltage, and continuously run in a free air state)
- Motor Protection System .....Current blocking function (with reverse polarity protection)
- Dielectric Strength .....50/60 Hz, 500VAC, 1 minute (between lead conductor and frame)
- Noise Measurement Method .....Measured at 1m from the air inlet
- Operating Temperature Range .....Varies for each model (Non-condensing)
- Lead Wire .....H, F speeds ⊕red, ⊖black  
M, L speeds ⊕red, ⊖black or blue
- Mass .....150g

## 25mm thick Specifications

Model No.	Rated Voltage (V)	Operating Voltage Range (V)	Rated Current (A)	Rated Input (W)	Rated Speed (min <sup>-1</sup> )	Air Flow (m <sup>3</sup> /min) (CFM)	Static Pressure (Pa) (inchH <sub>2</sub> O)	Noise (dB [A])	Operating Temperature Range (°C)	Life Expectancy (h)
9WS0912H402	12	10.2~13.8	0.17	2.04	2,850	1.38 48.7	45.1 0.181	33	-10 ~ +70	40,000
9WS0912F402			0.13	1.56	2,450	1.18 41.7	32.3 0.130	30		
9WS0912M402			0.1	1.2	2,100	1.01 35.7	23.5 0.094	27		
9WS0912L402			0.06	0.72	1,700	0.8 28.2	16.7 0.067	23		
9WS0924H402	24	20.4~27.6	0.1	2.4	2,850	1.38 48.7	45.1 0.181	33		
9WS0924F402			0.07	1.68	2,450	1.18 41.7	32.3 0.130	30		
9WS0924M402			0.06	1.44	2,100	1.01 35.7	23.5 0.094	27		
9WS0924L402			0.05	1.2	1,700	0.8 28.2	16.7 0.067	23		

## Air Flow and Static Pressure Characteristics

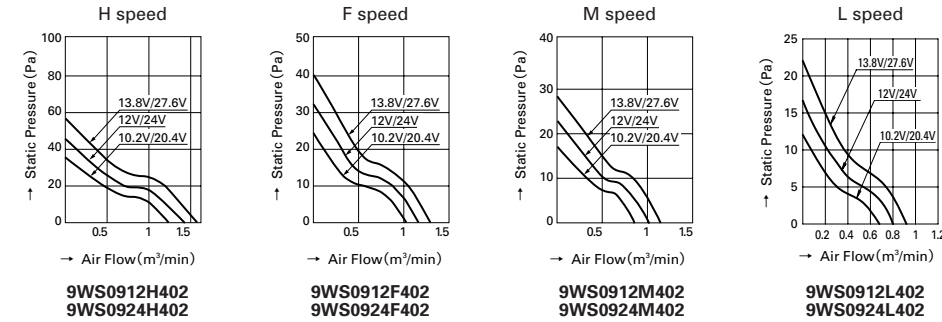

**Dimensions (unit : mm)**

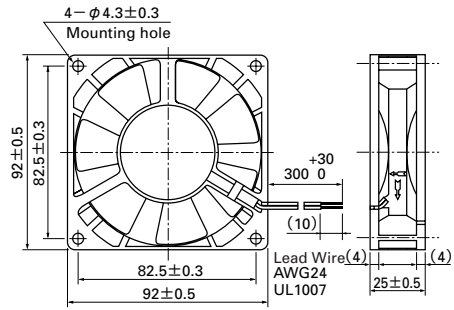

Splash Proof Fans

**Reference dimension of mounting holes and vent opening (unit : mm)**

Air inlet side · Air outlet side

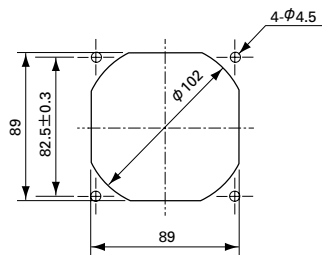

92mm

# Splash Proof Fan □ 120mm

## San Ace 120W



“San Ace 120W” W type

### General specifications

#### IP55 (Dust resistant device with protection against water jets)

- Material .....Frame:Aluminum, Impeller:Plastics
- Life Expectancy .....Varies for each model (Survival rate: 90% at 60°C, rated voltage,and continuously run in a free air state)
- Motor Protection System .....Current blocking function (with reverse polarity protection)
- Dielectric Strength .....50/60 Hz, 500VAC, 1 minute (between lead conductor and frame)
- Noise Measurement Method .....Measured at 1m from the air inlet
- Operating Temperature Range .....Varies for each model (Non-condensing)
- Lead Wire .....H speed ⊕red,⊖black  
M speed ⊕red,⊖black or blue
- Mass .....420g

### 38mm thick Specifications

Model No.	Rated Voltage (V)	Operating Voltage Range (V)	Rated Current (A)	Rated Input (W)	Rated Speed (min <sup>-1</sup> )	Air Flow (m <sup>3</sup> /min) (CFM)	Static Pressure (Pa) (inchH <sub>2</sub> O)	Noise (dB [A])	Operating Temperature Range (°C)	Life Expectancy (h)
<b>109W1212H102-U</b>	12	10.2~13.8	0.4	4.8	2,850	3.0 106.0	70.5 0.283	41	-10 ~ +60	100,000
<b>109W1212M102-U</b>			0.22	2.64	2,150	2.25 79.4	41.1 0.165	34		
<b>109W1221H102-U</b>	21	17.8~24.2	0.24	5.04	2,850	3.0 106.0	70.5 0.283	41		
<b>109W1224H102-U</b>			0.21	5.04	2,850	3.0 106.0	70.5 0.283	41		
<b>109W1224M102-U</b>	24	20.4~27.6	0.1	2.4	2,150	2.25 79.4	41.1 0.165	34		
<b>109W1248H102-U</b>			0.12	5.76	2,850	3.0 106.0	70.5 0.283	41		
<b>109W1248M102-U</b>	48	40.8~55.2	0.06	2.88	2,150	2.25 79.4	41.1 0.165	34		

### Air Flow and Static Pressure Characteristics

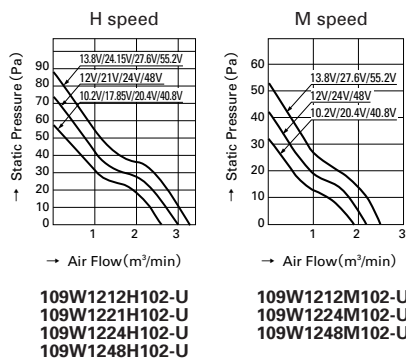

120mm

**Dimensions (unit : mm)**

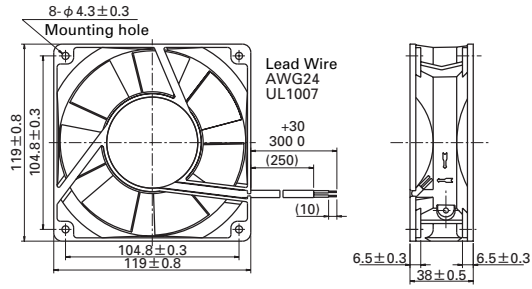

**Reference dimension of mounting holes and vent opening (unit : mm)**

Air inlet side · Air outlet side

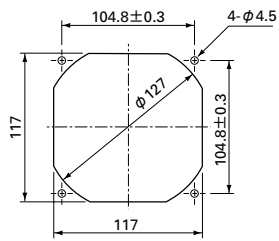

Splash Proof Fans

120mm

# Splash Proof Fan □ 120mm

## San Ace 120W



"San Ace 120W" WP type

**General specifications** IP55 (Dust resistant device with protection against water jets)

- Material .....Frame, impeller : Plastics
- Life Expectancy .....Varies for each model (Survival rate: 90% at 60°C, rated voltage, and continuously run in a free air state)
- Motor Protection System ....Current blocking function (with reverse polarity protection)
- Dielectric Strength .....50/60 Hz, 500VAC, 1 minute (between lead conductor and frame)
- Noise Measurement Method ...Measured at 1m from the air inlet
- Operating Temperature Range .....Varies for each model (Non-condensing)
- Lead Wire .....⊕red, ⊖black
- Mass .....360g

### 38mm thick Specifications

Model No.	Rated Voltage (V)	Operating Voltage range (V)	Rated Current (A)	Rated Input (W)	Rated Speed (min <sup>-1</sup> )	Air Flow (m <sup>3</sup> /min) (CFM)	Static Pressure (Pa) (inchH <sub>2</sub> O)	Noise (dB [A])	Operating Temperature Range (°C)	Life Expectancy (h)
<b>9WP1212H102 (1021)</b>	12	7 ~13.8	0.38	4.56	2,600	2.80 99	70.4 0.283	39	-10 ~+70	40,000
<b>9WP1224H102 (1021)</b>	24	14 ~27.6	0.22	5.28	2,600	2.80 99	70.4 0.283	39		
<b>9WP1248H102 (1021)</b>	48	40.8~55.2	0.11	5.28	2,600	2.80 99	70.4 0.283	39		

The numbers in ( ) represent ribless models.

### Air Flow and Static Pressure Characteristics

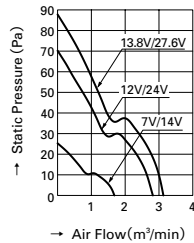

**9WP1212H102(1021)**  
**9WP1224H102(1021)**

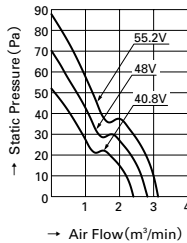

**9WP1248H102(1021)**

120mm

**Dimensions (unit : mm)**

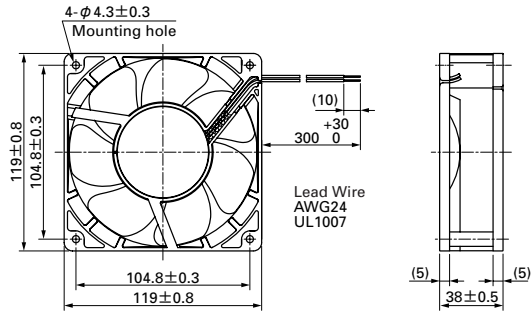

Splash-Proof Fans

**Reference dimension of mounting holes and vent opening (unit : mm)**

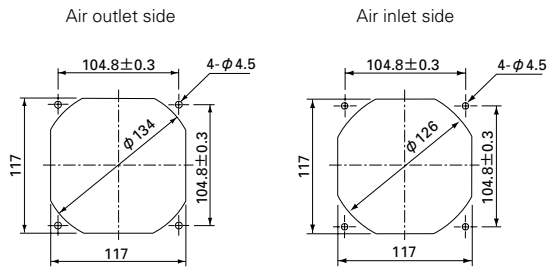

120mm

# Splash Proof Fan □ 120mm

## San Ace 120W

"San Ace 120W" G type

### General specifications

#### IP55 (Dust resistant device with protection against water jets)

Material .....Frame:Aluminum, Impeller:Plastics  
 Life Expectancy .....Varies for each model (Survival rate: 90% at 60°C,  
 rated voltage,and continuously run in a free air state)  
 Motor Protection System ....Current blocking function (with reverse polarity protection)  
 Dielectric Strength .....50/60 Hz, 500VAC, 1 minute (between lead conductor and frame)  
 Noise Measurement Method ..Measured at 1m from the air inlet  
 Operating Temperature Range .....Varies for each model (Non-condensing)  
 Lead Wire .....J, G, E, H, F speeds ⊕red,⊖black  
 M speed ⊕red,⊖black or blue  
 Mass .....410g



### 38mm thick

#### Specifications

Model No.	Rated Voltage (V)	Operating Voltage Range (V)	Rated Current (A)	Rated Input (W)	Rated Speed (min <sup>-1</sup> )	Air Flow (m <sup>3</sup> /min) (CFM)		Static Pressure (Pa) (inchH <sub>2</sub> O)		Noise (dB [A])	Operating Temperature Range (°C)	Life Expectancy (h)
9WG1212J102	12	10.2~13.8	1.90	22.8	4,800	5.10	180	230	0.924	57	-10 ~ +70	60,000
9WG1212G102			0.98	11.76	3,600	3.88	137	135	0.542	49		80,000
9WG1212E102			0.61	7.32	3,100	3.34	118	100	0.402	46		
9WG1212H102		7 ~13.8	0.38	4.56	2,600	2.80	99	70.4	0.283	39		100,000
9WG1212F102			0.28	3.36	2,280	2.45	87	54.2	0.218	36		
9WG1212M102			0.21	2.52	1,950	2.10	74	39.6	0.159	32		
9WG1224J102	24	20.4~27.6	1.00	24	4,800	5.10	180	230	0.942	57	-10 ~ +70	60,000
9WG1224G102			0.50	12	3,600	3.88	137	135	0.542	49		80,000
9WG1224E102			0.34	8.16	3,100	3.34	118	100	0.402	46		
9WG1224H102		14 ~27.6	0.22	5.28	2,600	2.80	99	70.4	0.283	39		100,000
9WG1224F102			0.16	3.84	2,280	2.45	87	54.2	0.218	36		
9WG1224M102			0.11	2.64	1,950	2.10	74	39.6	0.159	32		
9WG1248J102	48	40.8~55.2	0.51	24.48	4,800	5.10	180	230	0.924	57	-10 ~ +70	60,000
9WG1248G102			0.25	12	3,600	3.88	137	135	0.542	49		80,000
9WG1248E102			0.17	8.16	3,100	3.34	118	100	0.402	46		
9WG1248H102			0.11	5.28	2,600	2.80	99	70.4	0.283	39		100,000
9WG1248F102			0.09	4.32	2,280	2.45	87	54.2	0.218	36		
9WG1248M102			0.07	3.36	1,950	2.10	74	39.6	0.159	32		

120mm



## Air Flow and Static Pressure Characteristics

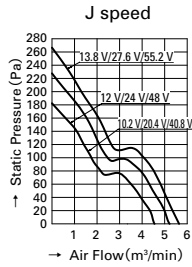

9WG1212J102  
9WG1224J102  
9WG1248J102

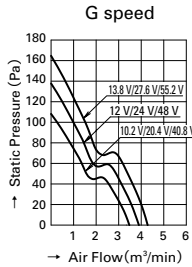

9WG1212G102  
9WG1224G102  
9WG1248G102

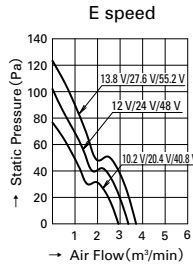

9WG1212E102  
9WG1224E102  
9WG1248E102

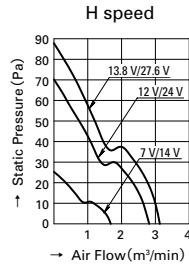

9WG1212H102  
9WG1224H102

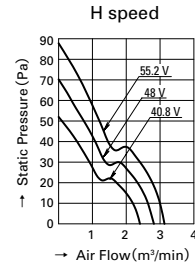

9WG1248H102

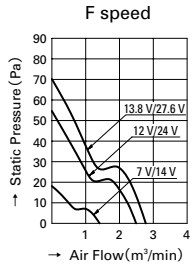

9WG1212F102  
9WG1224F102

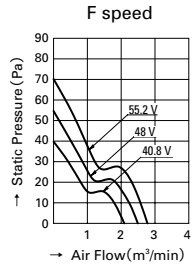

9WG1248F102

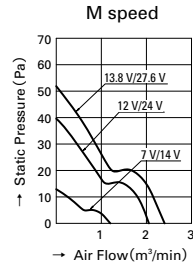

9WG1212M102  
9WG1224M102

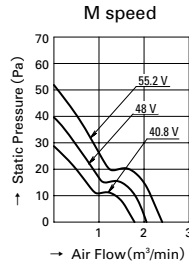

9WG1248M102

## Dimensions (unit : mm)

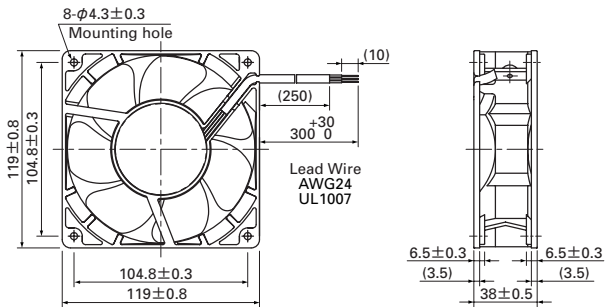

## Reference dimension of mounting holes and vent opening (unit : mm)

Air inlet side · Air outlet side

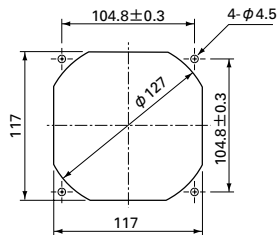

# Splash Proof Fan □ 120mm

## San Ace 120WS



### General specifications

#### IP54 (Dust resistant device with protection against water spray)

- Material .....Frame, impeller : Plastics
- Life Expectancy .....Varies for each model (Survival rate: 90% at 60°C, rated voltage, and continuously run in a free air state)
- Motor Protection System .....Current blocking function (with reverse polarity protection)
- Dielectric Strength .....50/60 Hz, 500VAC, 1 minute (between lead conductor and frame)
- Noise Measurement Method .....Measured at 1m from the air inlet
- Operating Temperature Range .....Varies for each model (Non-condensing)
- Lead Wire .....H speed ⊕red, ⊖black  
M speed ⊕red, ⊖black or blue
- Mass .....260g

### 38mm thick

#### Specifications

Model No.	Rated Voltage (V)	Operating Voltage Range (V)	Rated Current (A)	Rated Input (W)	Rated Speed (min <sup>-1</sup> )	Air Flow (m <sup>3</sup> /min) (CFM)	Static Pressure (Pa) (inchH <sub>2</sub> O)	Noise (dB [A])	Operating Temperature Range (°C)	Life Expectancy (h)
<b>9WS1212H102(1021)</b>	12	6 ~ 13.2	0.47	5.64	2,600	2.9 102.4	67.62 0.272	39	-10 ~ +60	40,000
<b>9WS1212M102(1021)</b>		6 ~ 13.8	0.23	2.76	1,950	2.2 77.7	42.14 0.169	32	-10 ~ +70	
<b>9WS1224H102(1021)</b>	24	12 ~ 26.4	0.23	5.52	2,600	2.9 102.4	67.62 0.272	39	-10 ~ +60	
<b>9WS1224M102(1021)</b>		12 ~ 27.6	0.13	3.12	1,950	2.2 77.7	42.14 0.169	32	-10 ~ +70	
<b>9WS1248H102(1021)</b>	48	40.8 ~ 52.8	0.13	6.24	2,600	2.9 102.4	67.62 0.272	39	-10 ~ +60	
<b>9WS1248M102(1021)</b>		40.8 ~ 55.2	0.07	3.36	1,950	2.2 77.7	42.14 0.169	32	-10 ~ +70	

The numbers in ( ) represent ribless models.

### Air Flow and Static Pressure Characteristics

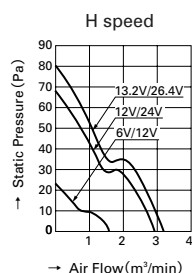

**9WS1212H102(1021)**  
**9WS1224H102(1021)**

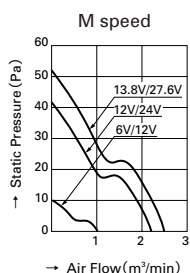

**9WS1212M102(1021)**  
**9WS1224M102(1021)**

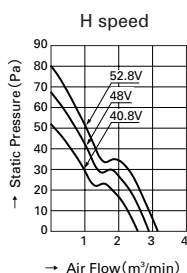

**9WS1248H102(1021)**

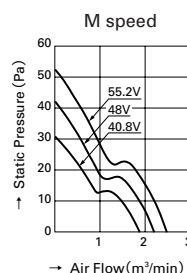

**9WS1248M102(1021)**

120mm

**Dimensions (unit : mm)**

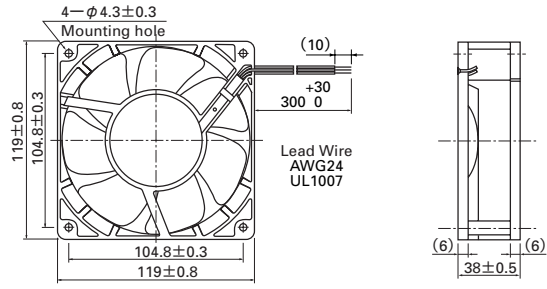

**Reference dimension of mounting holes and vent opening (unit : mm)**

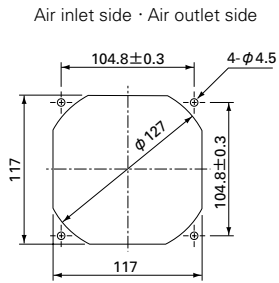

# Splash Proof Fan □ 140mm

## San Ace 140W

"San Ace 140W" W type

### General specifications

#### IP55 (Dust resistant device with protection against water jets)

- Material .....Frame:Aluminum, Impeller:Plastics
- Life Expectancy .....Varies for each model (Survival rate: 90% at 60°C, rated voltage,and continuously run in a free air state)
- Motor Protection System ....Current blocking function (with reverse polarity protection)
- Dielectric Strength .....50/60 Hz, 500VAC, 1 minute (between lead conductor and frame)
- Noise Measurement Method ..Measured at 1m from the air inlet
- Operating Temperature Range ....Varies for each model (Non-condensing)
- Lead Wire .....H, S speeds   ⊕red,⊖black  
.....M speed   ⊕red,⊖black or blue
- Mass .....650g (38mm thick) 700g (51mm thick)



## 38mm thick Specifications

Model No.	Rated Voltage (V)	Operating Voltage Range (V)	Rated Current (A)	Rated Input (W)	Rated Speed (min <sup>-1</sup> )	Air Flow (m <sup>3</sup> /min) (CFM)	Static Pressure (Pa) (inchH <sub>2</sub> O)	Noise (dB [A])	Operating Temperature Range (°C)	Life Expectancy (h)
109W1412H102-U	12	10.2~13.8	0.73	8.76	2,600	4.5 159	98 0.394	46	-10 ~+60	100,000
109W1412M102-U			0.3	3.6	1,900	3.3 117	52 0.209	38		
109W1424H102-U	24	20.4~27.6	0.37	8.88	2,600	4.5 159	98 0.394	46		
109W1424M102-U			0.16	3.84	1,900	3.3 117	52 0.209	38		
109W1448H102-U	48	40.8~55.2	0.2	9.6	2,600	4.5 159	98 0.394	46		
109W1448M102-U			0.09	4.32	1,900	3.3 117	52 0.209	38		

### Air Flow and Static Pressure Characteristics

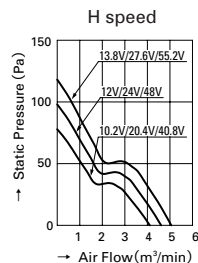

109W1412H102-U  
109W1424H102-U  
109W1448H102-U

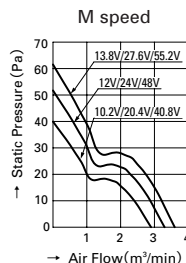

109W1412M102-U  
109W1424M102-U  
109W1448M102-U

## 51mm thick Specifications

Model No.	Rated Voltage (V)	Operating Voltage Range (V)	Rated Current (A)	Rated Input (W)	Rated Speed (min <sup>-1</sup> )	Air Flow (m <sup>3</sup> /min) (CFM)	Static Pressure (Pa) (inchH <sub>2</sub> O)	Noise (dB [A])	Operating Temperature Range (°C)	Life Expectancy (h)
9WB1412S502	12	10.2~13.8	2.7	32.4	4,200	8.1 286	240 0.964	57	-10 ~+70	60,000
9WB1412H502			1.25	15	3,100	5.9 208	130 0.522	49		
9WB1412M502	24	20.4~27.6	0.46	5.52	2,050	3.9 138	63 0.253	39		100,000
9WB1424H502			0.6	14.4	3,100	5.9 208	130 0.522	49		
9WB1424M502	48	40.8~55.2	0.22	5.28	2,050	3.9 138	63 0.253	39		60,000
9WB1448S502			0.71	34.08	4,200	8.1 286	240 0.964	57		
9WB1448H502	0.27	12.96	3,100	5.9 208	130 0.522	49	100,000			

140mm

### Air Flow and Static Pressure Characteristics

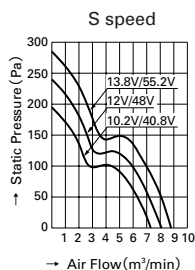

9WB1412S502  
9WB1448S502

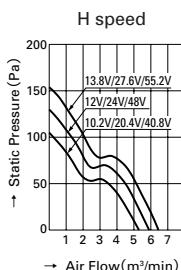

9WB1412H502  
9WB1424H502  
9WB1448H502

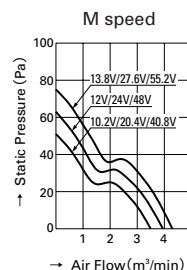

9WB1412M502  
9WB1424M502

**Dimensions (unit : mm)**

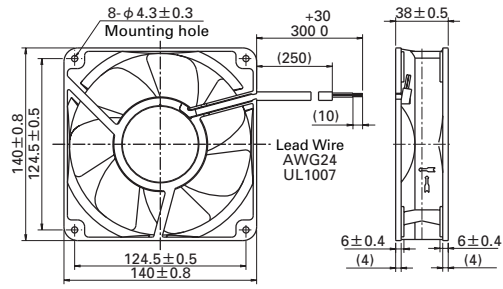

**38mm thick**

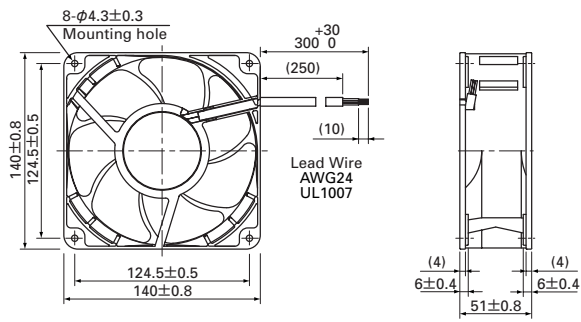

**51mm thick**

**Reference dimension of mounting holes and vent opening (unit : mm)**

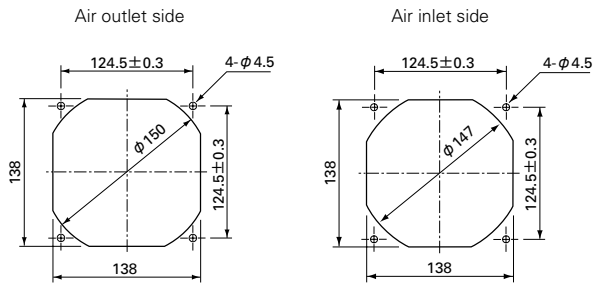



COOLING SYSTEMS

DC FAN

Oil Proof Fans

Oil Proof Fans

Domain diagram

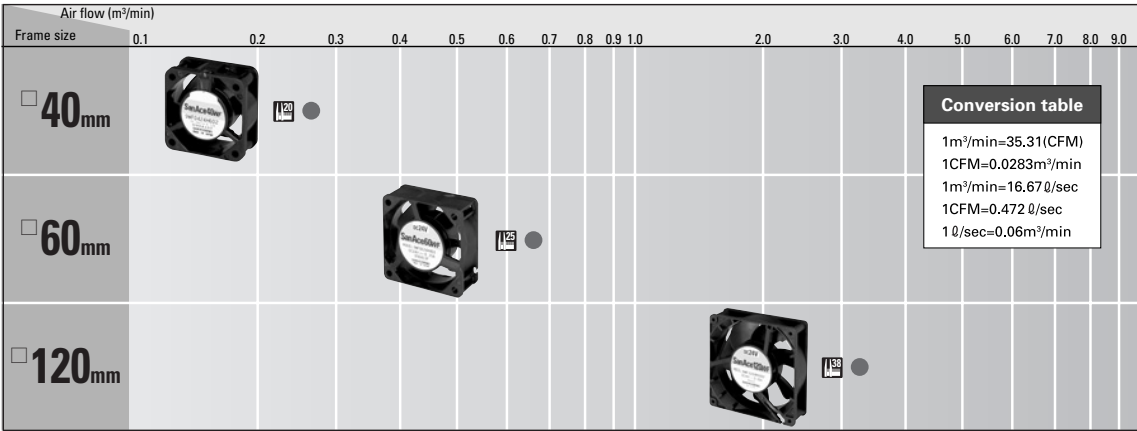

40mm

60mm

120mm

# Oil Proof Fan

40mm  
San Ace 40WF



Oil Proof Fans

**General specifications** The product can be used in an oil mist environment\*

- Material .....Frame, impeller : Plastics
- Life Expectancy .....Varies for each model (Survival rate: 90% at 60°C, rated voltage, and continuously run in a free air state)
- Motor Protection System .....Current blocking function (with reverse polarity protection)
- Dielectric Strength .....50/60 Hz, 500VAC, 1 minute (between lead conductor and frame)
- Noise Measurement Method .....Measured at 1m from the air inlet
- Operating Temperature Range .....Varies for each model (Non-condensing)
- Lead Wire .....⊕red, ⊖black
- Mass .....50g

## 20mm thick Specifications

Model No.	Rated Voltage (V)	Operating Voltage range (V)	Rated Current (A)	Rated Input (W)	Rated Speed (min <sup>-1</sup> )	Air Flow (m <sup>3</sup> /min) (CFM)	Static Pressure (Pa) (inchH <sub>2</sub> O)	Noise (dB [A])	Operating Temperature Range (°C)	Life Expectancy (h)
9WF0424H602	24	20.4~27.6	0.11	2.64	13,100	0.26 9.2	90 0.361	42	-10 ~ +70	40,000

### Air Flow and Static Pressure Characteristics

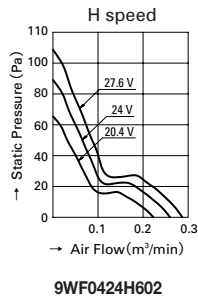

40mm

\*Environment where machining oil mist is scattered.  
Usage of this product requires an evaluation with the oil that will be used.



**Dimensions (unit : mm)**

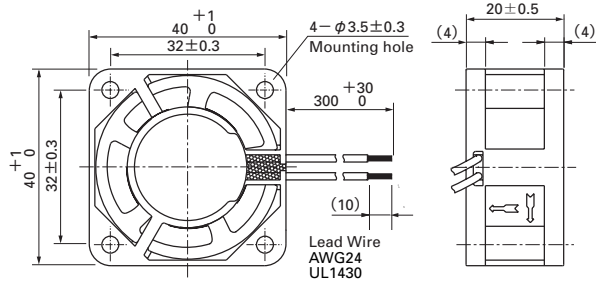

**Reference dimension of mounting holes and vent opening (unit : mm)**

Air inlet side · Air outlet side

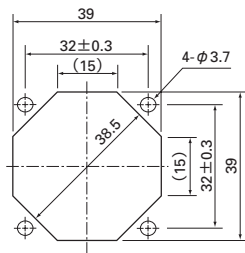

Oil Proof Fans

40mm

# Oil Proof Fan

□ **60mm**  
San Ace 60WF



Oil Proof Fans

**General specifications** The product can be used in an oil mist environment\*

- Material .....Frame, impeller : Plastics
- Life Expectancy .....Varies for each model (Survival rate: 90% at 60°C, rated voltage, and continuously run in a free air state)
- Motor Protection System .....Current blocking function (with reverse polarity protection)
- Dielectric Strength .....50/60 Hz, 500VAC, 1 minute (between lead conductor and frame)
- Noise Measurement Method .....Measured at 1m from the air inlet
- Operating Temperature Range .....Varies for each model (Non-condensing)
- Lead Wire .....⊕red, ⊖black
- Mass .....110g

## 25mm thick Specifications

Model No.	Rated Voltage (V)	Operating Voltage range (V)	Rated Current (A)	Rated Input (W)	Rated Speed (min <sup>-1</sup> )	Air Flow (m <sup>3</sup> /min) (CFM)	Static Pressure (Pa) (inchH <sub>2</sub> O)	Noise (dB [A])	Operating Temperature Range (°C)	Life Expectancy (h)
<b>9WF0624H402</b>	24	20.4~27.6	15	3.6	6,500	0.67 23.6	97 0.390	41	-10 ~+70	40,000

### Air Flow and Static Pressure Characteristics

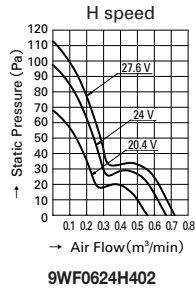

60mm

\*Environment where machining oil mist is scattered.  
Usage of this product requires an evaluation with the oil that will be used.

**Dimensions (unit : mm)**

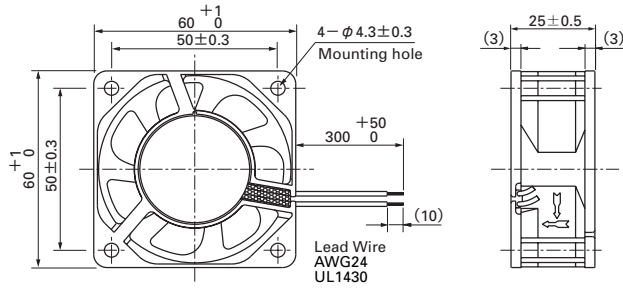

**Reference dimension of mounting holes and vent opening (unit : mm)**

Air inlet side · Air outlet side

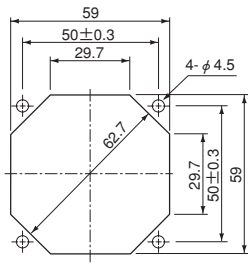

Oil Proof Fans

60mm

# Oil Proof Fan □ 120mm

## San Ace 120WF



Oil Proof Fans

### General specifications

The product can be used in an oil mist environment\*

- Material .....Frame, impeller : Plastics
- Life Expectancy .....Varies for each model (Survival rate: 90% at 60°C, rated voltage, and continuously run in a free air state)
- Motor Protection System .....Current blocking function (with reverse polarity protection)
- Dielectric Strength .....50/60 Hz, 500VAC, 1 minute (between lead conductor and frame)
- Noise Measurement Method .....Measured at 1m from the air inlet
- Operating Temperature Range .....Varies for each model (Non-condensing)
- Lead Wire .....⊕red, ⊖black
- Mass .....355g

### 38mm thick Specifications

Model No.	Rated Voltage (V)	Operating Voltage range (V)	Rated Current (A)	Rated Input (W)	Rated Speed (min <sup>-1</sup> )	Air Flow (m <sup>3</sup> /min) (CFM)	Static Pressure (Pa) (inchH <sub>2</sub> O)	Noise (dB [A])	Operating Temperature Range (°C)	Life Expectancy (h)
<b>9WF1224H102</b>	24	20.4~27.6	0.32	7.68	3,100	3.34 118	100 0.402	46	-10 ~+70	40,000

### Air Flow and Static Pressure Characteristics

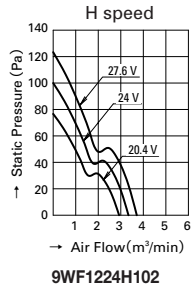

\*Environment where machining oil mist is scattered.  
Usage of this product requires an evaluation with the oil that will be used.

120mm

**Dimensions (unit : mm)**

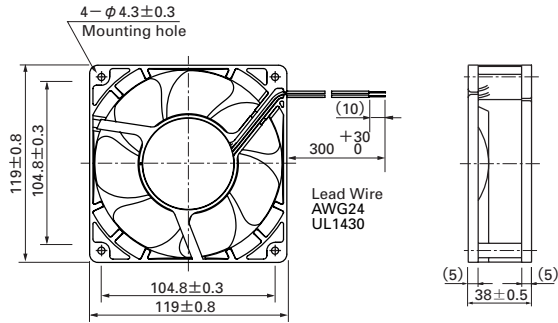

**Reference dimension of mounting holes and vent opening (unit : mm)**

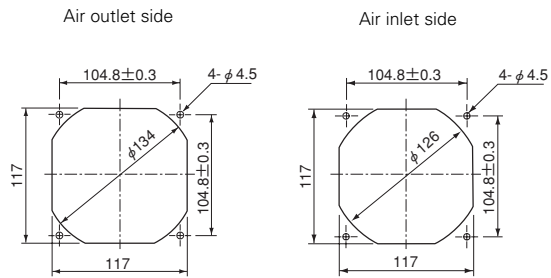

Oil Proof Fans

120mm



# COOLING SYSTEMS

## DC FAN

## Long Life Fans

Long Life Fans

### Domain diagram

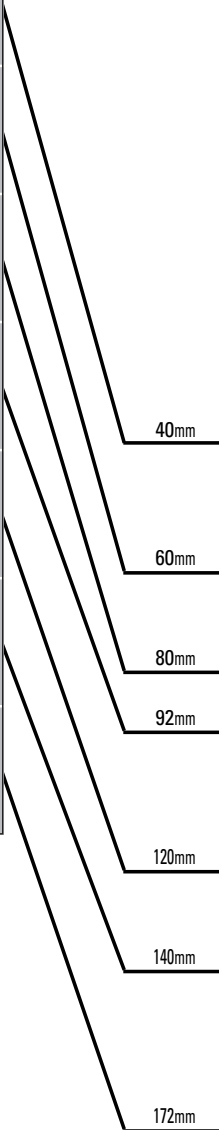
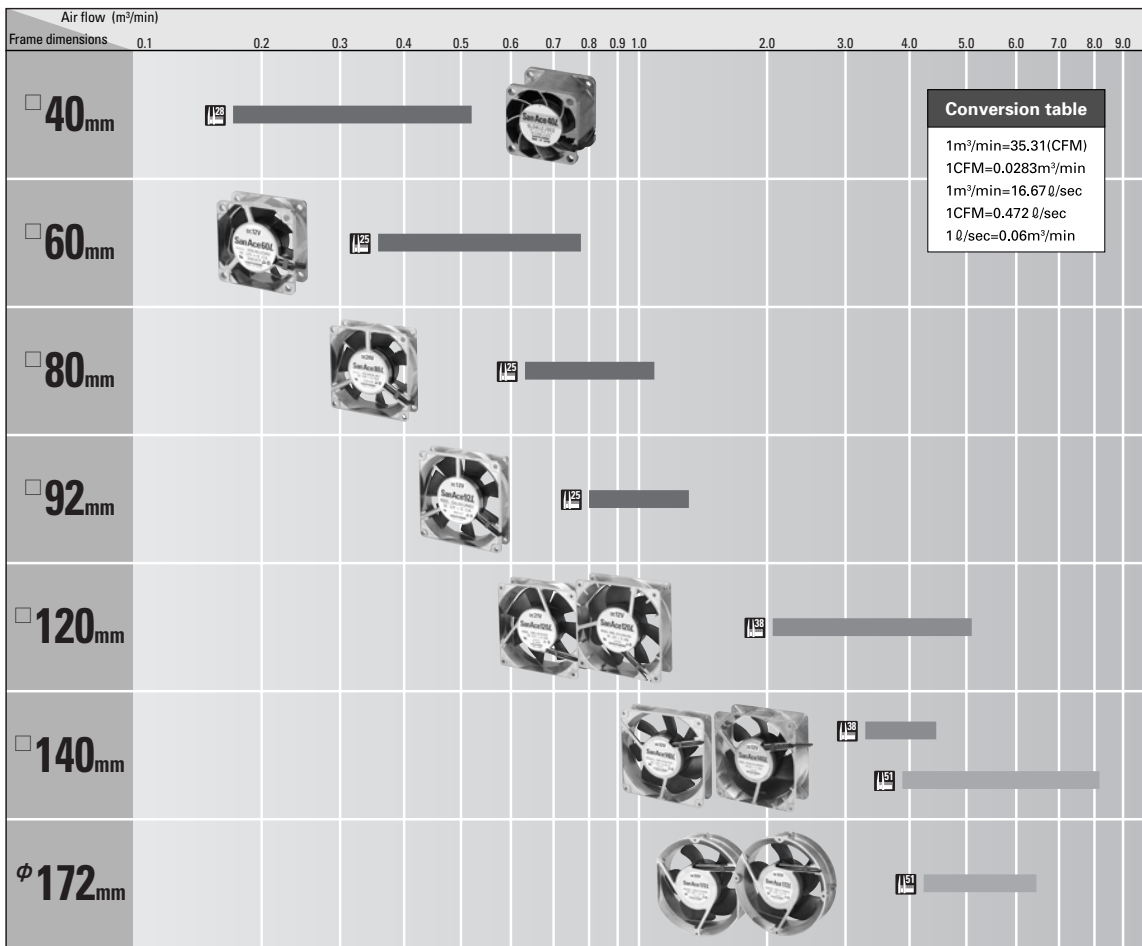

40mm

60mm

80mm

92mm

120mm

140mm

172mm

# Long Life Fan □ 40mm

## San Ace 40L



### General specifications

Material .....Frame:Aluminum, Impeller:Plastics  
 Life Expectancy .....Varies for each model (Survival rate: 90% at 60°C, rated voltage, and continuously run in a free air state)  
 Motor Protection System .....Current blocking function (with reverse polarity protection)  
 Dielectric Strength .....50/60 Hz, 500VAC, 1 minute (between lead conductor and frame)  
 Noise Measurement Method .....Measured at 1m from the air inlet  
 Operating Temperature Range .....Varies for each model (Non-condensing)  
 Lead Wire .....⊕red, ⊖black  
 Mass .....55g

Long Life Fans

## 28mm thick Specifications

Model No.	Rated Voltage (V)	Operating Voltage range (V)	Rated Current (A)	Rated Input (W)	Rated Speed (min <sup>-1</sup> )	Air Flow (m <sup>3</sup> /min) (CFM)	Static Pressure (Pa) (inchH <sub>2</sub> O)	Noise (dB [A])	Operating Temperature Range (°C)	Life Expectancy (h)
<b>9L0412J302</b>	12	10.2~13.8	0.31	3.72	11,700	0.52 18.4	206 0.827	48	-10 ~ +70	100,000
<b>9L0412H302</b>			0.15	1.80	8,400	0.37 13.1	106 0.426	40		
<b>9L0412M302</b>			0.045	0.54	4,000	0.16 5.65	24 0.096	19		

40mm

### Air Flow and Static Pressure Characteristics

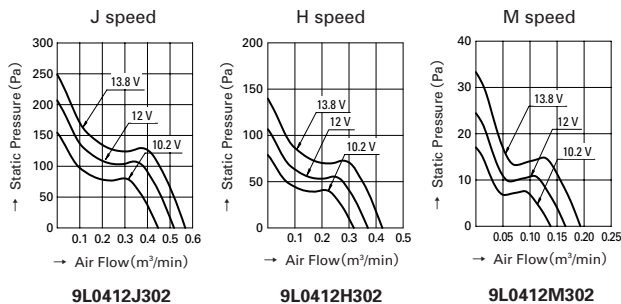



**Dimensions (unit : mm)**

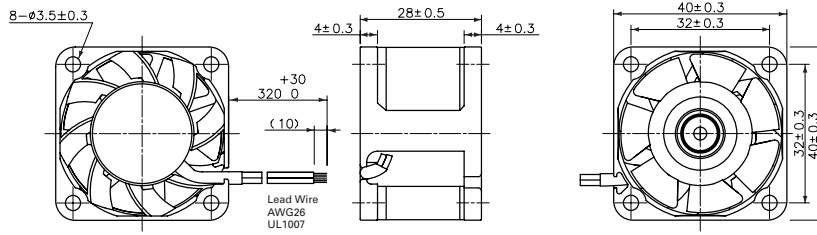

**Reference dimension of mounting holes and vent opening (unit : mm)**

Air inlet side · Air outlet side

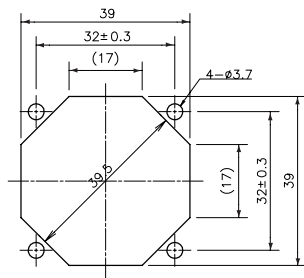

Long Life Fans

40mm

# Long Life Fan □ 60mm

## San Ace 60L



### General specifications

- Material .....Frame:Aluminum, Impeller:Plastics
- Life Expectancy .....Varies for each model (Survival rate: 90% at 60°C, rated voltage,and continuously run in a free air state)
- Motor Protection System .....Current blocking function (with reverse polarity protection)
- Dielectric Strength .....50/60 Hz, 500VAC, 1 minute (between lead conductor and frame)
- Noise Measurement Method .....Measured at 1m from the air inlet
- Operating Temperature Range .....Varies for each model (Non-condensing)
- Lead Wire .....G, S, H, F speeds ⊕red, ⊖black  
M speed ⊕red, ⊖black or blue
- Mass .....100g

Long Life Fans

## 25mm thick Specifications

Model No.	Rated Voltage (V)	Operating Voltage range (V)	Rated Current (A)	Rated Input (W)	Rated Speed (min <sup>-1</sup> )	Air Flow (m <sup>3</sup> /min) (CFM)	Static Pressure (Pa) (inchH <sub>2</sub> O)	Noise (dB [A])	Operating Temperature Range (°C)	Life Expectancy (h)
<b>109L0612G402</b>	12	10.2~13.8	0.24	2.88	5,600	0.78 27.5	87.3 0.351	39	-10 ~ +70	100,000
<b>109L0612S402</b>			0.17	2.04	4,600	0.65 23.0	57.3 0.230	33		
<b>109L0612H402</b>			0.11	1.32	3,800	0.53 18.7	40.2 0.161	28		
<b>109L0612F402</b>			0.09	1.08	3,200	0.44 15.5	29.4 0.118	24		
<b>109L0612M402</b>			0.06	0.72	2,600	0.36 12.7	19.6 0.079	20		
<b>109L0624S402</b>	24	20.4~27.6	0.08	1.92	4,600	0.65 23.0	57.3 0.230	33		
<b>109L0624H402</b>			0.06	1.44	3,800	0.53 18.7	40.2 0.161	28		
<b>109L0624F402</b>			0.05	1.20	3,200	0.44 15.5	29.4 0.118	24		
<b>109L0624M402</b>			0.04	0.96	2,600	0.36 12.7	19.6 0.079	20		
<b>109L0648G401</b>	48	40.8~55.2	0.07	3.36	5,600	0.78 27.6	87.2 0.350	39		
<b>109L0648H402</b>		40 ~53	0.04	1.92	3,800	0.53 18.7	40.2 0.161	28		

### Air Flow and Static Pressure Characteristics

60mm

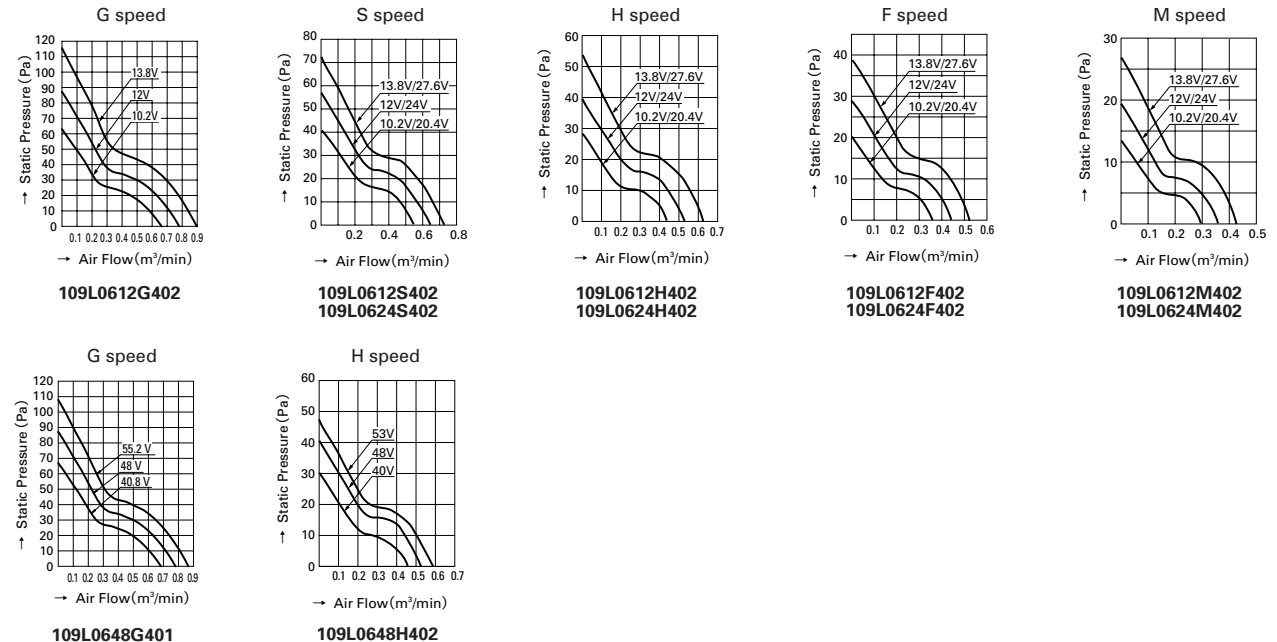

**Dimensions (unit : mm)**

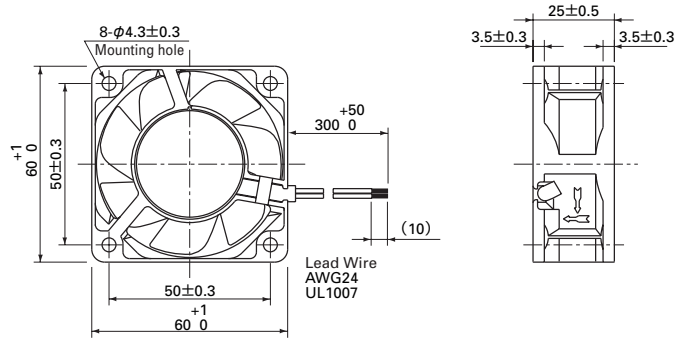

**Reference dimension of mounting holes and vent opening (unit : mm)**

Air inlet side · Air outlet side

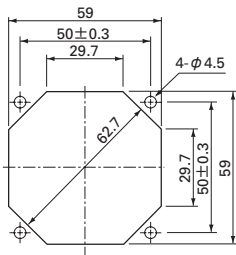

Long Life Fans

60mm

# Long Life Fan 80mm San Ace 80L



## General specifications

Material .....Frame:Aluminum, Impeller:Plastics  
 Life Expectancy .....Varies for each model (Survival rate: 90% at 60°C, rated voltage,and continuously run in a free air state)  
 Motor Protection System .....Current blocking function (with reverse polarity protection)  
 Dielectric Strength .....50/60 Hz, 500VAC, 1 minute (between lead conductor and frame)  
 Noise Measurement Method .....Measured at 1m from the air inlet  
 Operating Temperature Range .....Varies for each model (Non-condensing)  
 Lead Wire .....S, H, F speeds ⊕red,⊖black  
 M, L speeds ⊕red,⊖black or blue  
 Mass .....150g

Long Life Fans

## 25mm thick Specifications

Model No.	Rated Voltage (V)	Operating Voltage range (V)	Rated Current (A)	Rated Input (W)	Rated Speed (min <sup>-1</sup> )	Air Flow (m <sup>3</sup> /min) (CFM)	Static Pressure (Pa) (inchH <sub>2</sub> O)	Noise (dB [A])	Operating Temperature Range (°C)	Life Expectancy (h)
<b>109L0812S402</b>	12	10.2~13.8	0.26	3.12	3,400	1.2 42.4	50 0.2	37	-10 ~ +70	100,000
<b>109L0812H402</b>			0.18	2.16	3,000	1.06 37.4	39.2 0.157	32		
<b>109L0812F402</b>			0.14	1.68	2,700	0.93 32.8	32.3 0.130	29		
<b>109L0812M402</b>			0.1	1.2	2,400	0.83 29.3	26.5 0.106	26		
<b>109L0812L402</b>			0.08	0.96	1,900	0.63 22.2	16.7 0.067	22		
<b>109L0824S402</b>	24	20.4~27.6	0.11	2.64	3,400	1.2 42.4	50 0.2	37		
<b>109L0824H402</b>			0.09	2.16	3,000	1.06 37.4	39.2 0.157	32		
<b>109L0824F402</b>			0.08	1.92	2,700	0.93 32.8	32.3 0.130	29		
<b>109L0824M402</b>			0.07	1.68	2,400	0.83 29.3	26.5 0.106	26		
<b>109L0824L402</b>			0.05	1.2	1,900	0.63 22.2	16.7 0.067	22		
<b>109L0848H402</b>	48	40.8~55.2	0.06	2.88	3,150	1.1 38.8	43.1 0.173	34		

## Air Flow and Static Pressure Characteristics

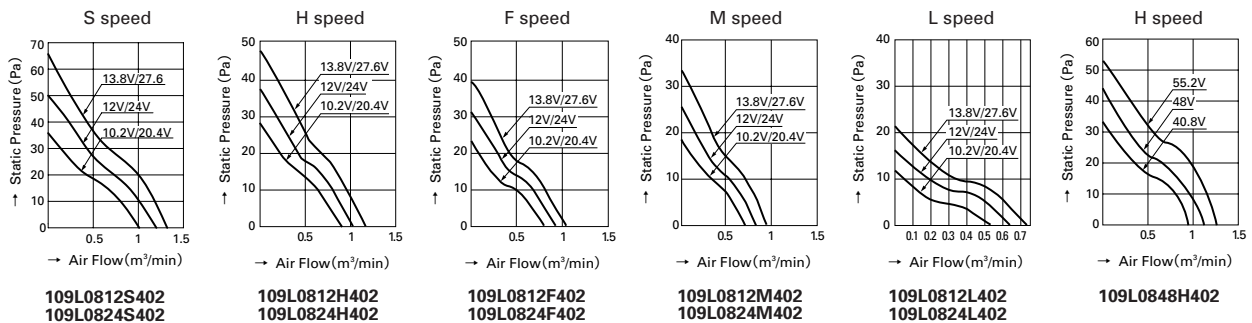

**Dimensions (unit : mm)**

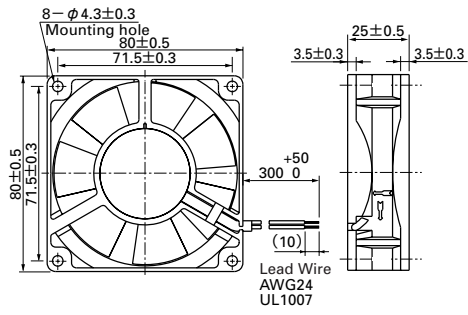

**Reference dimension of mounting holes and vent opening (unit : mm)**

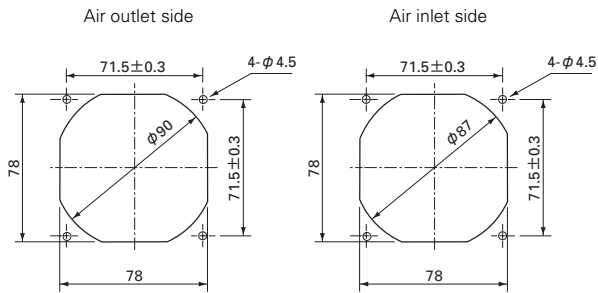

Long Life Fans

80mm



**Dimensions (unit : mm)**

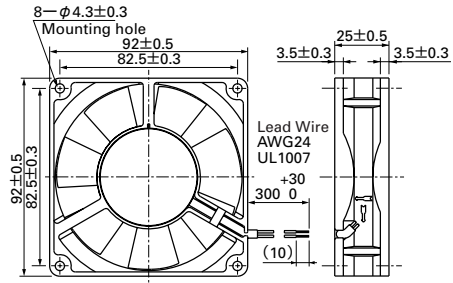

**Reference dimension of mounting holes and vent opening (unit : mm)**

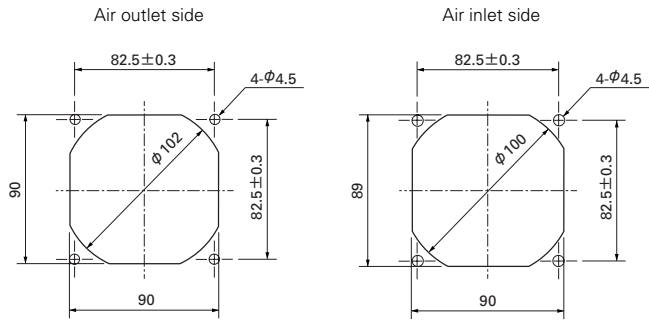

# Long Life Fan □ 120mm

## San Ace 120L



### General specifications

- Material ..... Frame:Aluminum, Impeller:Plastics
- Life Expectancy .....Varies for each model (Survival rate: 90% at 60°C, rated voltage,and continuously run in a free air state)
- Motor Protection System .....Current blocking function (with reverse polarity protection)
- Dielectric Strength .....50/60 Hz, 500VAC, 1 minute (between lead conductor and frame)
- Noise Measurement Method .....Measured at 1m from the air inlet
- Operating Temperature Range .....Varies for each model (Non-condensing)
- Lead Wire .....H speed ⊕red, ⊖black  
M speed ⊕red, ⊖black or blue
- Mass .....320g (Standard type), 370g (Low noise type)

Long Life Fans

## 38mm thick (Standard type)

### Specifications

Model No.	Rated Voltage (V)	Operating Voltage range (V)	Rated Current (A)	Rated Input (W)	Rated Speed (min <sup>-1</sup> )	Air Flow (m <sup>3</sup> /min) (CFM)	Static Pressure (Pa) (inchH <sub>2</sub> O)	Noise (dB [A])	Operating Temperature Range (°C)	Life Expectancy (h)
109L1212H102	12	10.2~13.8	0.4	4.8	2,850	3.0 106.0	70.5 0.283	41	-10 ~ +70	200,000
109L1212M102			0.22	2.64	2,150	2.25 79.4	41.1 0.165	34		
109L1221H102	21	17.8~24.2	0.24	5.04	2,850	3.0 106.0	70.5 0.283	41		
109L1224H102			0.21	5.04	2,850	3.0 106.0	70.5 0.283	41		
109L1224M102	24	20.4~27.6	0.1	2.4	2,150	2.25 79.4	41.1 0.165	34		
109L1248H102			48	40.8~55.2	0.12	5.76	2,850	3.0 106.0		
109L1248M102	0.06	2.88			2,150	2.25 79.4	41.1 0.165	34		

### Air Flow and Static Pressure Characteristics

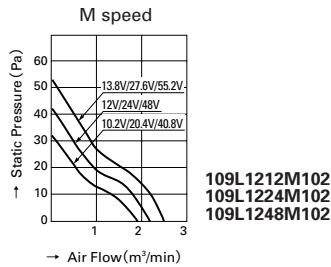
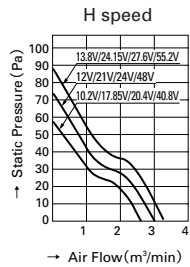

## 38mm thick (Low noise type)

### Specifications

Model No.	Rated Voltage (V)	Operating Voltage range (V)	Rated Current (A)	Rated Input (W)	Rated Speed (min <sup>-1</sup> )	Air Flow (m <sup>3</sup> /min) (CFM)	Static Pressure (Pa) (inchH <sub>2</sub> O)	Noise (dB [A])	Operating Temperature Range (°C)	Life Expectancy (h)
9LB1212H102	12	10.2~13.8	0.39	4.68	2,600	2.9 102.4	67.62 0.272	39	-10 ~ +70	200,000
9LB1212M102			0.22	2.64	2,000	2.2 77.7	42.14 0.169	32		
9LB1224H102	24	20.4~27.6	0.19	4.56	2,600	2.9 102.4	67.62 0.272	39		
9LB1224M102			0.11	2.64	2,000	2.2 77.7	42.14 0.169	32		
9LB1248H102	48	40.8~55.2	0.11	5.28	2,600	2.9 102.4	67.62 0.272	39		
9LB1248M102			0.06	2.88	2,000	2.2 77.7	42.14 0.169	32		

### Air Flow and Static Pressure Characteristics

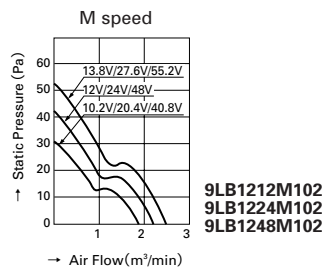
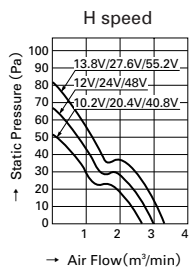

120mm



**Dimensions (unit : mm)**

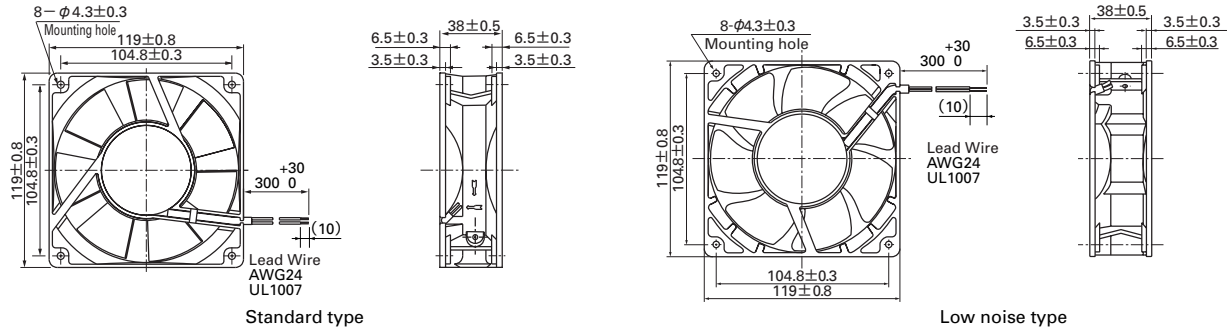

**Reference dimension of mounting holes and vent opening (unit : mm)**

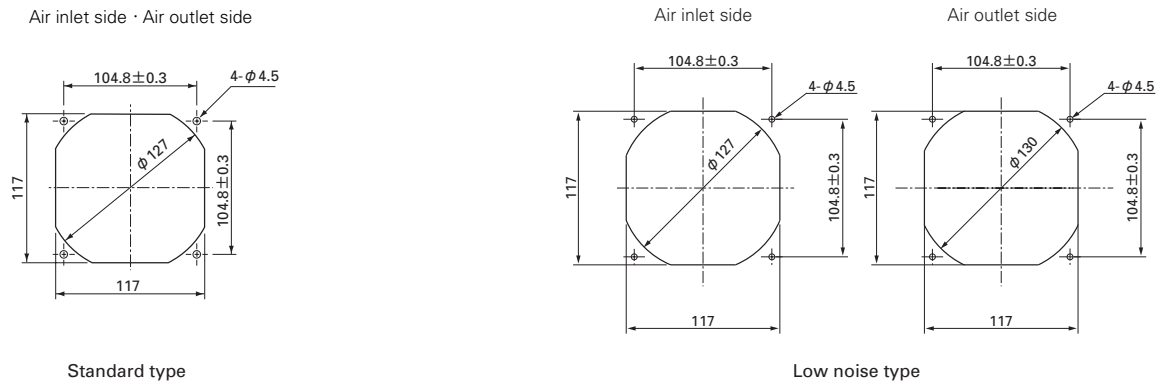

Long Life Fans

120mm

# Long Life Fan □ 120mm

## San Ace 120L

### "San Ace 120L" G Type

#### General specifications

Material .....Frame:Aluminum, Impeller:Plastics  
 Life Expectancy .....Varies for each model (Survival rate: 90% at 60°C,  
 rated voltage,and continuously run in a free air state)  
 Motor Protection System ....Current blocking function (with reverse polarity protection)  
 Dielectric Strength .....50/60 Hz, 500VAC, 1 minute (between lead conductor and frame)  
 Noise Measurement Method ..Measured at 1m from the air inlet  
 Operating Temperature Range .....Varies for each model (Non-condensing)  
 Lead Wire .....J, G, E, H, F speeds ⊕red,⊖black  
 M speed ⊕red,⊖black or blue  
 Mass .....370g



### 38mm thick

#### Specifications

Model No.	Rated Voltage (V)	Operating Voltage range (V)	Rated Current (A)	Rated Input (W)	Rated Speed (min <sup>-1</sup> )	Air Flow (m <sup>3</sup> /min) (CFM)		Static Pressure (Pa) (inchH <sub>2</sub> O)		Noise (dB [A])	Operating Temperature Range (°C)	Life Expectancy (h)
<b>9GL1212J102</b>	12	10.2~13.8	1.9	22.8	4,800	5.10	180	230	0.924	57	-10 ~ +70	60,000
<b>9GL1212G102</b>			0.98	11.8	3,600	3.88	137	135	0.542	49		80,000
<b>9GL1212E102</b>			0.61	7.32	3,100	3.34	118	100	0.402	46		100,000
<b>9GL1212H102</b>		7 ~13.8	0.38	4.56	2,600	2.80	99	70.4	0.283	39		
<b>9GL1212F102</b>			0.28	3.36	2,280	2.45	87	54.2	0.218	36		
<b>9GL1212M102</b>			0.21	2.52	1,950	2.10	74	39.6	0.159	32		
<b>9GL1224J102</b>	24	20.4~27.6	1.0	24.0	4,800	5.10	180	230	0.924	57	-10 ~ +70	60,000
<b>9GL1224G102</b>			0.50	12.0	3,600	3.88	137	135	0.542	49		80,000
<b>9GL1224E102</b>			0.34	8.16	3,100	3.34	118	100	0.402	46		100,000
<b>9GL1224H102</b>		14 ~27.6	0.22	5.28	2,600	2.80	99	70.4	0.283	39		
<b>9GL1224F102</b>			0.16	3.84	2,280	2.45	87	54.2	0.218	36		
<b>9GL1224M102</b>			0.11	2.64	1,950	2.10	74	39.6	0.159	32		
<b>9GL1248J102</b>	48	40.8~55.2	0.51	24.5	4,800	5.10	180	230	0.924	57	-10 ~ +70	60,000
<b>9GL1248G102</b>			0.25	12.0	3,600	3.88	137	135	0.542	49		80,000
<b>9GL1248E102</b>			0.17	8.16	3,100	3.34	118	100	0.402	46		100,000
<b>9GL1248H102</b>			0.11	5.28	2,600	2.80	99	70.4	0.283	39		
<b>9GL1248F102</b>			0.09	4.32	2,280	2.45	87	54.2	0.218	36		
<b>9GL1248M102</b>			0.07	3.36	1,950	2.10	74	39.6	0.159	32		

## Air Flow and Static Pressure Characteristics

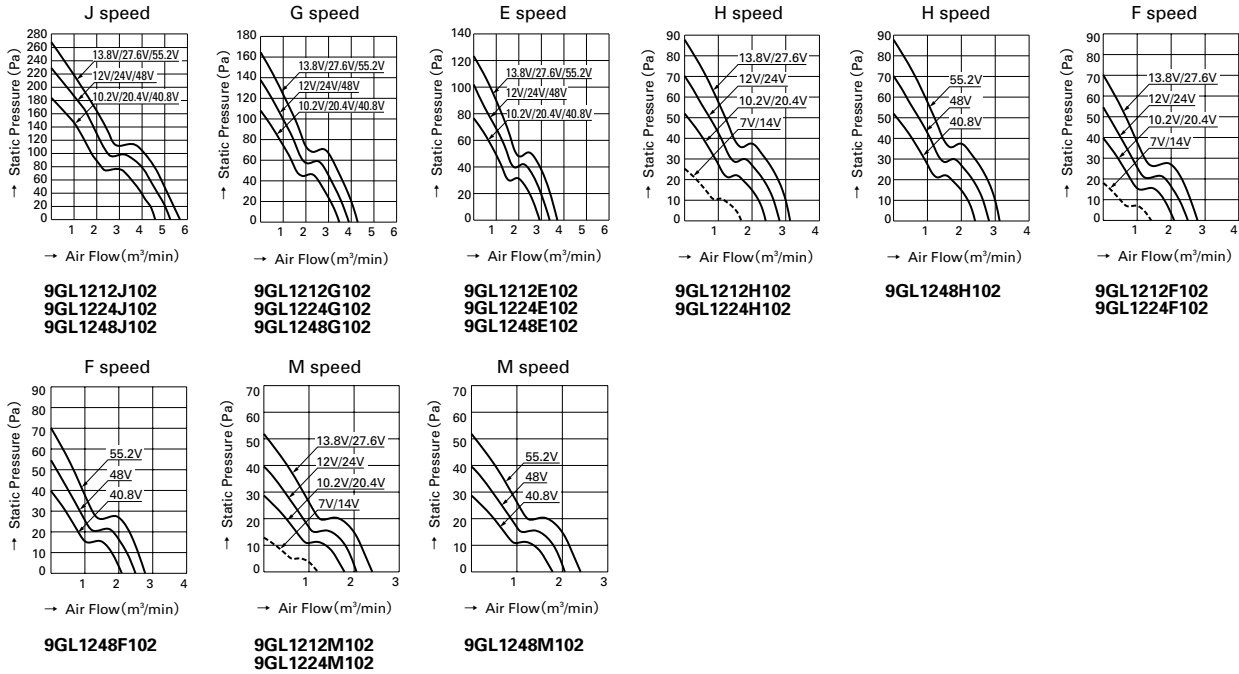

Long Life Fans

### Dimensions (unit : mm)

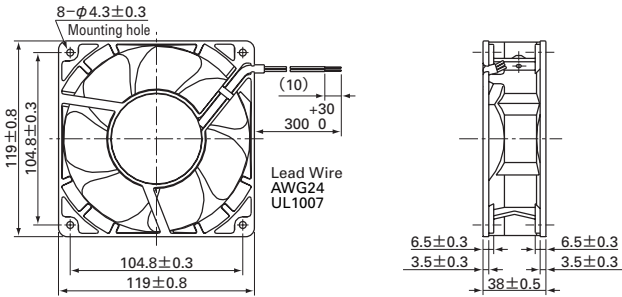

### Reference dimension of mounting holes and vent opening (unit : mm)

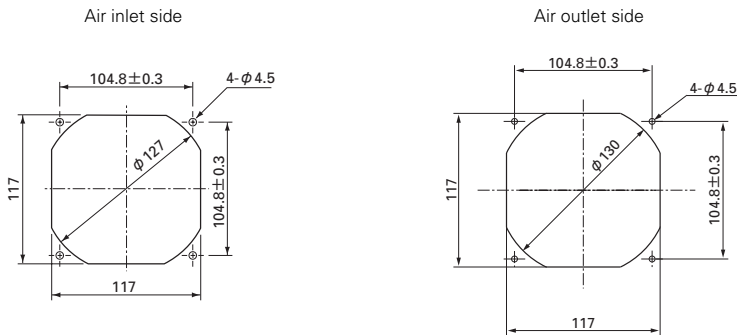

120mm

# Long Life Fan □ 140mm

## San Ace 140L



### General specifications

Material .....Frame:Aluminum, Impeller:Plastics  
 Life Expectancy .....Varies for each model (Survival rate: 90% at 60°C,  
 rated voltage,and continuously run in a free air state)  
 Motor Protection System .....Current blocking function (with reverse polarity protection)  
 Dielectric Strength .....50/60 Hz, 500VAC, 1 minute (between lead conductor and frame)  
 Noise Measurement Method .....Measured at 1m from the air inlet  
 Operating Temperature Range .....Varies for each model (Non-condensing)  
 Lead Wire .....S, H speeds ⊕red,⊖black  
 .....M speed ⊕red,⊖black or blue  
 Mass .....600g(38mm thick) ,610g(51mm thick)

Long Life Fans

### 38mm thick Specifications

Model No.	Rated Voltage (V)	Operating Voltage range (V)	Rated Current (A)	Rated Input (W)	Rated Speed (min <sup>-1</sup> )	Air Flow (m <sup>3</sup> /min) (CFM)	Static Pressure (Pa) (inchH <sub>2</sub> O)	Noise (dB [A])	Operating Temperature Range (°C)	Life Expectancy (h)
109L1412H102	12	10.2~13.8	0.73	8.76	2,600	4.5 159	98 0.394	46	-10 ~ +70	100,000
109L1412M102			0.3	3.6	1,900	3.3 117	52 0.209	38		
109L1424H102	24	20.4~27.6	0.37	8.88	2,600	4.5 159	98 0.394	46		
109L1424M102			0.16	3.84	1,900	3.3 117	52 0.209	38		
109L1448H102	48	40.8~55.2	0.2	9.6	2,600	4.5 159	98 0.394	46		
109L1448M102			0.09	4.32	1,900	3.3 117	52 0.209	38		

### Air Flow and Static Pressure Characteristics

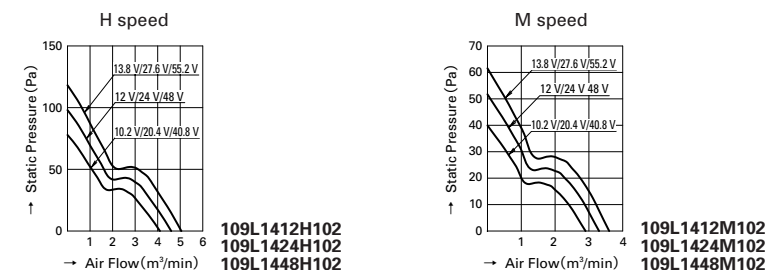

### 51mm thick Specifications

Model No.	Rated Voltage (V)	Operating Voltage range (V)	Rated Current (A)	Rated Input (W)	Rated Speed (min <sup>-1</sup> )	Air Flow (m <sup>3</sup> /min) (CFM)	Static Pressure (Pa) (inchH <sub>2</sub> O)	Noise (dB [A])	Operating Temperature Range (°C)	Life Expectancy (h)
9LB1412S502	12	10.2~13.8	2.7	32.4	4,200	8.1 286	240 0.964	57	-10 ~ +70	60,000
9LB1412H502			1.25	15.0	3,100	5.9 208	130 0.522	49		100,000
9LB1412M502			0.46	5.5	2,050	3.9 138	63 0.253	39		100,000
9LB1424S502	24	20.4~27.6	1.38	33.1	4,200	8.1 286	240 0.964	57		60,000
9LB1424H502			0.60	14.4	3,100	5.9 208	130 0.522	49		100,000
9LB1424M502			0.22	5.3	2,050	3.9 138	63 0.253	39		100,000
9LB1448S502	48	40.8~55.2	0.71	34.1	4,200	8.1 286	240 0.964	57	60,000	
9LB1448H502			0.27	13.0	3,100	5.9 208	130 0.522	49	100,000	
9LB1448M502			0.12	5.8	2,050	3.9 138	63 0.253	39	100,000	

### Air Flow and Static Pressure Characteristics

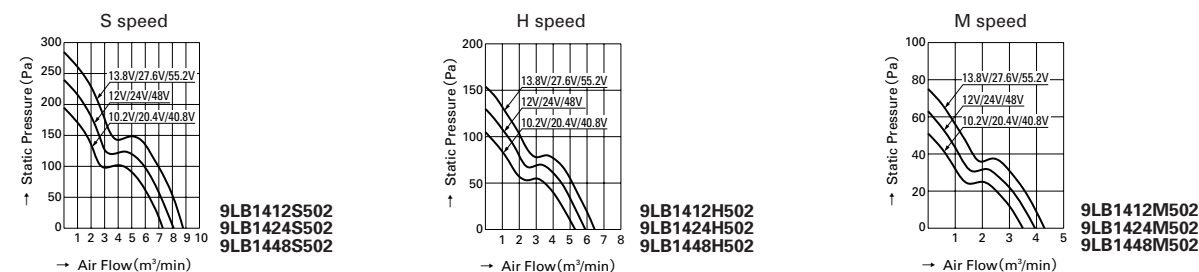

140mm

**Dimensions (unit : mm)**

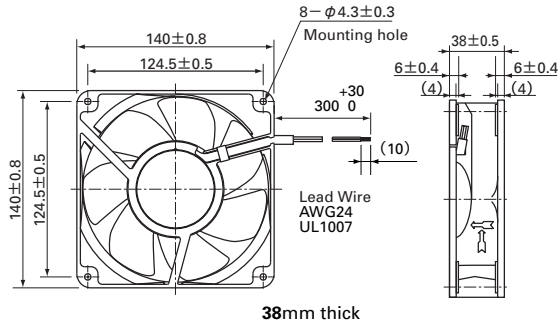

**38mm thick**

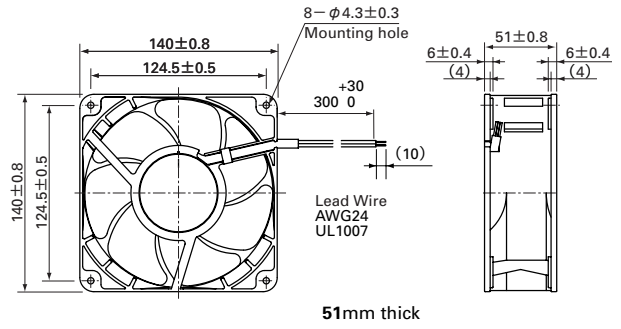

**51mm thick**

**Reference dimension of mounting holes and vent opening (unit : mm)**

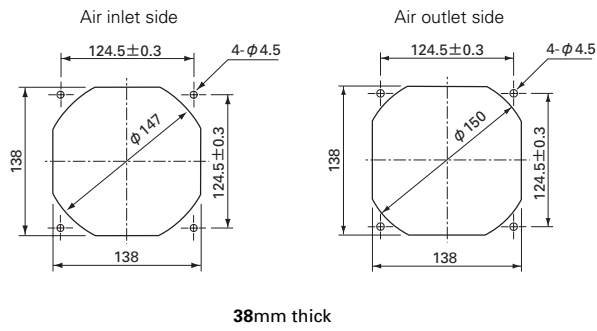

**38mm thick**

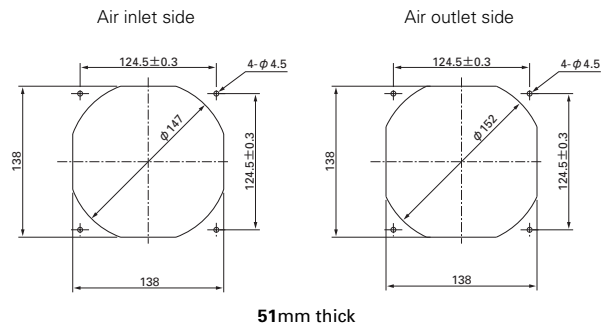

**51mm thick**

Long Life Fans

140mm



**Dimensions (unit : mm)**

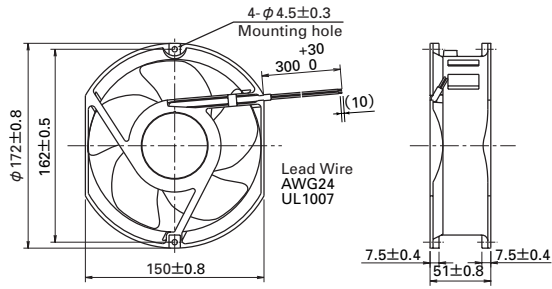

**Reference dimension of mounting holes and vent opening (unit : mm)**

Air inlet side · Air outlet side

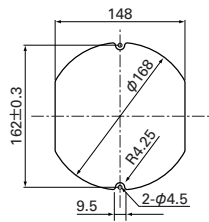

Long Life Fans

172mm





**Dimensions (unit : mm)**

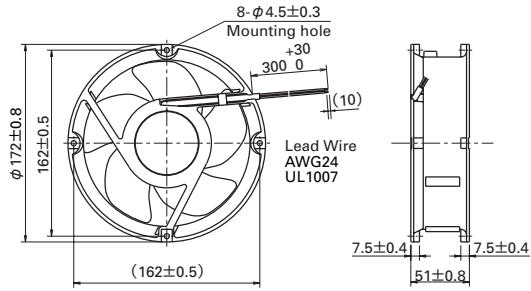

**Reference dimension of mounting holes and vent opening (unit : mm)**

Air inlet side · Air outlet side

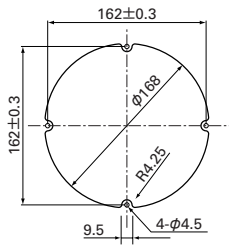

Long Life Fans

172mm



DC FAN

Blowers

Domain diagram

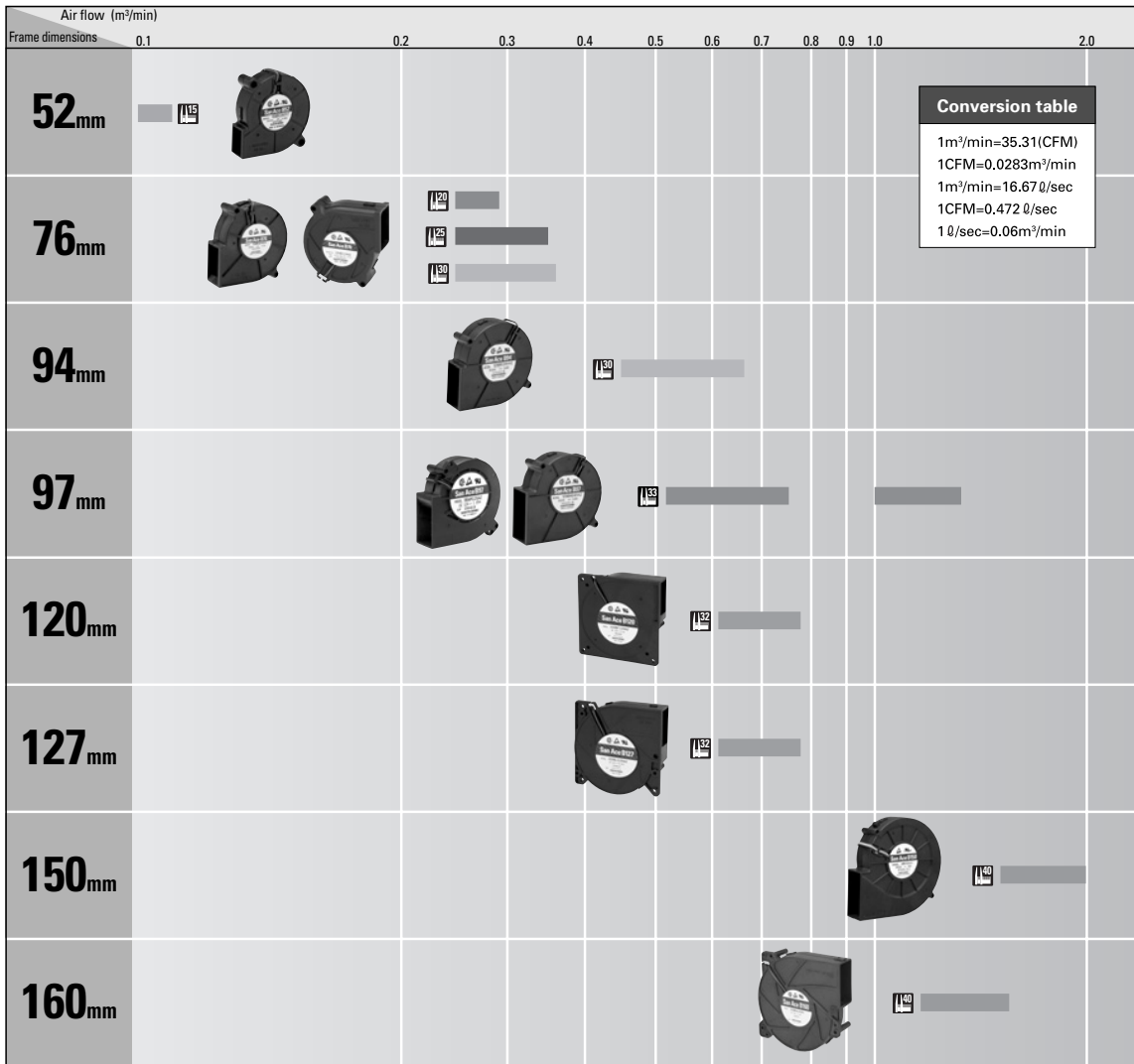

Blowers

- 52mm
- 76mm
- 94mm
- 97mm
- 120mm
- 127mm
- 150mm
- 160mm

# Blower

## 52mm San Ace B52



### General specifications

- Material ..... Frame, impeller : Plastics
- Life Expectancy ..... Varies for each model (Survival rate: 90% at 60°C, rated voltage, and continuously run in a free air state)
- Motor Protection System ..... Current blocking function (with reverse polarity protection)
- Dielectric Strength ..... 50/60 Hz, 500VAC, 1 minute (between lead conductor and frame)
- Noise Measurement Method ..... Measured at 1m from the air inlet
- Operating Temperature Range ..... Varies for each model (Non-condensing)
- Lead Wire ..... ⊕red, ⊖black
- Mass ..... 30g

Blowers

### 15mm thick Specifications

Model No.	Rated Voltage (V)	Operating Voltage Range (V)	Rated Current (A)	Rated Input (W)	Rated Speed (min <sup>-1</sup> )	Air Flow (m <sup>3</sup> /min) (CFM)	Static Pressure (Pa) (inchH <sub>2</sub> O)	Noise (dB [A])	Operating Temperature Range (°C)	Life Expectancy (h)
<b>109BC12GA7</b>	12	8.4~13.8	0.19	2.3	6,100	0.125 4.4	205 0.823	43	-20 ~ +60	30,000
<b>109BC12HA7</b>			0.15	1.8	5,500	0.117 4.1	160 0.643	40		
<b>109BC12FA7</b>		9.6~13.8	0.12	1.5	5,000	0.106 3.7	119 0.478	38		
<b>109BC12MA7</b>			0.09	1.1	4,500	0.096 3.4	96 0.386	35		
<b>109BC24GA7</b>	24	12.0~27.6	0.1	2.4	6,100	0.125 4.4	205 0.823	43		
<b>109BC24HA7</b>		15.6~27.6	0.09	2.2	5,500	0.117 4.1	160 0.643	40		
<b>109BC24FA7</b>		19.2~27.6	0.06	1.5	5,000	0.106 3.7	119 0.478	38		

### Air Flow and Static Pressure Characteristics

52mm

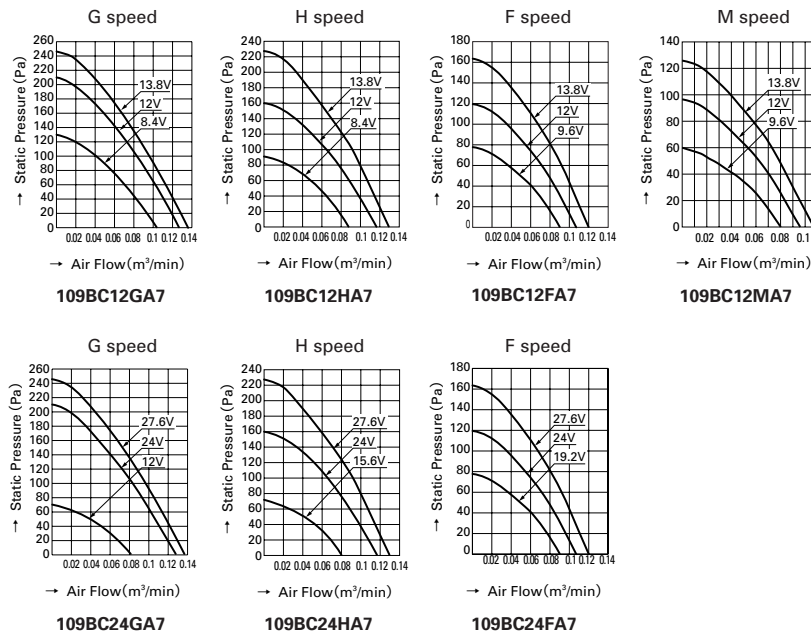

Dimensions (unit : mm)

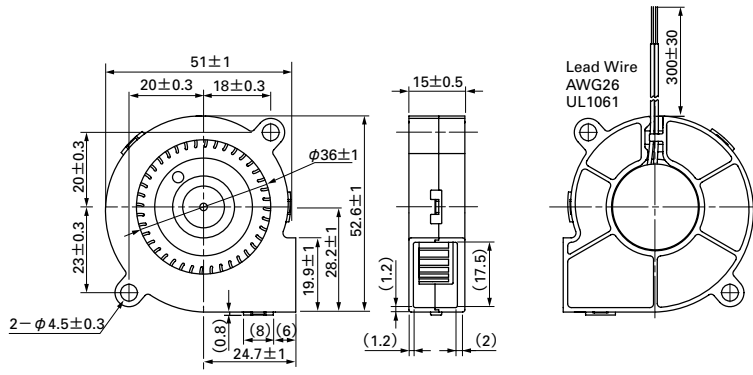

Blowers

52mm

# Blower

## 76mm San Ace B76



### General specifications

Material ..... Frame, impeller : Plastics  
 Life Expectancy ..... Varies for each model (Survival rate: 90% at 60°C, rated voltage, and continuously run in a free air state)  
 Motor Protection System ..... Current blocking function (with reverse polarity protection)  
 Dielectric Strength ..... 50/60 Hz, 500VAC, 1 minute (between lead conductor and frame)  
 Noise Measurement Method ..... Measured at 1m from the air inlet  
 Operating Temperature Range ..... Varies for each model (Non-condensing)  
 Lead Wire ..... ⊕red, ⊖black  
 Mass ..... 50g (20mm thick) 95g (25mm thick)

### 20mm thick Specifications

Model No.	Rated Voltage (V)	Operating Voltage Range (V)	Rated Current (A)	Rated Input (W)	Rated Speed (min <sup>-1</sup> )	Air Flow (m <sup>3</sup> /min) (CFM)	Static Pressure (Pa) (inchH <sub>2</sub> O)	Noise (dB [A])	Operating Temperature Range (°C)	Life Expectancy (h)
9BD12SA6	12	5.0 ~ 13.8	0.30	3.6	4,750	0.29 10.2	300 1.205	44	-20 ~ +70	30,000
9BD12HA6			0.24	2.9	4,400	0.27 9.5	230 0.924	42		40,000
9BD12FA6			0.20	2.4	4,050	0.25 8.8	200 0.803	40		30,000
9BD24SA6	24	10.0 ~ 27.6	0.14	3.4	4,750	0.29 10.2	300 1.205	44		30,000
9BD24HA6			0.12	2.9	4,400	0.27 9.5	230 0.924	42		40,000
9BD24FA6			0.10	2.4	4,050	0.25 8.8	200 0.803	40		30,000

### Air Flow and Static Pressure Characteristics

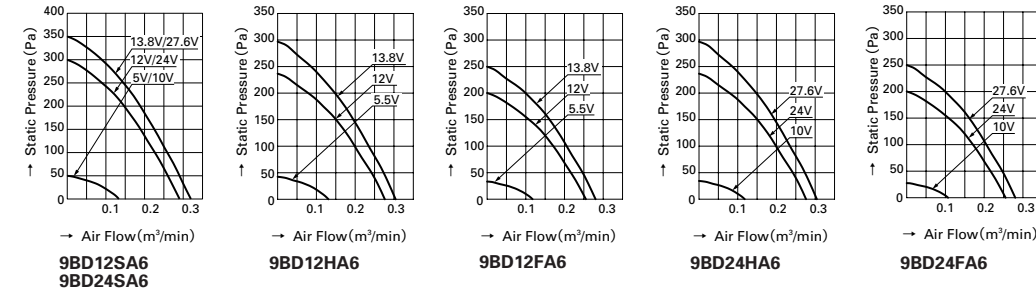

76mm

### 25mm thick Specifications

Model No.	Rated Voltage (V)	Operating Voltage Range (V)	Rated Current (A)	Rated Input (W)	Rated Speed (min <sup>-1</sup> )	Air Flow (m <sup>3</sup> /min) (CFM)	Static Pressure (Pa) (inchH <sub>2</sub> O)	Noise (dB [A])	Operating Temperature Range (°C)	Life Expectancy (h)
109BD12GA4	12	7.2 ~ 13.8	0.33	4.0	4,500	0.34 12.0	178 0.715	48	-20 ~ +60	40,000
109BD12HA4			0.23	2.8	3,800	0.29 10.2	119 0.478	43		
109BD12MA4			0.18	2.2	3,400	0.25 8.8	85 0.341	39		
109BD24GA4	24	12 ~ 27.6	0.19	4.6	4,500	0.34 12.0	178 0.715	48		
109BD24HA4			0.12	2.9	3,800	0.29 10.2	119 0.478	43		
109BD24MA4			0.09	2.2	3,400	0.25 8.8	85 0.341	39		

### Air Flow and Static Pressure Characteristics

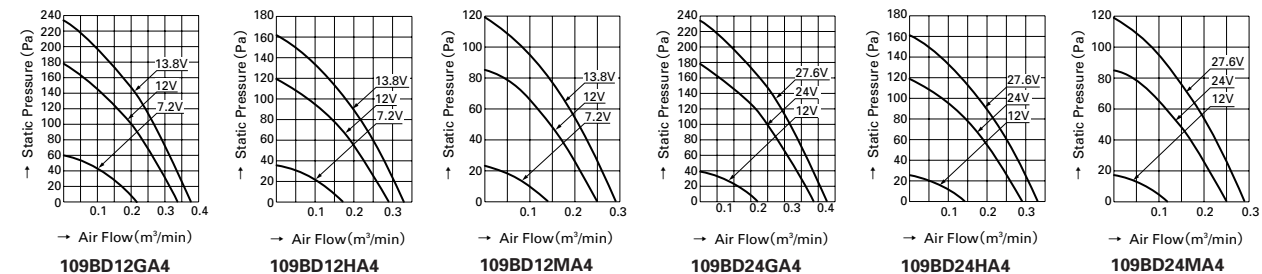

**Dimensions (unit : mm)**

20mm thick

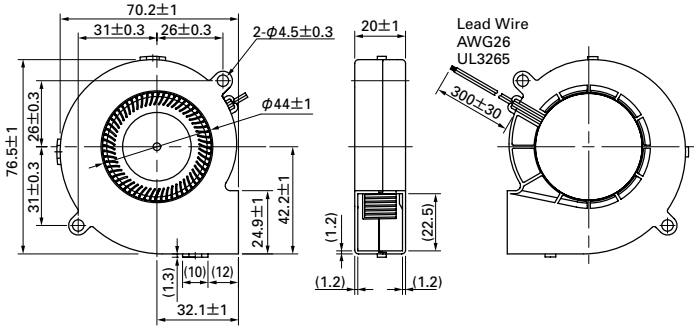

25mm thick

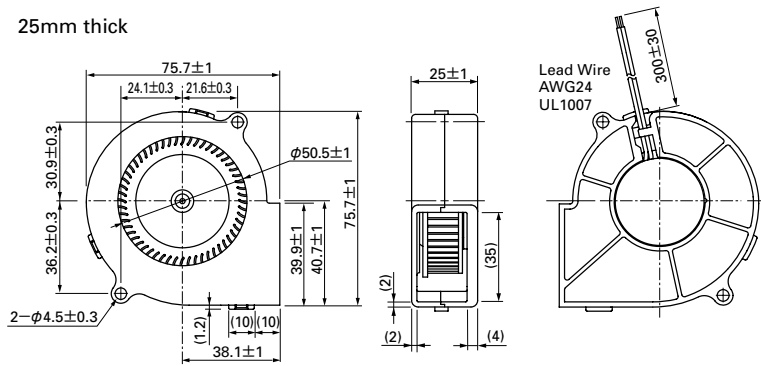

Blowers

76mm





Dimensions (unit : mm)

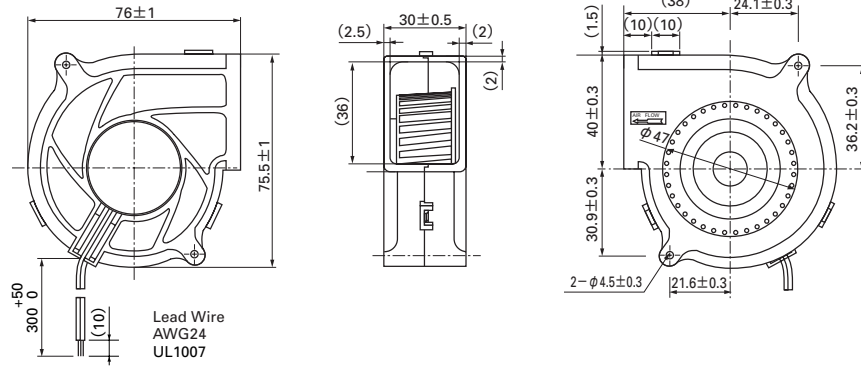

Blowers

76mm

# Blower

## 94mm San Ace B94



### General specifications

- Material ..... Frame, impeller : Plastics
- Life Expectancy ..... Varies for each model (Survival rate: 90% at 60°C, rated voltage, and continuously run in a free air state)
- Motor Protection System ..... Current blocking function (with reverse polarity protection)
- Dielectric Strength ..... 50/60 Hz, 500VAC, 1 minute (between lead conductor and frame)
- Noise Measurement Method ..... Measured at 1m from the air inlet
- Operating Temperature Range ..... Varies for each model (Non-condensing)
- Lead Wire ..... ⊕red, ⊖black
- Mass ..... 135g

Blowers

### 30mm thick Specifications

Model No.	Rated Voltage (V)	Operating Voltage Range (V)	Rated Current (A)	Rated Input (W)	Rated Speed (min <sup>-1</sup> )	Air Flow (m <sup>3</sup> /min) (CFM)	Static Pressure (Pa) (inchH <sub>2</sub> O)	Noise (dB [A])	Operating Temperature Range (°C)	Life Expectancy (h)
<b>109BE12GA2</b>	12	7.2~13.8	0.65	7.8	3,900	0.67 23.7	282 1.133	54	-20 ~ +60	40,000
<b>109BE12HA2</b>			0.42	5.1	3,300	0.57 20.1	194 0.779	49		
<b>109BE12MA2</b>			0.29	3.5	2,700	0.45 15.9	125 0.502	44		
<b>109BE24GA2</b>	24	12 ~ 27.6	0.33	8.0	3,900	0.67 23.7	282 1.133	54		
<b>109BE24HA2</b>			0.26	6.3	3,300	0.57 20.1	194 0.779	49		
<b>109BE24MA2</b>			0.15	3.6	2,700	0.45 15.9	125 0.502	44		

### Air Flow and Static Pressure Characteristics

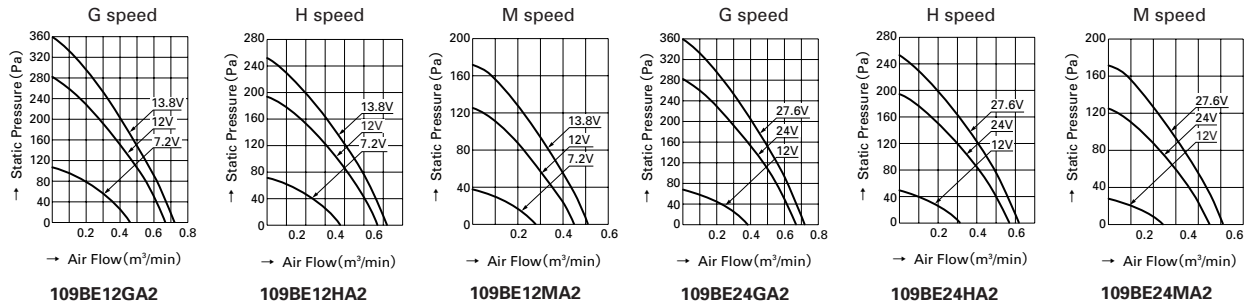

94mm

Dimensions (unit : mm)

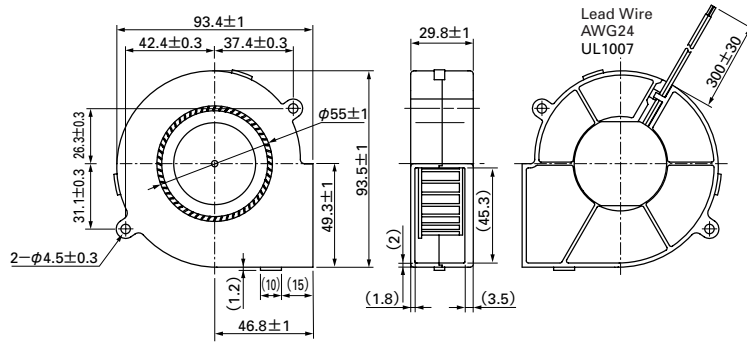

Blowers

94mm

# Blower

# 97mm

## San Ace B97



"San Ace" B97 High Air Flow Type

### General specifications

- Material ..... Frame, impeller : Plastics
- Life Expectancy ..... Varies for each model (Survival rate: 90% at 60°C, rated voltage, and continuously run in a free air state)
- Motor Protection System ..... Current blocking function (with reverse polarity protection)
- Dielectric Strength ..... 50/60 Hz, 500VAC, 1 minute (between lead conductor and frame)
- Noise Measurement Method ..... Measured at 1m from the air inlet
- Operating Temperature Range ..... Varies for each model (Non-condensing)
- Lead Wire ..... ⊕red, ⊖black
- Mass ..... 170g

Blowers

## 33mm thick Specifications

Model No.	Rated Voltage (V)	Operating Voltage Range (V)	Rated Current (A)	Rated Input (W)	Rated Speed (min <sup>-1</sup> )	Air Flow (m <sup>3</sup> /min) (CFM)	Static Pressure (Pa) (inchH <sub>2</sub> O)	Noise (dB [A])	Operating Temperature Range (°C)	Life Expectancy (h)
<b>9BAM12GA2</b>	12	8.4~13.2	1.85	22.2	5,800	1.37 48.4	760 3.052	62	-20 ~ +60	40,000
<b>9BAM12SA2</b>			1.45	17.4	5,300	1.25 44.2	610 2.450	60		
<b>9BAM12HA2</b>			1.20	14.4	4,700	1.10 38.9	490 1.968	58		
<b>9BAM12FA2</b>			0.98	11.8	4,300	1.00 35.3	410 1.647	56		
<b>9BAM24GA2</b>	24	12.0~26.4	0.90	21.6	5,800	1.37 48.4	760 3.052	62		
<b>9BAM24SA2</b>		0.71	17.0	5,300	1.25 44.2	610 2.450	60			
<b>9BAM24HA2</b>		0.60	14.4	4,700	1.10 38.9	490 1.968	58			
<b>9BAM24FA2</b>		0.49	11.8	4,300	1.00 35.3	410 1.647	56			

### Air Flow and Static Pressure Characteristics

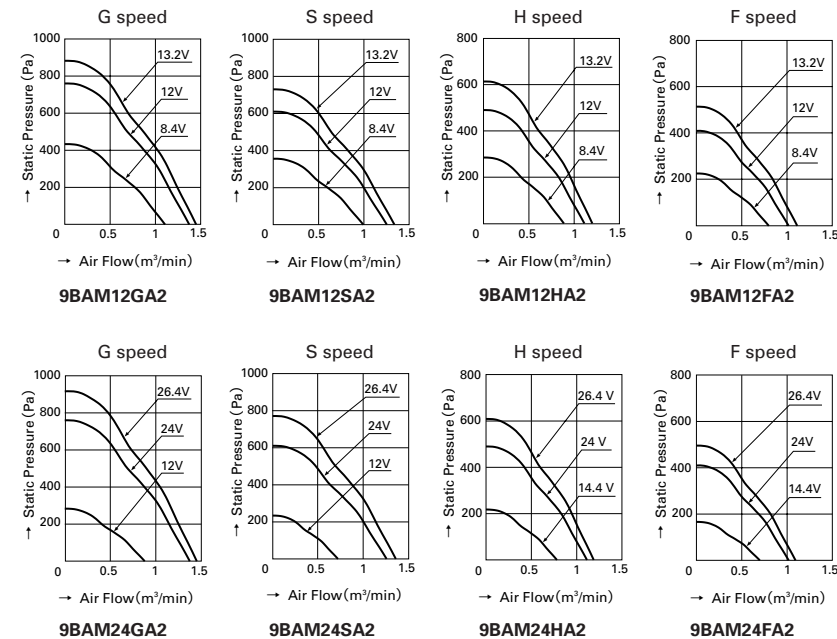

97mm



# Blower

# 97mm San Ace B97



### General specifications

- Material ..... Frame, impeller : Plastics
- Life Expectancy ..... Varies for each model (Survival rate: 90% at 60°C, rated voltage, and continuously run in a free air state)
- Motor Protection System ..... Current blocking function (with reverse polarity protection)
- Dielectric Strength ..... 50/60 Hz, 500VAC, 1 minute (between lead conductor and frame)
- Noise Measurement Method ..... Measured at 1m from the air inlet
- Operating Temperature Range ..... Varies for each model (Non-condensing)
- Lead Wire ..... ⊕red, ⊖black
- Mass ..... 160g

Blowers

## 33mm thick Specifications

Model No.	Rated Voltage (V)	Operating Voltage Range (V)	Rated Current (A)	Rated Input (W)	Rated Speed (min <sup>-1</sup> )	Air Flow (m <sup>3</sup> /min) (CFM)	Static Pressure (Pa) (inchH <sub>2</sub> O)	Noise (dB [A])	Operating Temperature Range (°C)	Life Expectancy (h)
<b>109BM12GA2</b>	12	7.2~13.8	0.68	8.2	3700	0.76 26.9	281 1.129	52	-20 ~+60	40,000
<b>109BM12HA2</b>			0.42	5.1	3200	0.67 23.7	204 0.819	49		
<b>109BM12MA2</b>			0.30	3.6	2600	0.51 18.0	119 0.478	44		
<b>109BM24GA2</b>	24	12 ~27.6	0.34	8.2	3700	0.76 26.9	281 1.129	52		
<b>109BM24HA2</b>			0.26	6.3	3200	0.67 23.7	204 0.819	49		
<b>109BM24MA2</b>			0.15	3.6	2600	0.51 18.0	119 0.478	44		

### Air Flow and Static Pressure Characteristics

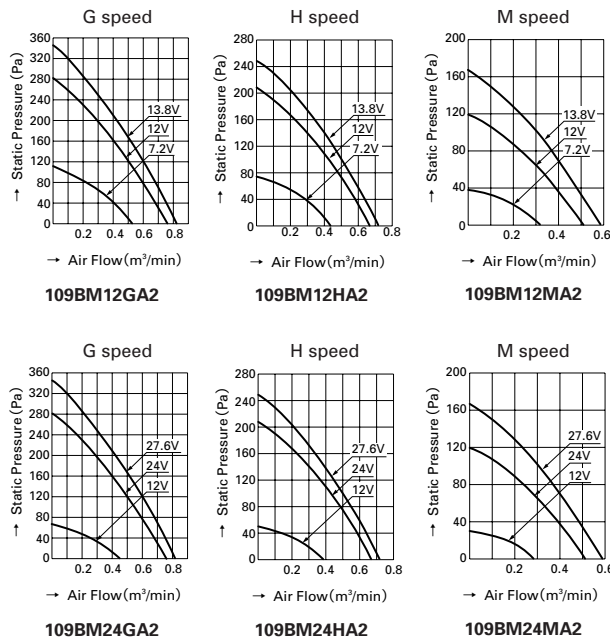

97mm

Dimensions (unit : mm)

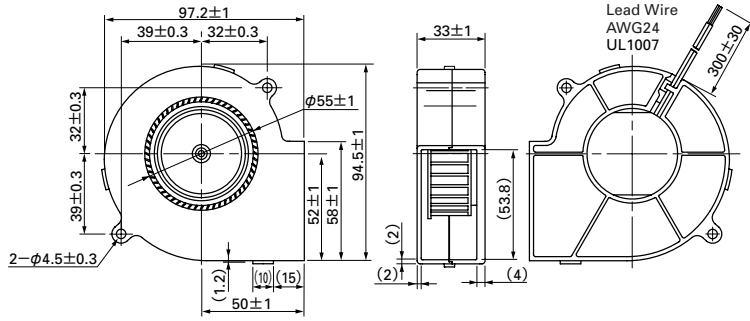

Blowers

97mm

# Blower

# 120mm San Ace B120



### General specifications

- Material ..... Frame, impeller : Plastics
- Life Expectancy ..... Varies for each model (Survival rate: 90% at 60°C, rated voltage, and continuously run in a free air state)
- Motor Protection System ..... Current blocking function (with reverse polarity protection)
- Dielectric Strength ..... 50/60 Hz, 500VAC, 1 minute (between lead conductor and frame)
- Noise Measurement Method ..... Measured at 1m from the air inlet
- Operating Temperature Range ..... Varies for each model (Non-condensing)
- Lead Wire ..... H speed ⊕red, ⊖black  
M speed ⊕red, ⊖black or blue
- Mass ..... 270g

Blowers

## 32mm thick Specifications

Model No.	Rated Voltage (V)	Operating Voltage Range (V)	Rated Current (A)	Rated Input (W)	Rated Speed (min <sup>-1</sup> )	Air Flow (m <sup>3</sup> /min) (CFM)	Static Pressure (Pa) (inchH <sub>2</sub> O)	Noise (dB [A])	Operating Temperature Range (°C)	Life Expectancy (h)
<b>109BF12HA2</b>	12	10.2~13.8	0.6	7.2	2,400	0.78 27.5	175.4 0.704	52	-10 ~ +60	40,000
<b>109BF12MA2</b>			0.32	3.84	1,900	0.61 21.5	109.8 0.441	44		
<b>109BF24HA2</b>	24	20.4~27.6	0.3	7.2	2,400	0.78 27.5	175.4 0.704	52		
<b>109BF24MA2</b>			0.16	3.84	1,900	0.61 21.5	109.8 0.441	44		

### Air Flow and Static Pressure Characteristics

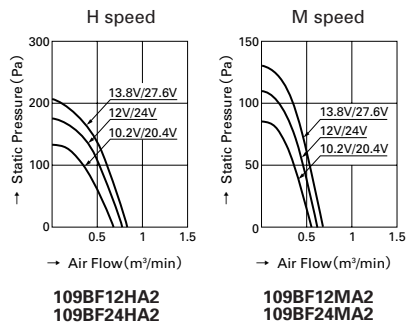

120mm





# Blower

# 127mm San Ace B127



### General specifications

- Material ..... Frame, impeller : Plastics
- Life Expectancy ..... Varies for each model (Survival rate: 90% at 60°C, rated voltage, and continuously run in a free air state)
- Motor Protection System ..... Current blocking function (with reverse polarity protection)
- Dielectric Strength ..... 50/60 Hz, 500VAC, 1 minute (between lead conductor and frame)
- Noise Measurement Method ..... Measured at 1m from the air inlet
- Operating Temperature Range ..... Varies for each model (Non-condensing)
- Lead Wire ..... H speed ⊕red, ⊖black  
M speed ⊕red, ⊖black or blue
- Mass ..... 290g

Blowers

## 32mm thick Specifications

Model No.	Rated Voltage (V)	Operating Voltage Range (V)	Rated Current (A)	Rated Input (W)	Rated Speed (min <sup>-1</sup> )	Air Flow (m <sup>3</sup> /min) (CFM)	Static Pressure (Pa) (inchH <sub>2</sub> O)	Noise (dB [A])	Operating Temperature Range (°C)	Life Expectancy (h)
<b>109BJ12HA2</b>	12	10.2~13.8	0.52	6.24	2,400	0.78 27.5	205.8 0.826	46	-10 ~ +70	40,000
<b>109BJ12MA2</b>			0.29	3.48	1,900	0.61 21.5	109.8 0.441	40		
<b>109BJ24HA2</b>	24	20.4~27.6	0.26	6.24	2,400	0.78 27.5	205.8 0.826	46	-10 ~ +60	
<b>109BJ24MA2</b>			0.15	3.6	1,900	0.61 21.5	109.8 0.441	40		

### Air Flow and Static Pressure Characteristics

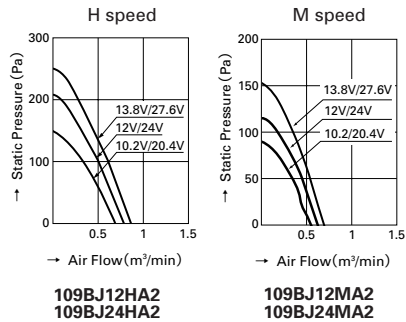

127mm

Dimensions (unit : mm)

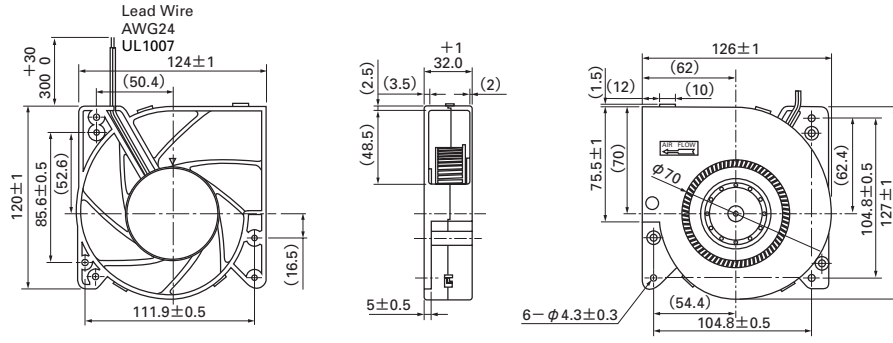

Blowers

127mm

# Blower

# 150mm San Ace B150



### General specifications

- Material ..... Frame, impeller : Plastics
- Life Expectancy ..... Varies for each model (Survival rate: 90% at 60°C, rated voltage, and continuously run in a free air state)
- Motor Protection System ..... Current blocking function (with reverse polarity protection)
- Dielectric Strength ..... 50/60 Hz, 500VAC, 1 minute (between lead conductor and frame)
- Noise Measurement Method ..... Measured at 1m from the air inlet
- Operating Temperature Range ..... Varies for each model (Non-condensing)
- Lead Wire ..... ⊕red, ⊖black
- Mass ..... 380g

Blowers

## 40mm thick Specifications

Model No.	Rated Voltage (V)	Operating Voltage Range (V)	Rated Current (A)	Rated Input (W)	Rated Speed (min <sup>-1</sup> )	Air Flow (m <sup>3</sup> /min) (CFM)	Static Pressure (Pa) (inchH <sub>2</sub> O)	Noise (dB [A])	Operating Temperature Range (°C)	Life Expectancy (h)
<b>9BN12HA1</b>	12	8.4~13.8	1.6	19.2	2,700	2.0 70.7	430 1.727	56	-20 ~ +70	40,000
<b>9BN12FA1</b>			1.1	13.2	2,200	1.65 58.3	270 1.084	51		
<b>9BN24HA1</b>	24	16.8~27.6	0.74	17.8	2,700	2.0 70.7	430 1.727	56		
<b>9BN24FA1</b>			0.54	13.0	2,200	1.65 58.3	270 1.084	51		

### Air Flow and Static Pressure Characteristics

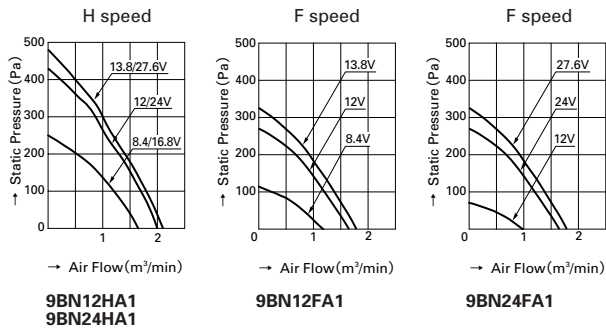

150mm



# Blower

# 160mm San Ace B160



### General specifications

- Material ..... Frame, impeller : Plastics
- Life Expectancy ..... Varies for each model (Survival rate: 90% at 60°C, rated voltage, and continuously run in a free air state)
- Motor Protection System ..... Current blocking function (with reverse polarity protection)
- Dielectric Strength ..... 50/60 Hz, 500VAC, 1 minute (between lead conductor and frame)
- Noise Measurement Method ..... Measured at 1m from the air inlet
- Operating Temperature Range ..... Varies for each model (Non-condensing)
- Lead Wire ..... H speed ⊕red, ⊖black  
M speed ⊕red, ⊖black or blue
- Mass ..... 580g

Blowers

## 40mm thick Specifications

Model No.	Rated Voltage (V)	Operating Voltage Range (V)	Rated Current (A)	Rated Input (W)	Rated Speed (min <sup>-1</sup> )	Air Flow (m <sup>3</sup> /min) (CFM)	Static Pressure (Pa) (inchH <sub>2</sub> O)	Noise (dB [A])	Operating Temperature Range (°C)	Life Expectancy (h)
<b>109BG12HA1</b>	12	10.2~13.8	1.3	15.6	2,300	1.62 57.2	313.6 1.259	55	-10 ~ +60	40,000
<b>109BG12MA1</b>			0.64	7.68	1,800	1.26 44.5	156.8 0.629	50		
<b>109BG24HA1</b>	24	20.4~27.6	0.62	14.88	2,300	1.62 57.2	313.6 1.259	55		
<b>109BG24MA1</b>			0.31	7.44	1,800	1.26 44.5	156.8 0.629	50		

### Air Flow and Static Pressure Characteristics

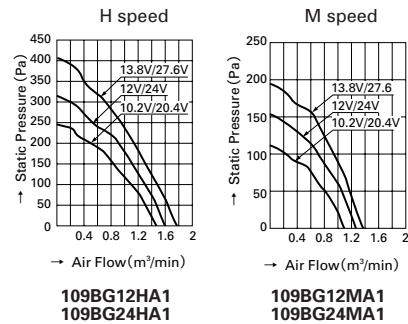

160mm

Dimensions (unit : mm)

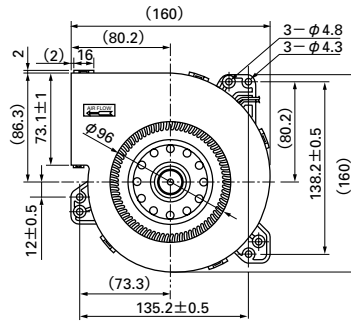
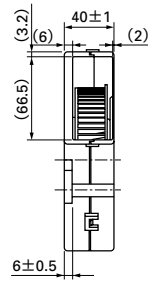
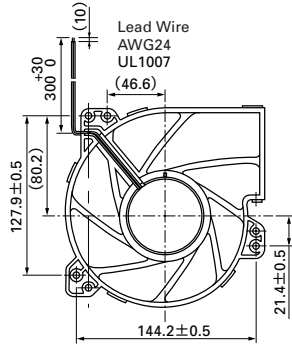

Blowers

160mm





# DC FAN

# Centrifugal Fans

## Domain diagram

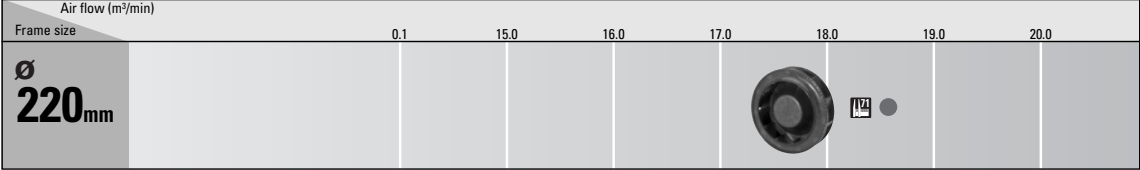

**Conversion table**

- 1m<sup>3</sup>/min=35.31(CFM)
- 1CFM=0.0283m<sup>3</sup>/min
- 1m<sup>3</sup>/min=16.67 l/sec
- 1CFM=0.472 l/sec
- 1 l/sec=0.06m<sup>3</sup>/min

Centrifugal Fans

200mm

# Centrifugal Fan $\varnothing 220\text{mm}$ San Ace C220

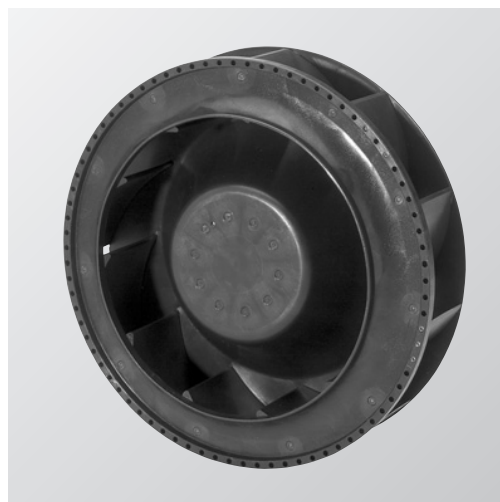

## General specifications

- Material ..... Impeller : Plastic  
Attachment base: Aluminum
- Life Expectancy ..... Varies for each model (Survival rate: 90% at 60°C,  
rated voltage, and continuously run in a free air state)
- Motor Protection System ..... Current cut function (with reverse polarity protection)
- Dielectric Strength ..... 50/60 Hz, 500VAC, 1 minute (between Lead conductor and Attachment base)
- Noise Measurement Method ..... Measured at 1m from the air inlet
- Operating Temperature Range ..... Varies for each model (Non-condensing)
- Lead Wire .....  $\oplus$ red,  $\ominus$ black
- Mass ..... 1,300g

## 71 mm thick Specifications

Model No.	Rated Voltage (V)	Operating Voltage Range (V)	Rated Current (A)	Rated Input (W)	Rated Speed (min <sup>-1</sup> )	Air Flow (m <sup>3</sup> /min) (CFM)	Static Pressure (Pa) (inchH <sub>2</sub> O)	Noise (dB [A])	Operating Temperature Range (°C)	Life Expectancy (h)
<b>9TR48HA0</b>	48	36~56	2.10	100.8	3,200	18.5 653.7	700 2.81	71	-20 ~ +60	40,000

(Note) Air Flow-Static Pressure Characteristics and Sound Pressure Level were measured with Inlet Ring (See following figure).

## Air Flow and Static Pressure Characteristics

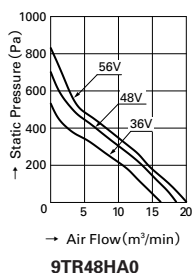

## Dimensions (unit : mm)

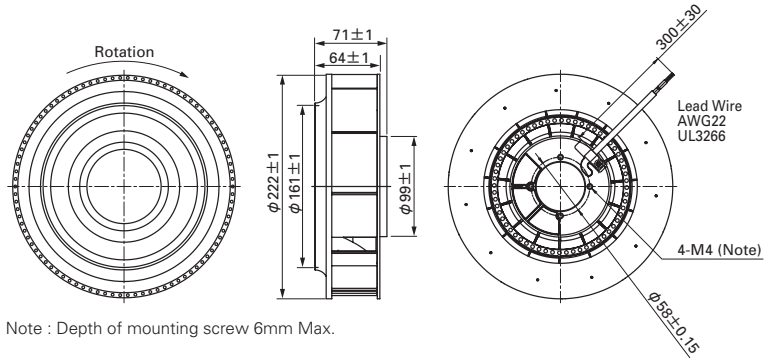

## Reference Dimension of Inlet Ring (unit : mm)

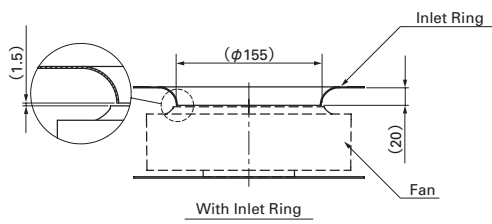

Note : Please contact us if you need further information.



# COOLING SYSTEMS

## CPU Coolers Liquid Cooling Solution Systems

**Performance**

**SAN ACE MC Liquid**  
109-LC1-001

**SAN ACE MC**  
109X9112PT0H016

**SAN ACE MC-HX**  
9H9912G5016

**SAN ACE MC**  
109X9912T0S016  
109X9912S0016

**SAN ACE MC**  
109X9212PT0H016

**SAN ACE MC**  
9G0912PT2E012  
9G0912P2E012

**SAN ACE MC**  
109X9912T0D516

**SAN ACE MC**  
109X7612H1176

**SAN ACE MC**  
109X9412S1016

**SAN ACE MC**  
109X9412G4016

**SAN ACE MC**  
109X9812T0H016  
109X9812H0016

**SAN ACE MC**  
109X9612S5016

**Intel® Pentium® D**

**Intel® Pentium® 4**

**Intel® Pentium® III**

**SAN ACE MC**  
109X7412S4016

**SAN ACE MC**  
109X6512A2016

2002      2003      2004      2005      2006

775-and LGA  
Socket478  
Socket473  
FC-PGA2  
FC-PGA  
Liquid cooling solution system

Intel® Pentium® is a trademark of Intel Corporation.

# CPU Cooler

## For Intel® 775 land-LGA Package CPU Cooler "SAN ACE MC" Thermal Module (Type I) for BTX



### General specifications

Material ..... Frame, Impeller, Duct: Plastics Duct sael: Rubber sponge  
Heatsink: Aluminum (Core: Copper)

Life Expectancy ..... Varies for each model (Survival rate: 90% at 60°C,  
rated voltage, and continuously run in a free air state)

Motor Protection System ..... Current blocking function (with reverse polarity protection)

Dielectric Strength ..... 50/60 Hz, 500VAC, 1 minute (between lead conductor and frame)

Noise Measurement Method ..... Measured at 1m from the air inlet

Operating Temperature Range ..... Varies for each model (Non-condensing)

Lead Wire ..... ⊕ Yellow (Connector: Pin2)  
⊖ Black (Connector: Pin1)  
Ⓢ Sensor Green (Connector: Pin3)  
Ⓢ Control Blue (Connector: Pin4)

Connector ..... Molex P/N 47054-1000 or Wieson 2510C888-001

Contact ..... Molex P/N 5159PBT or Equivalent or Wieson 2511-T1

Mass ..... 970g

### Specifications

Model No.	Rated Voltage (V)	Operating Voltage Range (V)	Rated Current (A)	Rated Speed (min <sup>-1</sup> )	Ψc-a Thermal Resistance (K/W)	Noise (dB [A])	Operating Temperature Range (°C)	Life Expectancy (h)		
9G0912P2E012*	12	10.8~13.2	0.90	4,700	0.260	52	0 ~ +70	40,000		
9G0912PT2E012**				4,700					0.260	52
				2,500					0.300	34

\* PWM Control Function  
\*\* PWM Control Function and Thermally Speed Control

### Control input PWM duty - Fan speed characteristics

9G0912P2E012 [PWM Control Function]

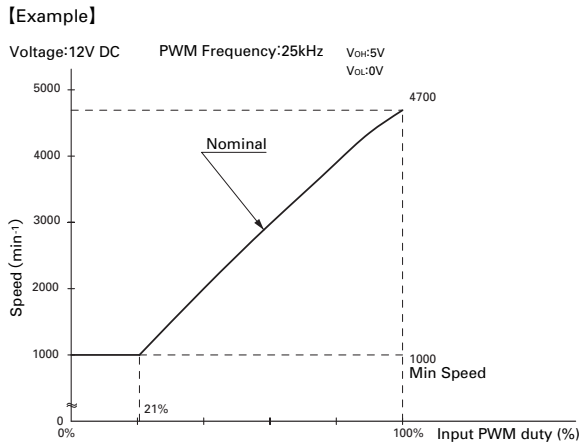

9G0912PT2E012 [PWM Control Function and Thermally Speed Control]

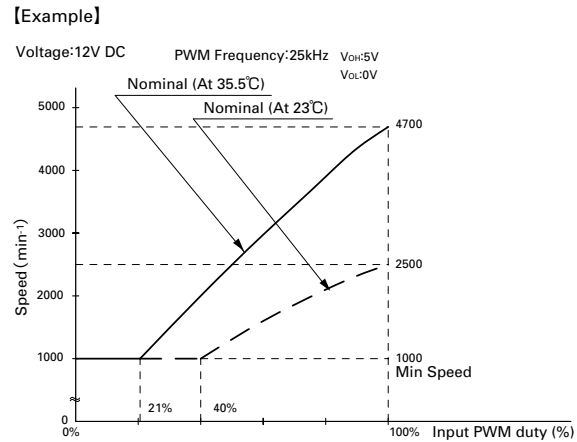

#### Waveform of control input

PWM Signal input : Between blue lead and black lead

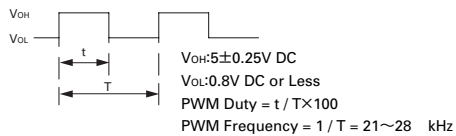

#### Control Current

I Source max.: 5 mA (AT 0V Control Voltage)  
I Sink max.: 5 mA (AT 5V Control Voltage)



# CPU Cooler

## For Intel® 775-land LGA Package CPU Cooler "SAN ACE MC"

### PWM Control Function and Thermally Speed Control

#### General specifications

- Material ..... Frame,impeller:Plastics  
Heatsink:aluminum (Core:copper)
- Life Expectancy .....Varies for each model (Survival rate: 90% at 60°C,  
rated voltage,and continuously run in a free air state)
- Motor Protection System .....Current blocking function (with reverse polarity protection)
- Dielectric Strength .....50/60 Hz, 500VAC, 1 minute (between lead conductor and frame)
- Noise Measurement Method .....Measured at 1m from the air inlet
- Operating Temperature Range .....Varies for each model (Non-condensing)
- Lead Wire .....⊕yellow (connector No.2 side)  
⊖black (connector No.1 side)  
Ⓢensor green (connector No.3)  
Ⓚontrol blue (connector No.4)
- Connector .....Molex P/N 47054-1000 or Wieson 2510C888-001
- Contact .....Molex P/N 5159PBT or Equivalent or Wieson 2511-T1
- Mass .....575g



CPU Coolers  
Liquid Cooling  
Solution System

#### Specifications

Model No.	Rated Voltage (V)	Operating Voltage Range (V)	Rated Current (A)	Rated Speed (min <sup>-1</sup> )	$\theta_{c-a}$ Thermal Resistance (K/W)	Noise (dB [A])	Operating Temperature Range (°C)	Life Expectancy (h)
109X9112PT0H016	12	10.8~13.2	0.31	3,900	0.266	42	0 ~ +70	40,000
				2,300	0.320	27		

#### Control input PWM duty - Fan speed characteristics

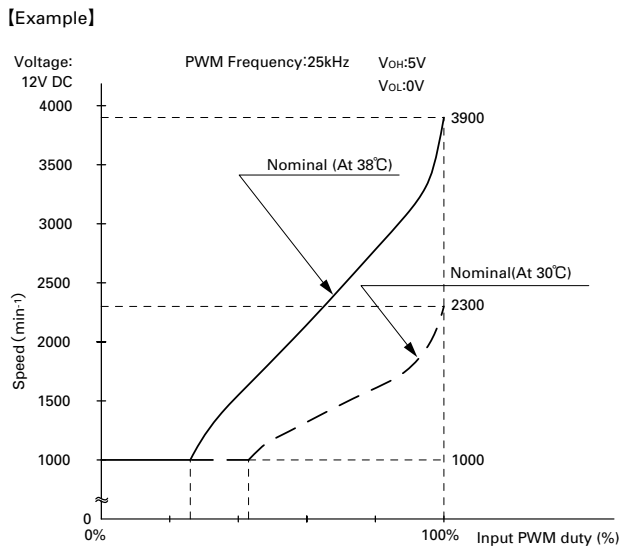

PWM Waveform of control input  
PWM Signal input ; Between blue lead and black lead

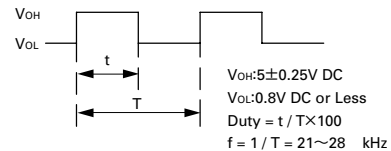

#### Control input Current

- I Source max.: 5 mA (AT 0V Control Voltage)
- I Sink max.: 5 mA (AT 5V Control Voltage)



Dimensions (unit : mm)

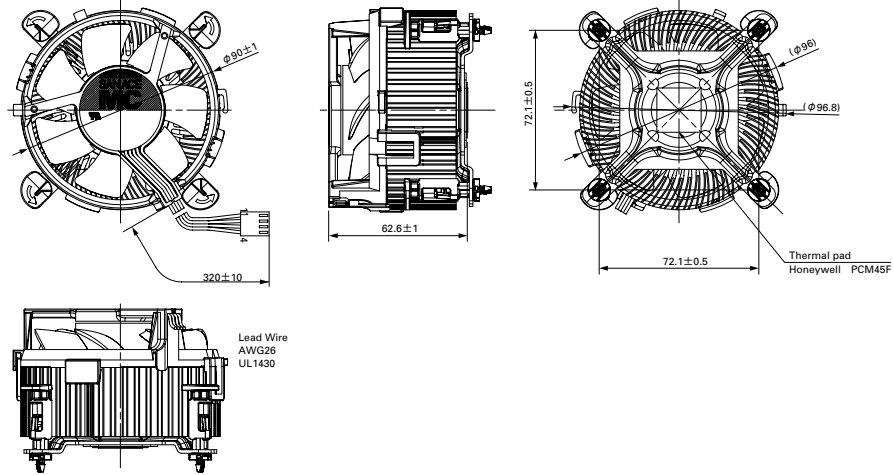

# CPU Cooler

For Intel® Pentium® 4 Processor (775-land LGA Package)  
CPU Cooler "SAN ACE MC"



## PWM Control Function and Thermally Speed Control General specifications

- Material ..... Frame, impeller: Plastics  
Heatsink: aluminum (Core: copper)
- Life Expectancy ..... Varies for each model (Survival rate: 90% at 60°C,  
rated voltage, and continuously run in a free air state)
- Motor Protection System ..... Current blocking function (with reverse polarity protection)
- Dielectric Strength ..... 50/60 Hz, 500VAC, 1 minute (between lead conductor and frame)
- Noise Measurement Method ..... Measured at 1m from the air inlet
- Operating Temperature Range ..... Varies for each model (Non-condensing)
- Lead Wire ..... ⊕yellow (connector No.2 side)  
⊖black (connector No.1 side)  
Ⓢensor green (connector No.3 side)  
Ⓢontrol blue (connector No.4 side)
- Connector ..... Molex P/N 47054-1000 or Wieson 2510C888-001
- Contact ..... Molex P/N 5159PBT or Equivalent or Wieson 2511-T1
- Mass ..... 490g

CPU Coolers  
Liquid Cooling  
Solution System

## Specifications

Model No.	Rated Voltage (V)	Operating Voltage Range (V)	Rated Current (A)	Rated Speed (min <sup>-1</sup> )	θ c-a Thermal Resistance (K/W)	Noise (dB [A])	Operating Temperature Range (°C)	Life Expectancy (h)
109X9212PT0H016	12	10.8~13.2	0.28	3,650	0.276	42	0 ~ +70	40,000
				2,200	0.340	28		

775-land LGA

## Control input PWM duty - Fan speed characteristics

[EXAMPLE]

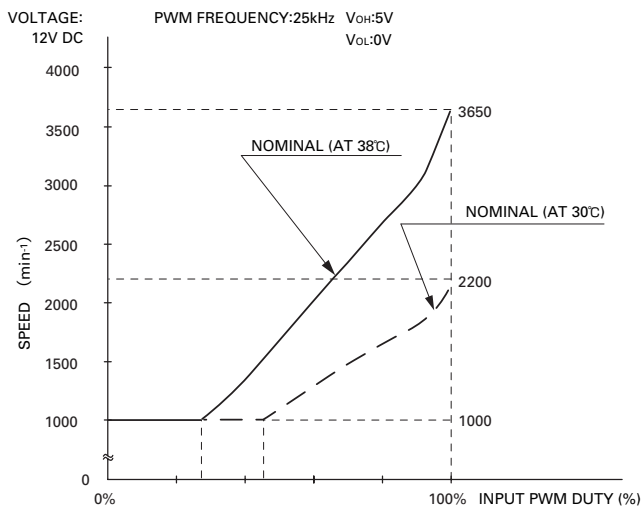

PWM WAVEFORM OF CONTROL INPUT  
PWM SIGNAL INPUT: BETWEEN BLUE LEAD AND BLACK LEAD

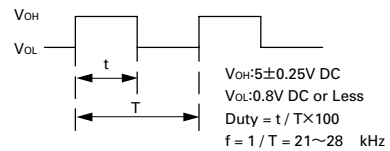

CONTROL INPUT CURRENT  
I<sub>SOURCE</sub> MAX.: 5 mA (AT 0V CONTROL VOLTAGE)  
I<sub>SINK</sub> MAX.: 5 mA (AT 5V CONTROL VOLTAGE)

**Dimensions (unit : mm)**

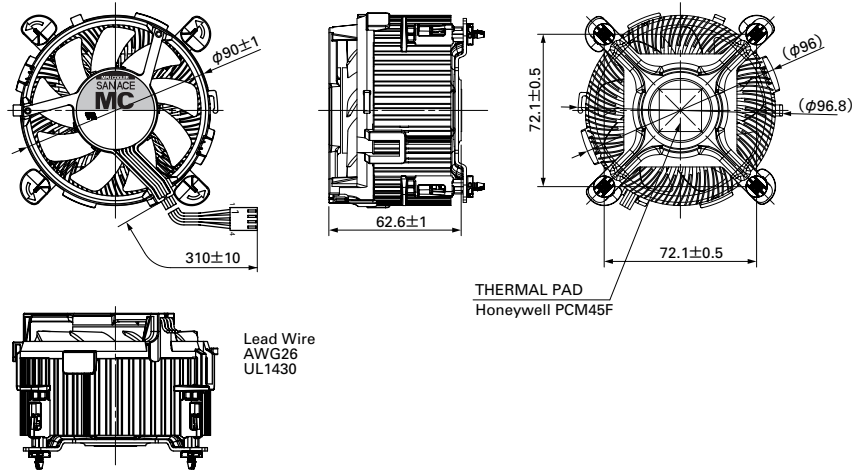

# CPU Cooler

## For Intel® Pentium® 4 Processor (Socket 478) CPU Cooler "SAN ACE MC"

### General specifications

Material	Frame,impeller:resin mold Heatsink:aluminum (Core:copper)
Life Expectancy	Varies for each model (Survival rate: 90% at 60°C, rated voltage,and continuously run in a free air state)
Motor Protection System	Current blocking function (with reverse polarity protection)
Dielectric Strength	50/60 Hz, 500VAC, 1 minute (between lead conductor and frame)
Noise Measurement Method	Measured at 1m from the air inlet
Operating Temperature Range	Varies for each model (Non-condensing)
Lead Wire	⊕yellow (connector No.2 side) ⊖black (connector No.1 side) sensor green (connector No.3 side)
Connector	Molex 22-01-3037 : P/N2695-03RP
Contact	Molex P/N5159PBT or 2759T-equivalent
Mass	450g



### Specifications

Model No.	Rated Voltage (V)	Operating Voltage Range (V)	Rated Current (A)	Rated Rotating Speed (min <sup>-1</sup> )	$\theta_{c-a}$ Thermal Resistance (K/W)	Noise (dB [A])	Operating Temperature Range (°C)	Life Expectancy (h)
109X9912T0D516	12	9~13.8	0.44	5,200	0.28	44	0 ~ +70	40,000
				2,570	0.385	26		

Dimensions (unit : mm)

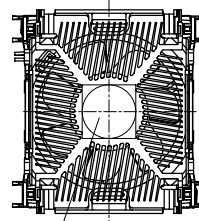
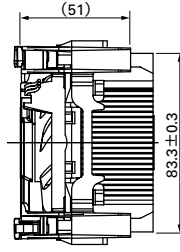
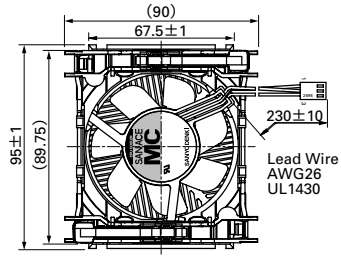

Thermal Pad  
Honeywell PCM45F

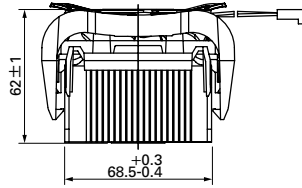

# CPU Cooler

## For Intel® Pentium® 4 Processor 3.06GHz (Socket 478)

### General specifications

Material	Frame, impeller: Plastics Heatsink: aluminum (Core: copper)
Life Expectancy	Varies for each model (Survival rate: 90% at 60°C, rated voltage, and continuously run in a free air state)
Motor Protection System	Current blocking function (with reverse polarity protection)
Dielectric Strength	50/60 Hz, 500VAC, 1 minute (between lead conductor and frame)
Noise Measurement Method	Measured at 1m from the air inlet
Operating Temperature Range	Varies for each model (Non-condensing)
Lead Wire	⊕ yellow (connector No.2 side) ⊖ black (connector No.1 side) Ⓢ (sensor) green (connector No.3 side)
Connector	Molex 22-01-3037 : P/N2695-03RP
Contact	Molex P/N5159PBT or equivalent
Mass	450g



### Specifications

Model No.	Rated Voltage (V)	Operating Voltage Range (V)	Rated Current (A)	Rated Rotating Speed (min <sup>-1</sup> )	$\theta_{c-a}$ Thermal Resistance (K/W)	Noise (dB [A])	Operating Temperature Range (°C)	Life Expectancy (h)
109X9912T0S016	12	9~13.8	0.48	5,400	0.295	45	0 ~ +70	40,000
				2,610	0.42	28		
109X9912S0016				5,400	0.295	45		

**Dimensions (unit : mm)**

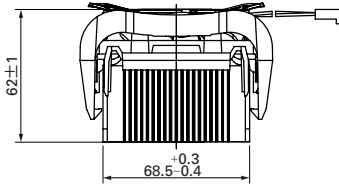
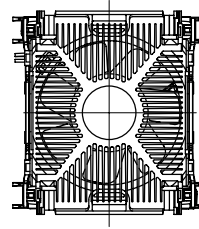
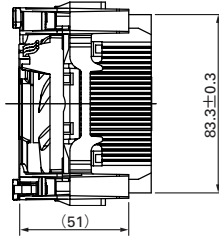
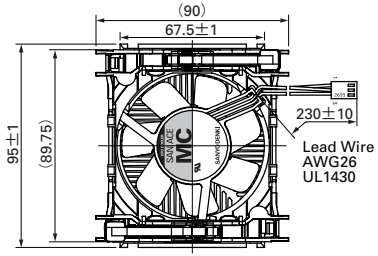





**Dimensions (unit : mm)**

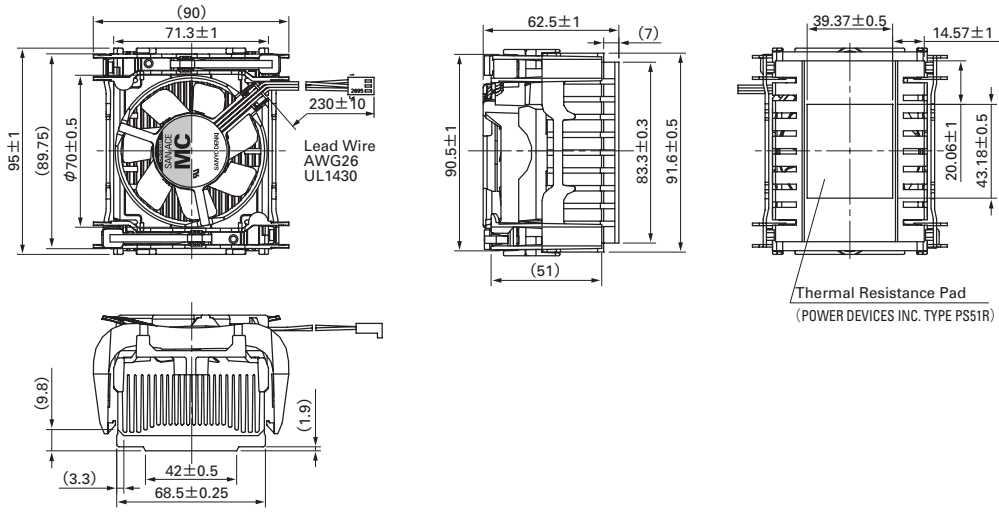

# CPU Cooler

## For Intel® Pentium® 4 Processor 2.0GHz (Socket 478) CPU Cooler "SAN ACE MC" for 1U server

### General specifications

Material .....Frame, impeller : Plastics Heat sink : copper  
 Life Expectancy .....Varies for each model (Survival rate: 90% at 60°C,  
 rated voltage,and continuously run in a free air state)  
 Motor Protection System ....Current blocking function (with reverse polarity protection)  
 Dielectric Strength .....50/60 Hz, 500VAC, 1 minute (between lead conductor and frame)  
 Noise Measurement Method ..Measured at 1m from the air inlet  
 Operating Temperature Range ..Varies for each model (Non-condensing)  
 Lead Wire .....⊕yellow (connector No.2 side)  
 ⊖black (connector No.1 side)  
 sensor green (connector No.3 side)  
 Connector .....Molex 22-01-3037 : P/N2695-03RP  
 Contact .....Molex P/N5159PBT or 2759T-equivalent  
 Mounting method.....Use Mounting Clip 109-1011 2pcs.  
 Option(separate order).....Model No.109-1011  
 Mass .....340g

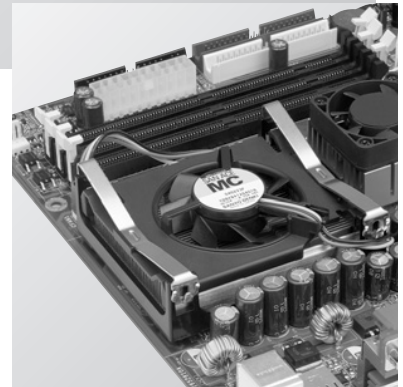

CPU Coolers  
Liquid Cooling  
Solution System

### Specifications

Model No.	Rated Voltage (V)	Operating Voltage Range (V)	Rated Current (A)	Rated Speed (min <sup>-1</sup> )	$\theta_{c-a}$ Thermal Resistance (K/W)	Noise (dB [A])	Operating Temperature Range (°C)	Life Expectancy (h)
<b>109X9412G4016</b>	12	7~13.8	0.07	7,600	0.435	52	0~+70	40,000

Socket478

**Dimensions (unit : mm)**

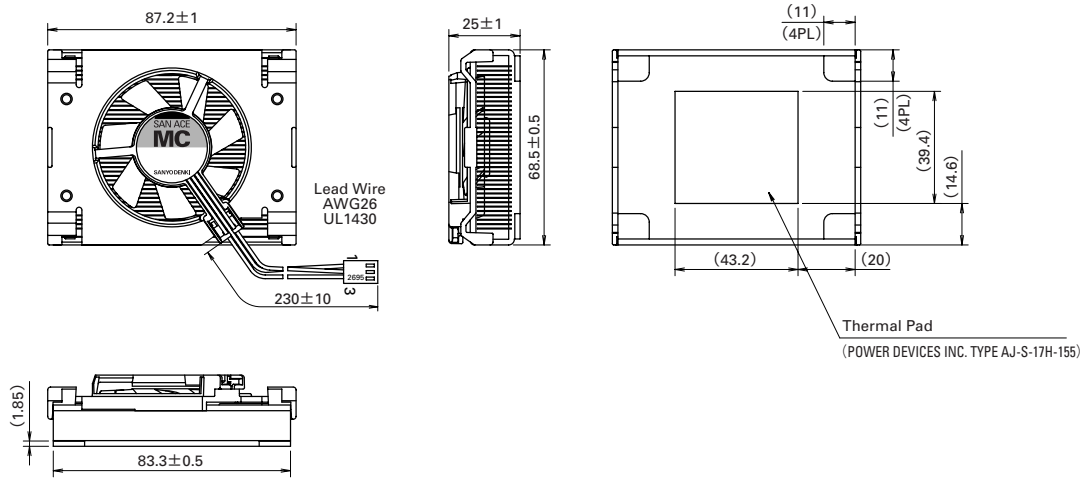

**Mounting Clip**

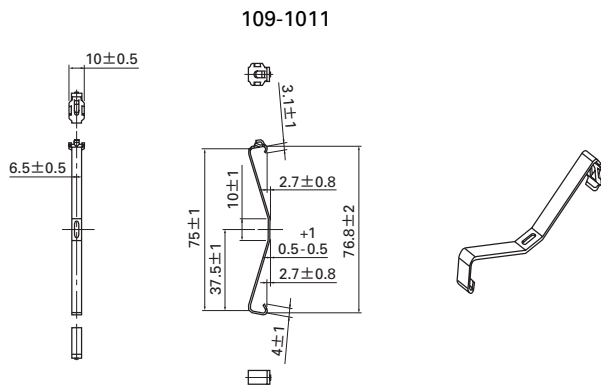

Material : Stainless steel

# CPU Cooler

## For Intel® Pentium® 4 Processor 2.8GHz (Socket 478) CPU Cooler "SAN ACE MC-HX"

### General specifications

Material .....Frame, impeller : Plastics Heat sink : copper  
 Life Expectancy .....Varies for each model (Survival rate: 90% at 60°C,  
 rated voltage,and continuously run in a free air state)  
 Motor Protection System .....Current blocking function (with reverse polarity protection)  
 Dielectric Strength .....50/60 Hz, 500VAC, 1 minute (between lead conductor and frame)  
 Noise Measurement Method .....Measured at 1m from the air inlet  
 Operating Temperature Range .....Varies for each model (Non-condensing)  
 Lead Wire .....⊕yellow (connector No.2 side)  
 .....⊖black (connector No.1 side)  
 .....sensor green (connector No.3 side)  
 Contact .....(Molex)P/N5159PBT or 2759T-equivalent  
 Option(separate order).....Mounting method : Mount using 109-1007 specialized  
 metal fittings(2pcs.)  
 Mass .....410g

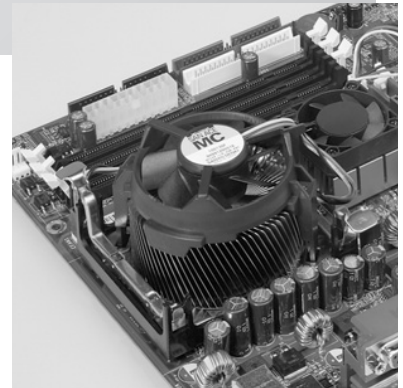

CPU Coolers  
Liquid Cooling  
Solution System

### Specifications

Model No.	Rated Voltage (V)	Operating Voltage Range (V)	Rated Current (A)	Rated Speed (min <sup>-1</sup> )	$\theta_{c-a}$ Thermal Resistance (K/W)	Noise (dB [A])	Operating Temperature Range (°C)	Life Expectancy (h)
9H9912G5516	12	7~13.8	0.23	5,200	0.37	39	0 ~ +70	40,000

Socket478

**Dimensions (unit : mm)**

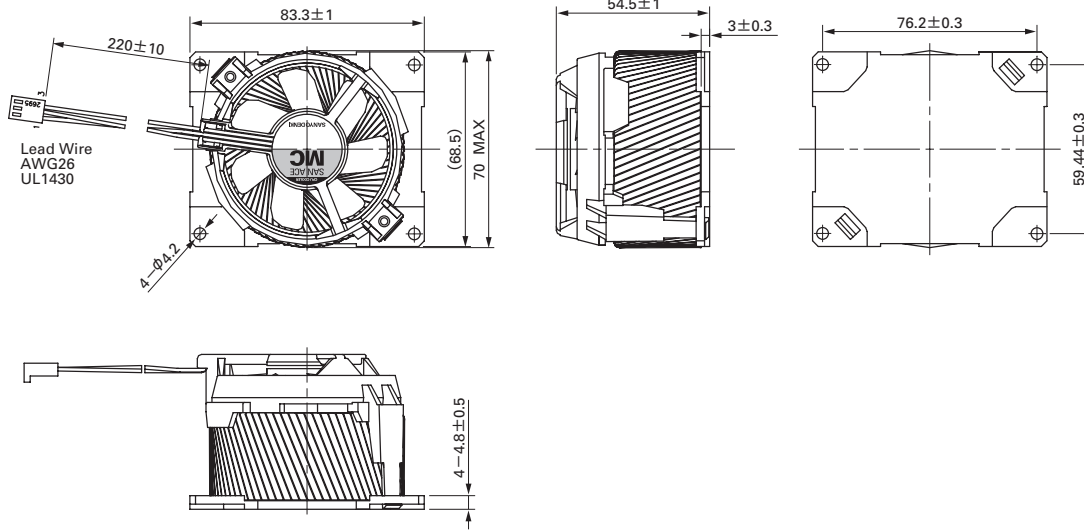

**Mounting Clip**

109-1007

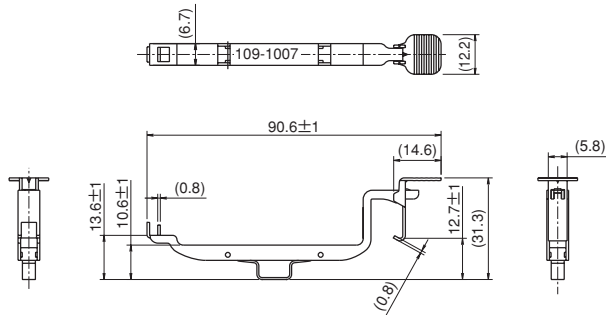

Material : Stainless steel

# CPU Cooler

## For Intel® Pentium® 4 Processor 2.0GHz (Socket 478)

### General specifications

- Material .....Frame, impeller : Plastics  
Heat sink : aluminum base + copper fin
- Life Expectancy .....Varies for each model (Survival rate: 90% at 60°C,  
rated voltage,and continuously run in a free air state)
- Motor Protection System .....Current blocking function (with reverse polarity protection)
- Dielectric Strength .....50/60 Hz, 500VAC, 1 minute (between lead conductor and frame)
- Noise Measurement Method .....Measured at 1m from the air inlet
- Operating Temperature Range .....Varies for each model (Non-condensing)
- Lead Wire .....⊕yellow (connector No.2 side)  
⊖black (connector No.1 side)  
Ⓢ(sensor) green (connector No.3 side)
- Connector .....Molex 22-01-3037 : P/N2695-03RP
- Contact .....Molex P/N5159PBT or 2759T-equivalent
- Mass .....360g
- Option (Separate order) .....Mount using 109-1008 specialized metal fittings (2pcs)

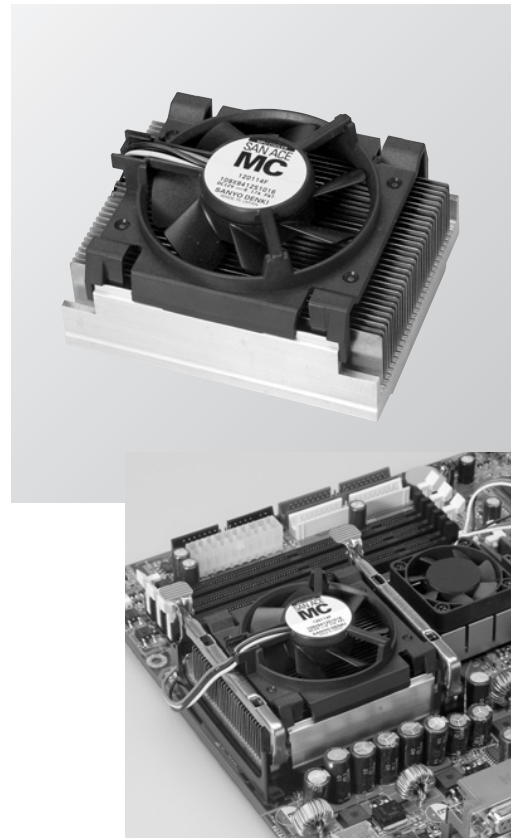

CPU Coolers  
Liquid Cooling  
Solution System

### Specifications

Model No.	Rated Voltage (V)	Operating Voltage Range (V)	Rated Current (A)	Rated Speed (min <sup>-1</sup> )	$\theta_{c-a}$ Thermal Resistance (K/W)	Noise (dB [A])	Operating Temperature Range (°C)	Life Expectancy (h)
<b>109X9412S1016</b>	12	7~13.8	0.17	4,800	0.445	39	0 ~+70	40,000

Socket478

**Dimensions (unit : mm)**

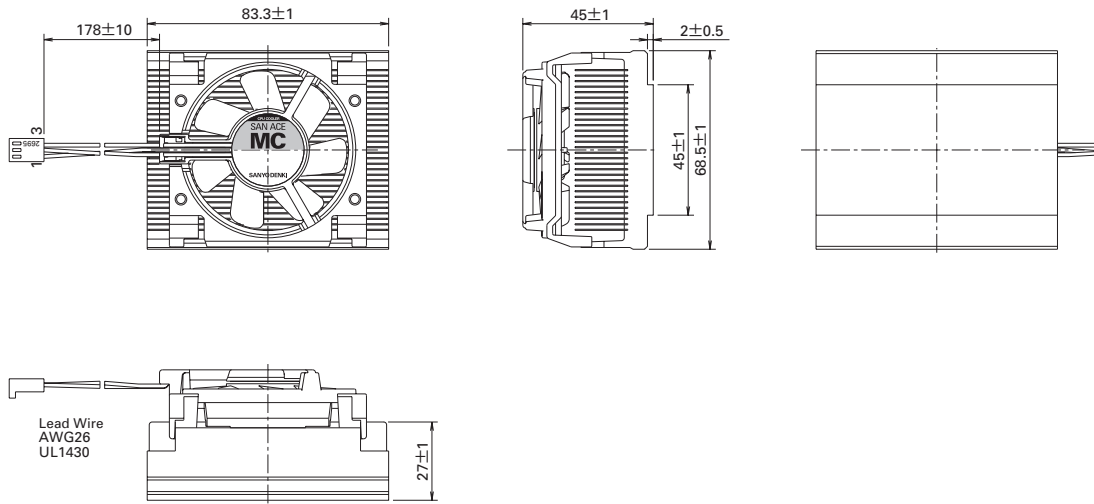

**Installation metal fittings (unit : mm)**

109-1008

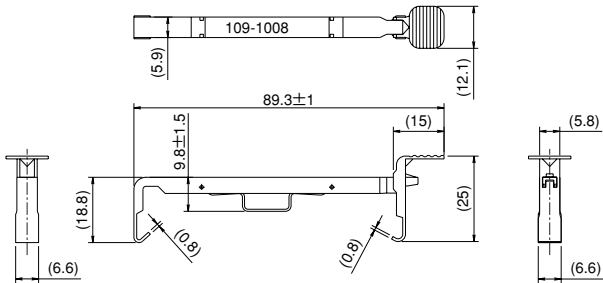

Material : Stainless steel

# CPU Cooler

## For Intel® Pentium® 4 Processor (Socket 423) CPU Cooler "SAN ACE MC-HX"

### General specifications

Material	Frame, impeller : resin mold Heat sink : copper
Life Expectancy	Varies for each model (Survival rate: 90% at 60°C, rated voltage, and continuously run in a free air state)
Motor Protection System	Current blocking function (with reverse polarity protection)
Dielectric Strength	50/60 Hz, 500VAC, 1 minute (between lead conductor and frame)
Noise Measurement Method	Measured at 1m from the air inlet
Operating Temperature Range	Varies for each model (Non-condensing)
Lead Wire	⊕yellow (connector No.2 side) ⊖black (connector No.1 side) sensor green (connector No.3 side)
Connector	Molex 22-01-3037 : P/N2695-03RP
Contact	Molex P/N5159PBT or 2759T-equivalent
Mass	410g



### Specifications

Model No.	Rated Voltage (V)	Operating Voltage Range (V)	Rated Current (A)	Rated Speed (min <sup>-1</sup> )	$\theta_{c-a}$ Thermal Resistance (K/W)	Noise (dB [A])	Operating Temperature Range (°C)	Life Expectancy (h)
9H9912G5016	12	7~13.8	0.07	4,800	1.15	35	0 ~ +70	40,000



Dimensions (unit : mm)

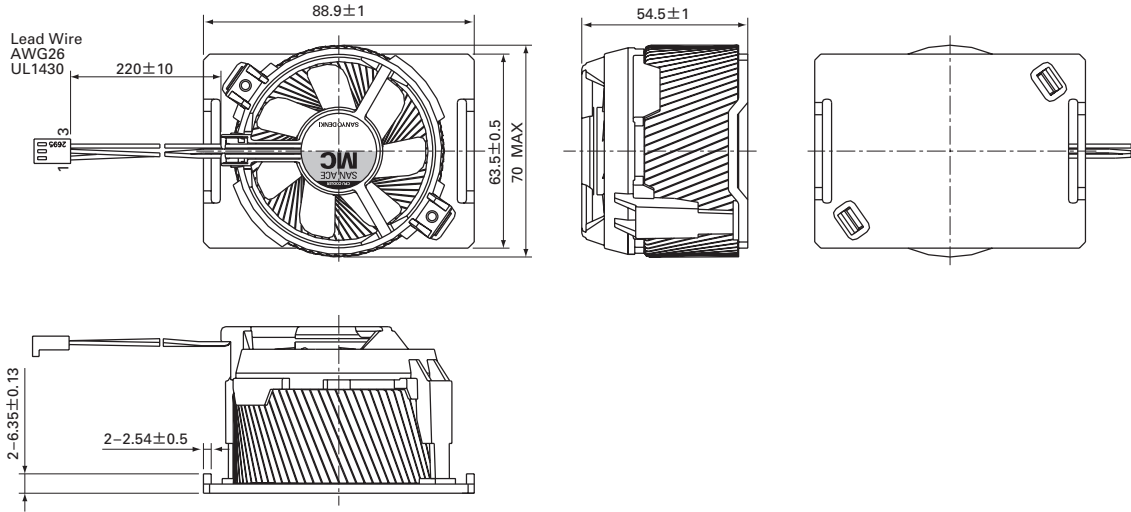

# CPU Cooler

## For Intel® Pentium® 4 Processor 2.0GHz (Socket 423)

### General specifications

Material	Frame, impeller : resin mold Heat sink : aluminum
Life Expectancy	Varies for each model (Survival rate: 90% at 60°C, rated voltage, and continuously run in a free air state)
Motor Protection System	Current blocking function (with reverse polarity protection)
Dielectric Strength	50/60 Hz, 500VAC, 1 minute (between lead conductor and frame)
Noise Measurement Method	Measured at 1m from the air inlet
Operating Temperature Range	Varies for each model (Non-condensing)
Lead Wire	⊕yellow (connector No.2 side) ⊖black (connector No.1 side) Ⓢ(sensor) green (connector No.3 side)
Connector	Molex 22-01-3037 : P/N2695-03RP
Contact	Molex P/N5159PBT or 2759T-equivalent
Mass	265g



### Specifications

Model No.	Rated Voltage (V)	Operating Voltage Range (V)	Rated Current (A)	Rated Speed (min <sup>-1</sup> )	$\theta_{c-a}$ Thermal Resistance (K/W)	Noise (dB [A])	Operating Temperature Range (°C)	Life Expectancy (h)
<b>109X9612S5016</b>	12	9~13.8	0.23	5,000	0.44	40	0 ~ +70	40,000

**Dimensions (unit : mm)**

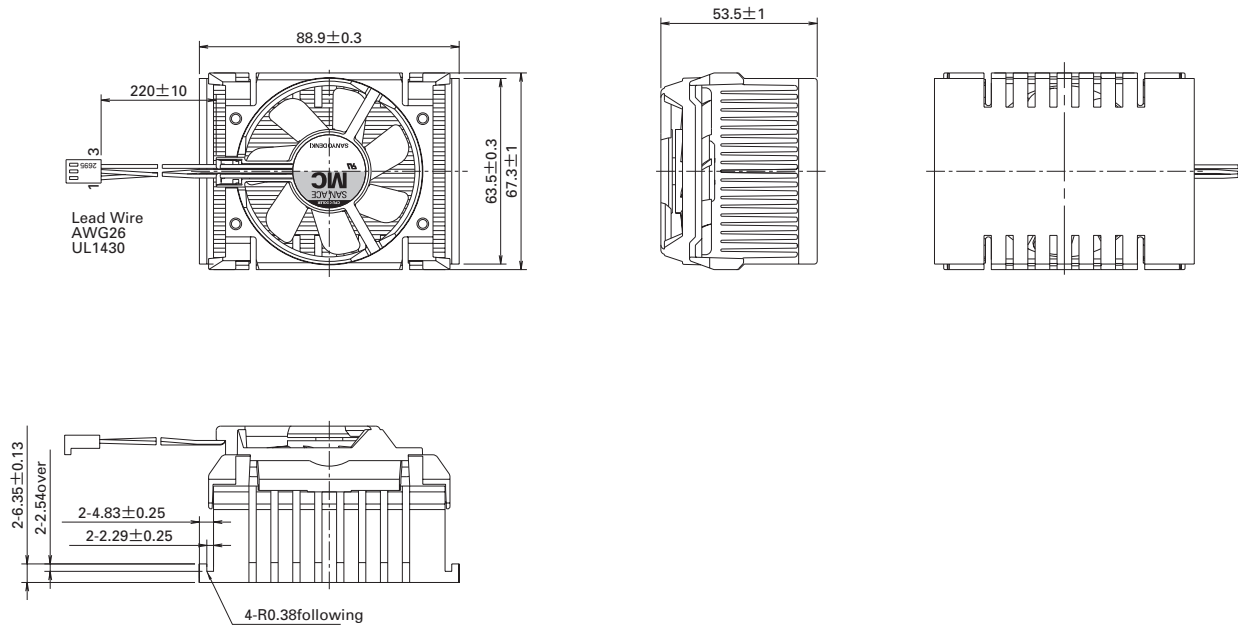

CPU Coolers  
Liquid Cooling  
Solution System

Socket473

# CPU Cooler

## For Intel® Pentium® III Processor 1.4GHz (FC-PGA2)

### General specifications

Material	Frame, impeller : resin mold Heat sink : aluminum
Life Expectancy	Varies for each model (Survival rate: 90% at 60°C, rated voltage, and continuously run in a free air state)
Motor Protection System	Current blocking function (with reverse polarity protection)
Dielectric Strength	50/60 Hz, 500VAC, 1 minute (between lead conductor and frame)
Noise Measurement Method	Measured at 1m from the air inlet
Operating Temperature Range	Varies for each model (Non-condensing)
Lead Wire	⊕yellow (connector No.2 side) ⊖black (connector No.1 side) Ⓢ(sensor) green (connector No.3 side)
Connector	Molex 22-01-3037 : P/N2695-03RP
Contact	Molex P/N5159PBT-equivalent
Mass	180g



### Specifications

Model No.	Rated Voltage (V)	Operating Voltage Range (V)	Rated Current (A)	Rated Speed (min <sup>-1</sup> )	$\theta_{c-a}$ Thermal Resistance (K/W)	Noise (dB [A])	Operating Temperature Range (°C)	Life Expectancy (h)
<b>109X7612H1176</b>	12	7~13.8	0.1	3,900	0.59	31	0 ~ +70	40,000

**Dimensions (unit : mm)**

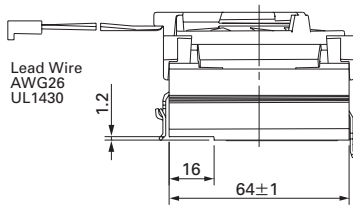
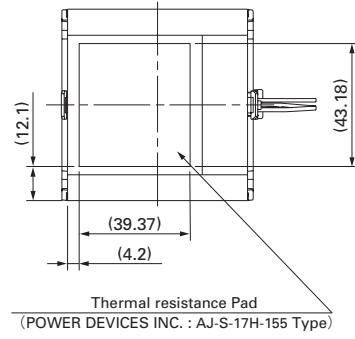
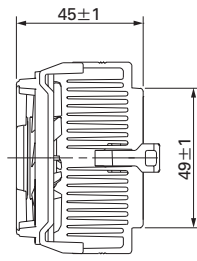
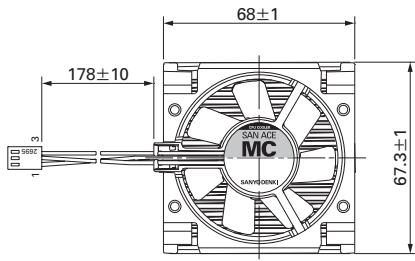

CPU Coolers  
Liquid Cooling  
Solution System

FC-PGA2

# CPU Cooler

## For Intel® Pentium® III Processor 1.4GHz (FC-PGA2)

### General specifications

- Material .....Frame, impeller : resin mold  
Heat sink : aluminum base + copper fin
- Life Expectancy .....Varies for each model (Survival rate: 90% at 60°C,  
rated voltage, and continuously run in a free air state)
- Motor Protection System .....Current blocking function (with reverse polarity protection)
- Dielectric Strength .....50/60 Hz, 500VAC, 1 minute (between lead conductor and frame)
- Noise Measurement Method .....Measured at 1m from the air inlet
- Operating Temperature Range .....Varies for each model (Non-condensing)
- Lead Wire .....⊕yellow (connector No.2 side)  
⊖black (connector No.1 side)  
Ⓢ(sensor) green (connector No.3 side)
- Connector .....Molex 22-01-3037 : P/N2695-03RP
- Contact .....Molex P/N5159PBT or 2759T-equivalent
- Mass .....145g



CPU Coolers  
Liquid Cooling  
Solution System

### Specifications

Model No.	Rated Voltage (V)	Operating Voltage Range (V)	Rated Current (A)	Rated Speed (min <sup>-1</sup> )	$\theta_{c-a}$ Thermal Resistance (K/W)	Noise (dB [A])	Operating Temperature Range (°C)	Life Expectancy (h)
<b>109X7412S4016</b>	12	7~13.8	0.22	6,000	0.625	42	0 ~+70	40,000

FC-PGA2

**Dimensions (unit : mm)**

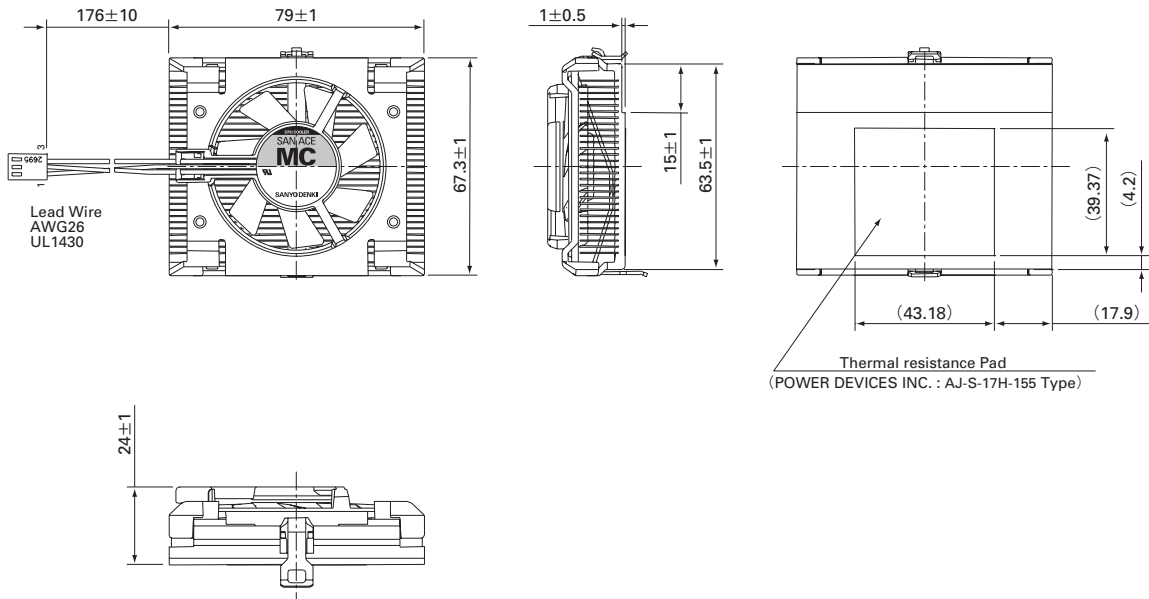

# CPU Cooler

## For Intel® Pentium® III Processor 800MHz (FC-PGA)

### General specifications

Material	Frame, impeller : resin mold Heat sink : aluminum
Life Expectancy	Varies for each model (Survival rate: 90% at 60°C, rated voltage, and continuously run in a free air state)
Motor Protection System	Current blocking function (with reverse polarity protection)
Dielectric Strength	50/60 Hz, 500VAC, 1 minute (between lead conductor and frame)
Noise Measurement Method	Measured at 1m from the air inlet
Operating Temperature Range	Varies for each model (Non-condensing)
Post Header	AMP P/N 173981-3 or equivalent Kyocera Elco P/N 00-8283-0312-00-000 or compatible ⊕No.3Pin ⊖No.2Pin Ⓢ(sensor) No.1Pin
Mass	110g



### Specifications

Model No.	Rated Voltage (V)	Operating Voltage Range (V)	Rated Current (A)	Rated Speed (min <sup>-1</sup> )	$\theta_{c-a}$ Thermal Resistance (K/W)	Noise (dB [A])	Operating Temperature Range (°C)	Life Expectancy (h)
109X6512A2016	12	7~13.8	0.07	4,800	1.15	35	0 ~ +70	40,000



**Dimensions (unit : mm)**

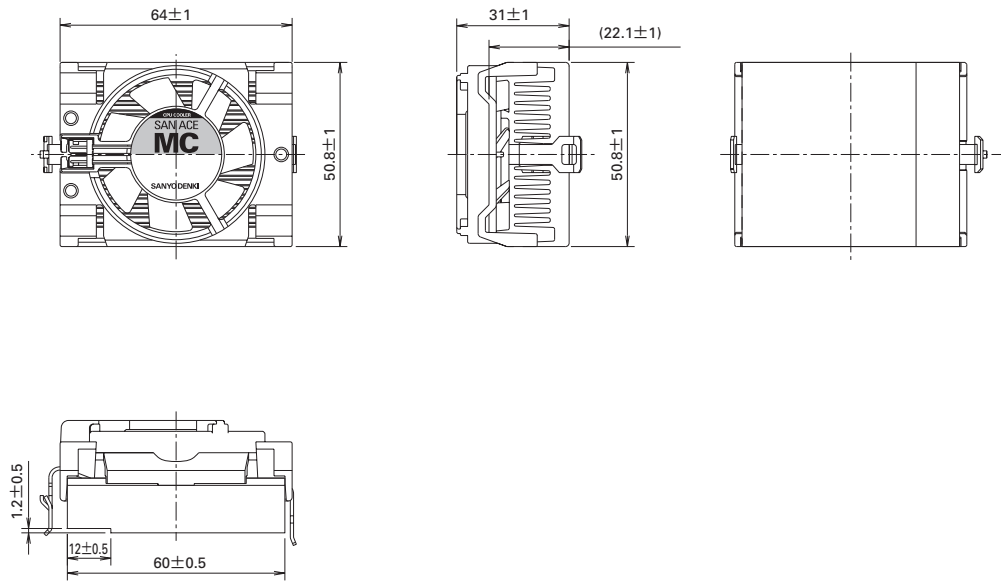

CPU Coolers  
Liquid Cooling  
Solution System

**Relay harness**

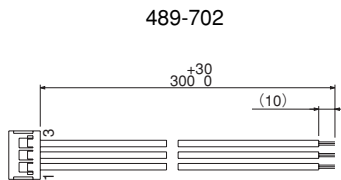

Connector : AMP 179228-3  
Contact : AMP 179518-1  
or 179227-1  
Read Wire : AWG24 UL1007

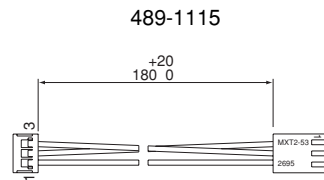

Connector : Molex P/N 2695-03RP  
Contact : Molex P/N 5159PBT  
or equivalent  
Read Wire : AWG24 UL1007

FC-PGA

# Liquid Cooling Solution System

## " SAN ACE MC-Liquid" Preeminent cooling performance

### General specifications

- Material .....Plastics:Fan frame, Fan impeller, Fan Grad. Pump casing  
Pump impeller, Tube, Gasket stand  
Aluminum:pump motor casing, Radiator  
Rubber Sponge : Gasket  
Copper:Cold plate
- Life Expectancy .....Varies for each model (Survival rate: 90% at 60°C,  
rated voltage,and continuously run in a free air state)
- Motor Protection System ....Current blocking function (with reverse polarity protection)
- Dielectric Strength .....50/60 Hz, 500VAC, 1 minute (between lead conductor and frame)
- Noise Measurement Method ..Measured at 1m from the air inlet Side on Fan
- Operating Temperature Range ..Varies for each model (Non-condensing)
- Fan .....Thermal Speed Control
- Mass .....1,150g



CPU Coolers  
Liquid Cooling  
Solution System

### Specifications

Model No.	Rated Voltage (V)	Operating Voltage Range (V)		Rated Current (A)		Rated Speed (min <sup>-1</sup> )		θ c-a Thermal Resistance (K/W)	Noise (dB [A])	Operating Temperature Range (°C)	Life Expectancy (h)
		Fan	Pump	Fan	Pump	Fan	Pump				
109-LC1-001	12	7~12.6	7~12.6	0.25	0.12	2,400	2,000	0.22	42	0 ~ +60	40,000
						1,300	2,000	0.255	28		

Liquid cooling  
solution system

**Dimensions (unit : mm)**

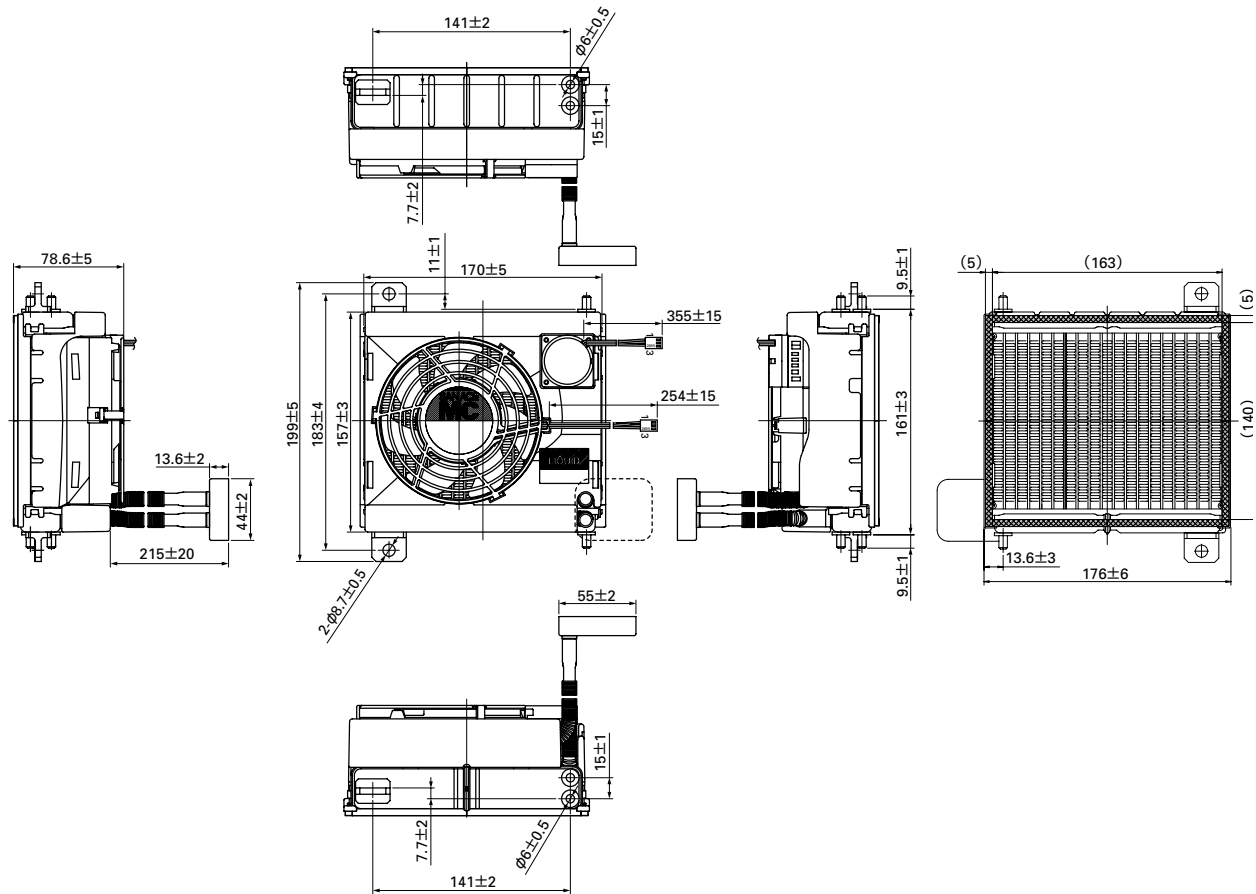

CPU Coolers  
Liquid Cooling  
Solution System

**Mounting Clip (unit : mm)**

**For Socket478**  
Model No : 109-1017

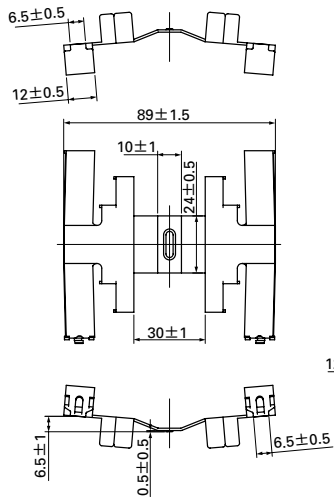

Material : Stainless steel

**For 775-land LGA Package**  
Model No : 109-1026

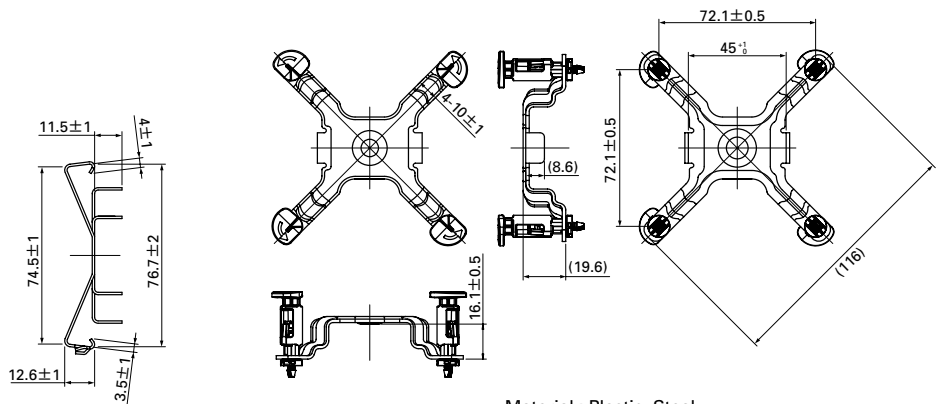

Material : Plastic, Steel

Liquid cooling  
solution system



# COOLING SYSTEMS

## AC FAN

## AC Fans

### Domain diagram

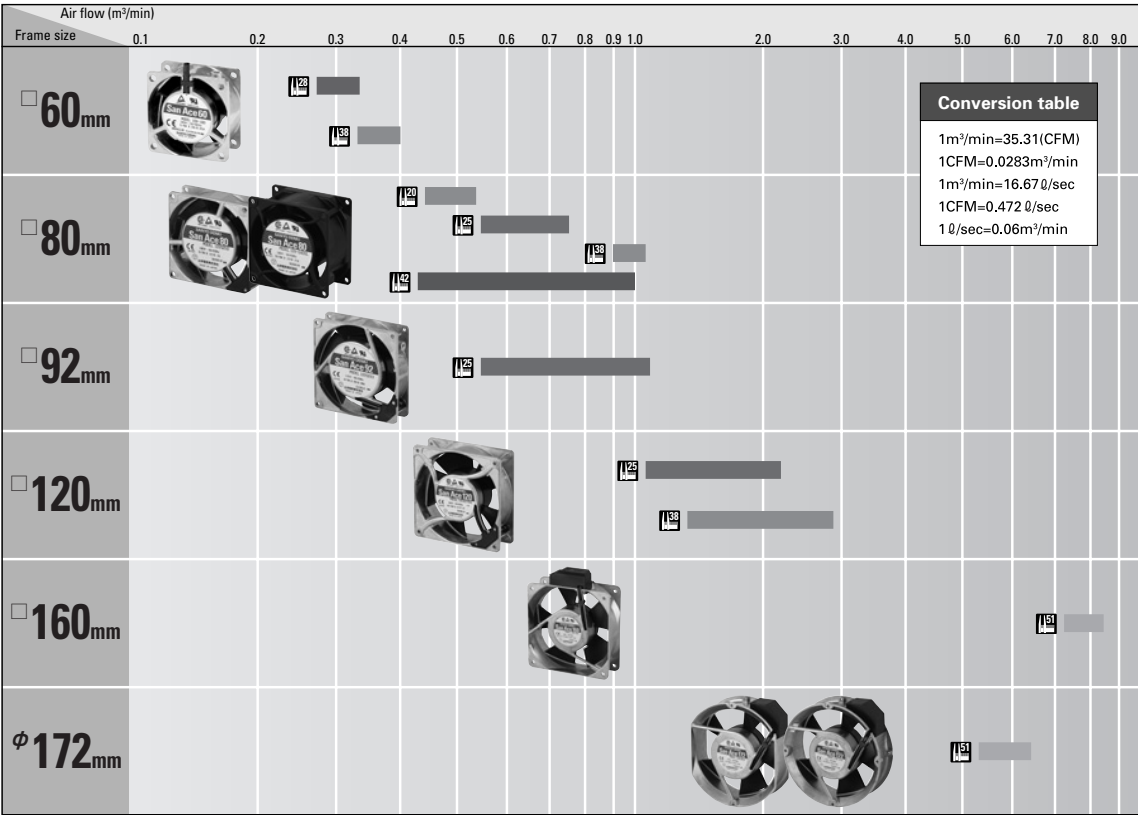

AC Fans

60mm

80mm

92mm

120mm

160mm

172mm

# AC Fan

□ **60mm**  
San Ace 60



## General specifications

Material .....Frame:Aluminum, Impeller:Plastics  
 Life Expectancy .....Varies for each model (Survival rate: 90% at 60°C, rated voltage,and continuously run in a free air state)  
 Motor Construction .....Shaded coil motor  
 Motor Protection System .....Impedance protection  
 Dielectric Strength .....50/60 Hz, 1500VAC, 1 minute (between lead conductor and frame)  
 Noise Measurement Method .....Measured at 1m from the air inlet  
 Operating Temperature Range .....Varies for each model (Non-condensing)  
 Operating Voltage Range .....±10%  
 Lead Wire .....black, 2pcs  
 Mass .....120g (28mm thick) 170g (38mm thick)

## 28mm thick Specifications

Model No.	Voltage (V)	Frequency (Hz)	Input (W)	Current (A)	Locked Rotor Current (A)	Rated Speed (min <sup>-1</sup> )	Air Flow (m <sup>3</sup> /min) (CFM)	Static Pressure (Pa) (inchH <sub>2</sub> O)	Noise (dB [A])	Operating Temperature Range (°C)	Life Expectancy (h)
<b>109-180</b>	100	50/60	5/4	0.06/0.05	0.07/0.06	2250/2700	0.27/0.33 9.5/11.7	11.8/18.6 0.047/0.075	24/26	-30 ~ +70	25,000
<b>109-183</b>	115				0.06/0.05						

## Air Flow and Static Pressure Characteristics

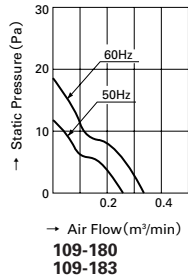

## 38mm thick Specifications

Model No.	Voltage (V)	Frequency (Hz)	Input (W)	Current (A)	Locked Rotor Current (A)	Rated Speed (min <sup>-1</sup> )	Air Flow (m <sup>3</sup> /min) (CFM)	Static Pressure (Pa) (inchH <sub>2</sub> O)	Noise (dB [A])	Operating Temperature Range (°C)	Life Expectancy (h)
<b>109-130</b>	100	50/60	6/5	0.08/0.07	0.08/0.07	2600/3150	0.33/0.4 11.7/14.1	16.3/23.3 0.065/0.094	28/30	-30 ~ +60	25,000
<b>109-133</b>	115			0.07/0.06	0.07/0.06						

## Air Flow and Static Pressure Characteristics

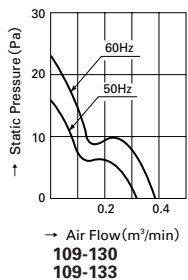

**Dimensions (unit : mm)**

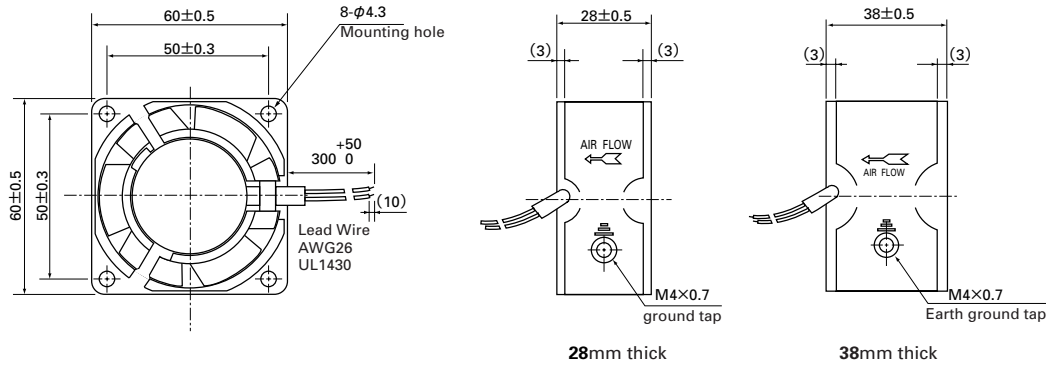

**Reference dimension of mounting holes and vent opening (unit : mm)**

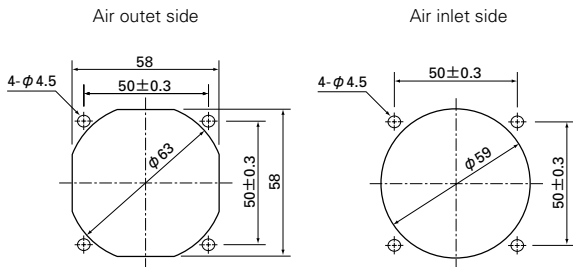

**Wiring diagram**

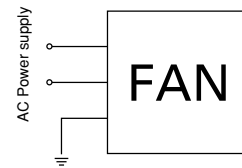

AC Fans

60mm





# 38mm thick Specifications

Model No.	Voltage (V)	Frequency (Hz)	Input (W)	Current (A)	Locked Rotor Current (A)	Rated Speed (min <sup>-1</sup> )	Air Flow (m <sup>3</sup> /min) (CFM)	Static Pressure (Pa) (inchH <sub>2</sub> O)	Noise (dB [A])	Operating Temperature Range (°C)	Life Expectancy (h)
<b>109-150</b>	100	50/60	9/8	0.13/0.11	0.17/0.15	2700/3150	0.9/1.05 31.8/37.1	31.4/44.1 0.126/0.177	35/39	-30 ~ +60	25,000
<b>109-153</b>	115			0.11/0.1	0.14/0.12						
<b>109-151</b>	200			0.07/0.06	0.09/0.08						
<b>109-154</b>	230			0.06/0.05	0.08/0.07						

## Air Flow and Static Pressure Characteristics

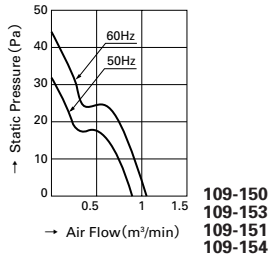

## Wiring diagram

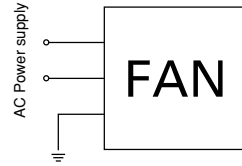

## Dimensions (unit : mm)

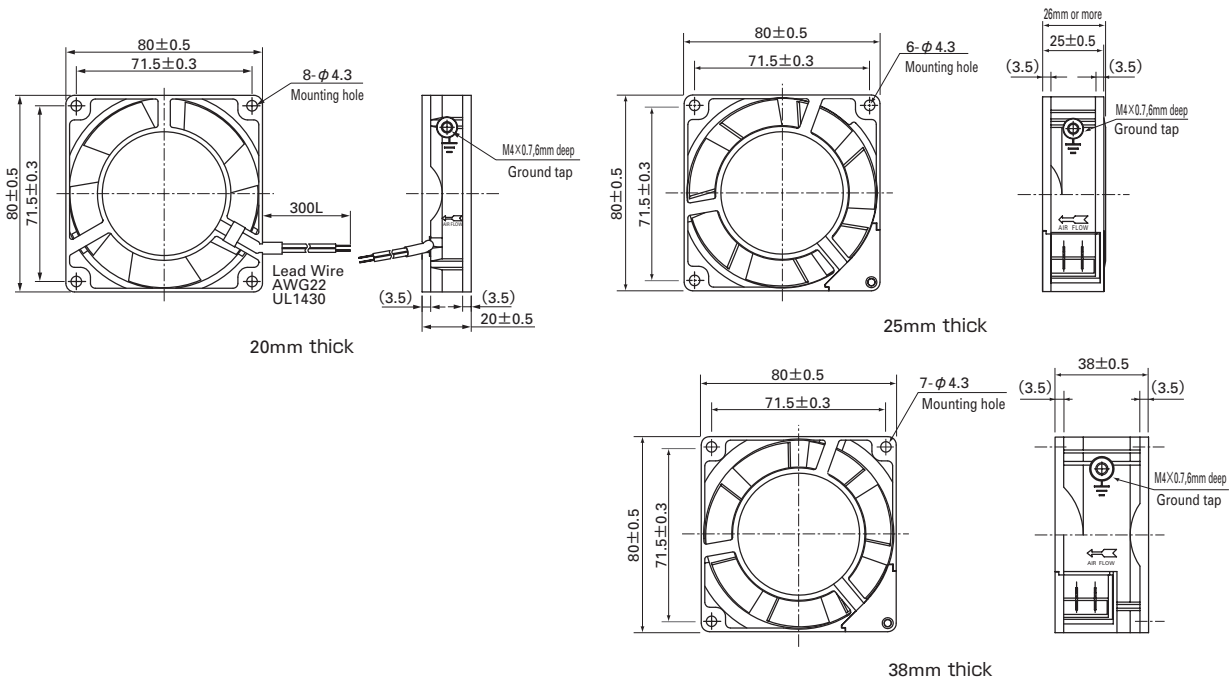

AC Fans

80mm

## Reference dimension of mounting holes and vent opening (unit : mm)

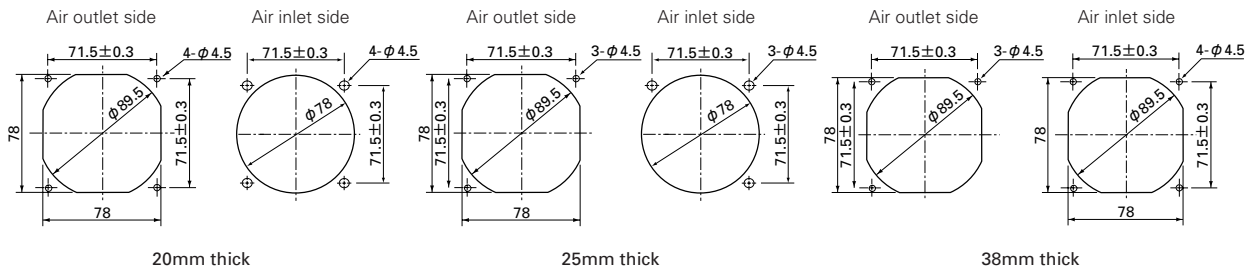

# AC Fan

**80mm**  
San Ace 80



## General specifications

- Material .....Frame:Aluminum, Impeller:Plastics
- Life Expectancy .....Varies for each model (Survival rate: 90% at 60°C, rated voltage,and continuously run in a free air state)
- Motor Construction .....Shaded coil motor
- Motor Protection System .....Impedance protection
- Dielectric Strength .....50/60 Hz, 1500VAC, 1 minute (between lead conductor and frame)
- Noise Measurement Method .....Measured at 1m from the air inlet
- Operating Temperature Range .....Varies for each model (Non-condensing)
- Operating Voltage Range .....±10%
- Plug cord .....For general 489-008(L10,L21,L35)
- Mass .....410g

## 42mm thick Specifications

Model No.	Voltage (V)	Frequency (Hz)	Input (W)	Current (A)	Locked Rotor Current (A)	Rated Speed (min <sup>-1</sup> )	Air Flow (m <sup>3</sup> /min) (CFM)	Static Pressure (Pa) (inchH <sub>2</sub> O)	Noise (dB [A])	Operating Temperature Range (°C)	Life Expectancy (h)
<b>109-040UL</b>	100	50/60	10/9	0.13/0.11	0.16/0.14	2650/3100	0.85/1.0 30.0/35.3	24.5/35.3 0.098/0.142	40/44	-30 ~ +60	25,000
<b>109-043UL</b>	115			0.11/0.1	0.14/0.12						
<b>109-041UL</b>	200			0.07/0.06	0.08/0.07						
<b>109-044UL</b>	230			0.06/0.05	0.07/0.06						
※ <b>109-047UL</b>	100			4/3.5	0.05/0.05						
※ <b>109-033UL</b>	115	0.04/0.04	0.04/0.04								

※represents low-speed.

## Air Flow and Static Pressure Characteristics

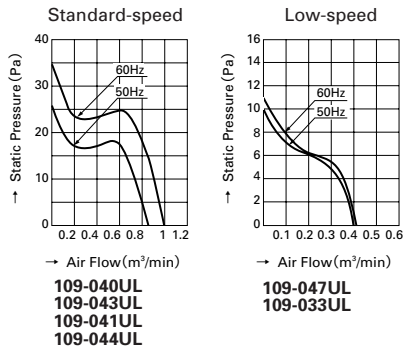

80mm

AC Fans





## Dimensions (unit : mm)

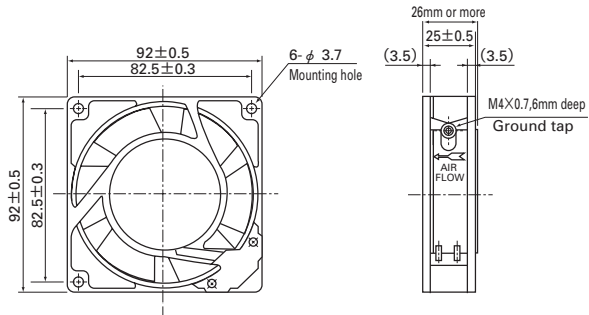

## Reference dimension of mounting holes and vent opening (unit : mm)

Air inlet side · Air outlet side

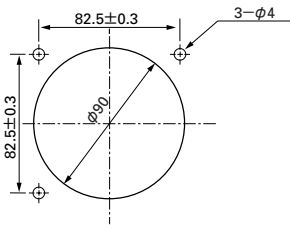

## Wiring diagram

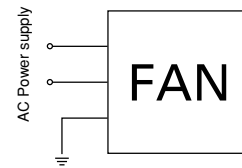

AC Fans

92mm

# AC Fan

# 120mm San Ace 120



### General specifications

Material .....Frame:Aluminum, Impeller:Plastics  
 Life Expectancy .....Varies for each model (Survival rate: 90% at 60°C,  
 rated voltage,and continuously run in a free air state)  
 Motor Construction.....Shaded coil motor  
 Motor Protection System .....Impedance protection  
 Dielectric Strength .....50/60 Hz, 1500VAC, 1 minute (between lead conductor and frame)  
 Noise Measurement Method ..Measured at 1m from the air inlet  
 Operating Temperature Range .....Varies for each model (Non-condensing)  
 Operating Voltage Range .....±10%  
 Plug cord.....489-006 (L10,L21) / 489-016(L10,L21)  
 38mm thick For UL/CSA 489-007 (L10,L21) 25mm thick For UL/CSA 489-047 (L10,L21)  
 ※Be sure to use a UL/CSA plug cord with any products with a 'UL' at the end of their model numbers.  
 Mass .....370g (25mm thick) 550g (38mm thick)

## 25mm thick Specifications

Model No.	Voltage (V)	Frequency (Hz)	Input (W)	Current (A)	Locked Rotor Current (A)	Rated Speed (min <sup>-1</sup> )	Air Flow (m <sup>3</sup> /min) (CFM)	Static Pressure (Pa) (inchH <sub>2</sub> O)	Noise (dB [A])	Operating Temperature Range (°C)	Life Expectancy (h)
<b>109S085</b>	100	50/60	13.5/12	0.16/0.14	0.19/0.17	2500/2900	1.92/2.22 67.8/78.4	49/53.9 0.197/0.216	38/41	-30 ~ +60	25,000
<b>109S084</b>	115			0.14/0.12	0.16/0.15						
<b>109S088</b>	200			0.08/0.07	0.1 /0.09						
<b>109S087</b>	230			0.07/0.06	0.08/0.07						
☆ <b>109S081</b>	100	9.5/8.5	9.5/8.5	0.11	0.11/0.1	2200/2350	1.63/1.78 57.6/62.9	29.4/26.3 0.118/0.106	34/35	-30 ~ +60	25,000
☆ <b>109S083</b>	115			0.1	0.1 /0.09						
☆ <b>109S082</b>	200			0.07	0.07/0.06						
☆ <b>109S089</b>	230			0.06	0.06/0.05						
※ <b>109S086</b>	100	12/10	0.14/0.12	0.15/0.13	1400/1600	1.11/1.35 39.2/47.7	15.7/19.6 0.063/0.079	24/27			

☆ represents half-speed. ※ represents low-speed

### Air Flow and Static Pressure Characteristics

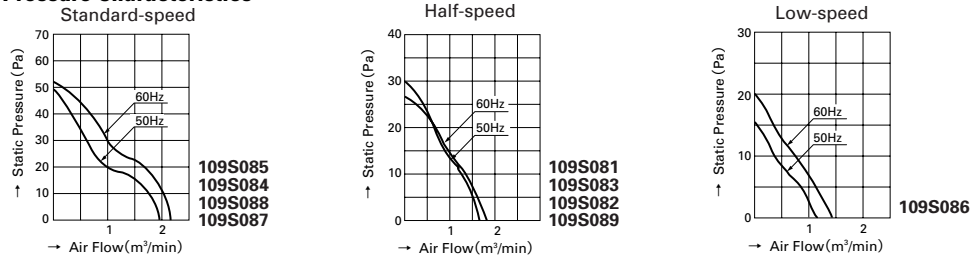

## 38mm thick Specifications

Model No.	Voltage (V)	Frequency (Hz)	Input (W)	Current (A)	Locked Rotor Current (A)	Rated Speed (min <sup>-1</sup> )	Air Flow (m <sup>3</sup> /min) (CFM)	Static Pressure (Pa) (inchH <sub>2</sub> O)	Noise (dB [A])	Operating Temperature Range (°C)	Life Expectancy (h)
<b>109S005</b>	100	50/60	14/12	0.18/0.16	0.25/0.22	2700/3100	2.35/2.7 83/95.4	55.9/65.7 0.224/0.264	40/43	-30 ~ +60	25,000
<b>109S005UL</b>				0.16/0.14	0.21/0.18						
<b>109S024</b>	120			0.09/0.08	0.13/0.11						
<b>109S024UL</b>	115			0.08/0.07	0.11/0.09						
<b>109S008</b>	200			0.09/0.08	0.13/0.11						
<b>109S008UL</b>				0.08/0.07	0.11/0.09						
<b>109S025</b>	230	0.08/0.07	0.11/0.09								
<b>109S025UL</b>		0.08/0.07	0.11/0.09								

### Air Flow and Static Pressure Characteristics

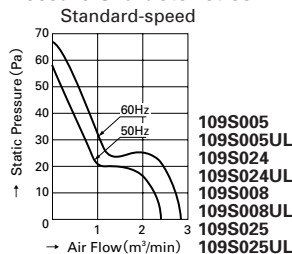

# 38mm thick Specifications

Model No.	Voltage (V)	Frequency (Hz)	Input (W)	Current (A)	Locked Rotor Current (A)	Rated Speed (min <sup>-1</sup> )	Air Flow (m <sup>3</sup> /min) (CFM)	Static Pressure (Pa) (inchH <sub>2</sub> O)	Noise (dB [A])	Operating Temperature Range (°C)	Life Expectancy (h)
☆109S029UL	100	50/60	14/12	0.18/0.16	0.23/0.21	2450/2700	2.15/2.35 76 /83	44.1/49.0 0.177/0.197	38/40	-30 ~ +60	25,000
☆109S013			13/11	0.16/0.14	0.16/0.15	1800/2000	1.54/1.72 54.4/60.8	24 /27 0.096/0.108	30/32		
☆109S013UL			7/ 7	0.1 /0.09	0.1 /0.09	1650/1700	1.45/1.5 51.2/53	17.6/17.6 0.071/0.071	28/28		
※109S006			7/ 7	0.1 /0.09	0.1 /0.09	1650/1700	1.45/1.5 51.2/53	17.6/17.6 0.071/0.071	28/28		
※109S006UL	115	10/10	0.13/0.11	0.13/0.11	1800/1900	1.56/1.64 55 /57.9	20 /20.6 0.080/0.083	30/31			
※109S010	200	7/ 7	0.05/0.04	0.05/0.04	1650/1700	1.45/1.5 51.2/53	17.6/17.6 0.071/0.071	28/28			
※109S010UL	200	7/ 7	0.05/0.04	0.05/0.04	1650/1700	1.45/1.5 51.2/53	17.6/17.6 0.071/0.071	28/28			
	240	11/11	0.06/0.05	0.06/0.05	1800/1950	1.58/1.68 55.8/59.3	20.6/21.6 0.083/0.087	30/32			

☆ represents half-speed. ※ represents low-speed

## Air Flow and Static Pressure Characteristics

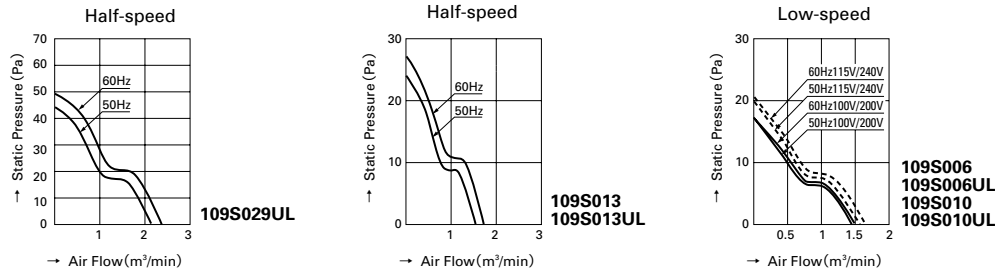

# 38mm thick Specifications

Model No.	Voltage (V)	Frequency (Hz)	Input (W)	Current (A)	Locked Rotor Current (A)	Rated Speed (min <sup>-1</sup> )	Air Flow (m <sup>3</sup> /min) (CFM)	Static Pressure (Pa) (inchH <sub>2</sub> O)	Noise (dB [A])	Operating Temperature Range (°C)	Life Expectancy (h)
109S075UL	100	50/60	18/16	0.24/0.21	0.32/0.28	2700/3100	2.5/2.9 88.3/102.5	57.9/68.7 0.233/0.276	42/45	-30 ~ +60	25,000
109S074UL	115			0.21/0.18	0.27/0.24						
109S078UL	200			0.12/0.1	0.16/0.14						
109S072UL	230			0.11/0.09	0.14/0.13						

## Air Flow and Static Pressure Characteristics

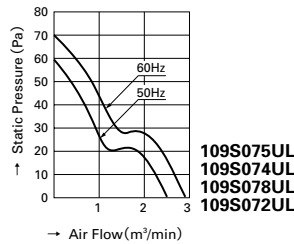

## Reference dimension of mounting holes and vent opening (unit : mm)

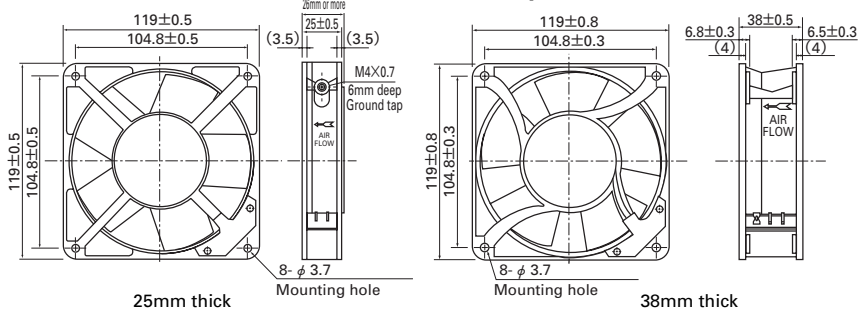

## Reference dimension of mounting holes and vent opening (unit : mm)

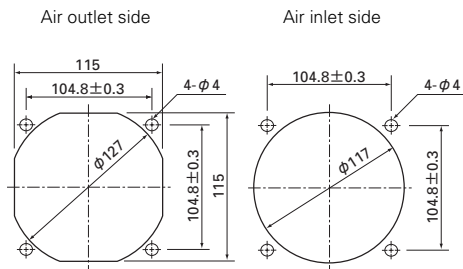

## Wiring diagram

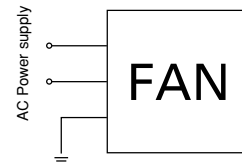

AC Fans

120mm





**Dimensions (unit : mm)**

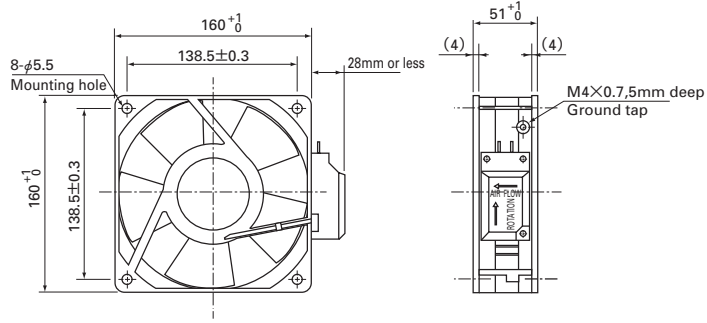

**Reference dimension of mounting holes and vent opening (unit : mm)**

Air inlet side · Air outlet side

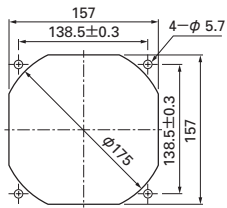

**Wiring diagram**

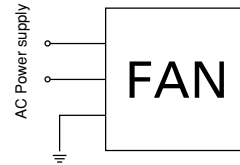

AC Fans

160mm



**Dimensions (unit : mm)**

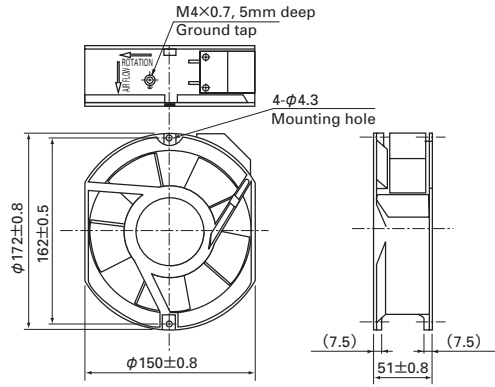

**Reference dimension of mounting holes and vent opening (unit : mm)**

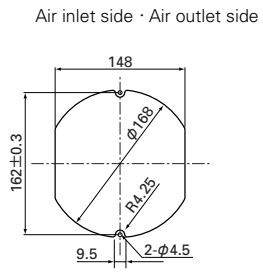

**Wiring diagram**

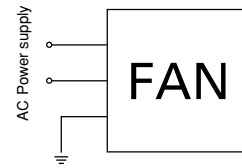

AC Fans

172mm

# AC Fan

Ø **172mm**  
San Ace 172



## General specifications

Material .....Frame:Aluminum, Impeller:Plastics  
 Life Expectancy .....Varies for each model (Survival rate: 90% at 60°C,  
 rated voltage,and continuously run in a free air state)  
 Motor Construction .....Capacitor motor  
 Motor Protection System .....Thermal protection  
 Dielectric Strength .....50/60 Hz, 1500VAC, 1 minute (between lead conductor and frame)  
 Noise Measurement Method ..Measured at 1m from the air inlet  
 Operating Temperature Range ....Varies for each model (Non-condensing)  
 Operating Voltage Range .....±10%  
 Plug cord .....For UL/CSA 489-084 (L10,L21)  
 For UL/CSA 489-086 (L10,L21)  
 Mass .....960g

## 51 mm thick (Round type) Specifications

Model No.	Voltage (V)	Frequency (Hz)	Input (W)	Current (A)	Locked Rotor Current (A)	Rated Speed (min <sup>-1</sup> )	Air Flow (m <sup>3</sup> /min) (CFM)	Static Pressure (Pa) (inchH <sub>2</sub> O)	Noise (dB [A])	Operating Temperature Range (°C)	Life Expectancy (h)
<b>109-311</b>	100	50/60	27/25	0.33/0.25	0.65/0.64	2900/3500	5.3/6.4 187.3/226.1	147/196 0.590/0.787	47/51	-30 ~ +60	25,000
<b>109-314</b>	115			0.29/0.22	0.55/0.54						
<b>109-312</b>	200			0.16/0.13	0.33/0.32						
<b>109-313</b>	230			0.14/0.11	0.28/0.27						

## Air Flow and Static Pressure Characteristics

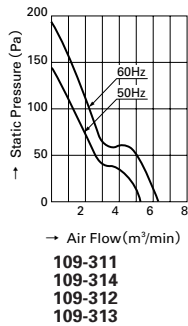

172mm

**Dimensions (unit : mm)**

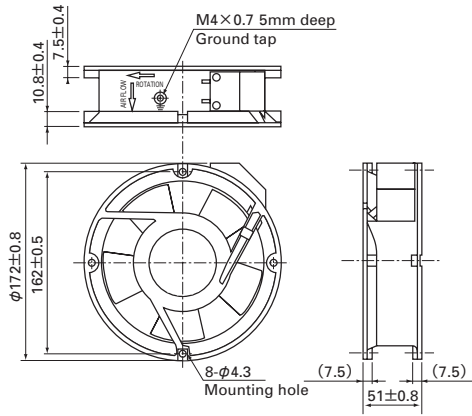

**Reference dimension of mounting holes and vent opening (unit : mm)**

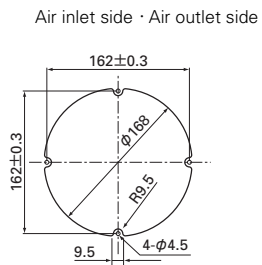

**Wiring diagram**

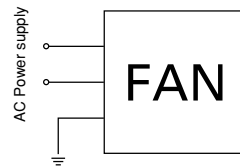

AC Fans

172mm

## AC Fan With Sensor

92mm  
San Ace 92



### General specifications

Material ..... Frame:Aluminum, Impeller:Plastics  
 Life Expectancy .....Varies for each model (Survival rate: 90% at 60°C, rated voltage,and continuously run in a free air state)  
 Motor Construction .....Shaded coil motor  
 Motor Protection System .....Impedance protection  
 Dielectric Strength ..... between AC input and DC input (Sensor output) : 50/60 Hz, 1000 VAC, 1 minute  
 between AC input and G:50/60 Hz, 1500 VAC, 1 minute  
 between G and DC input (Sensor output) : 50/60 Hz, 1000 VAC, 1 minute  
 Noise Measurement Method .....Measured at 1m from the air inlet  
 Operating Temperature Range .....Varies for each model (Non-condensing)  
 Operating Voltage Range .....±10%  
 Sensor-Purpose Lead Wire .....⊕brown, ⊖black, (Sensor) yellow  
 Plug cord ..... For general 489-016 (L10, L21)  
 For UL/CSA 489-047 (L10,L21)  
 Mass .....310g

### 25mm thick Specifications

Model No.	Voltage (V)	Frequency (Hz)	Input (W)	Current (A)	Locked Rotor Current (A)	Rated Speed (min <sup>-1</sup> )	Air Flow (m <sup>3</sup> /min) (CFM)	Static Pressure (Pa) (inchH <sub>2</sub> O)	Noise (dB [A])	Operating Temperature Range (°C)	Life Expectancy (h)
<b>109S491</b>	100	50/60	8/ 7	0.1 /0.09	0.13/0.12	2700/3100	0.95/1.1 33.6/38.9	39.2/49.0 0.157/0.197	35/38	-10~+60	25,000
<b>109S493</b>	115			0.09/0.08	0.11/0.1						
<b>109S492</b>	200		11/10	0.07/0.06	0.08/0.08						
<b>109S494</b>	230		10/ 9	0.06/0.05	0.07/0.07						
☆ <b>109S495</b>	100		8/ 7	0.1 /0.09	0.11/0.1						
※ <b>109S496</b>		7/ 6	0.09/0.08	0.09/0.08	1500/1700	0.55/0.65 19.4/23	12.5/16.3 0.050/0.065	24/27			

☆ represents half-speed. ※ represents low-speed

### Air Flow and Static Pressure Characteristics

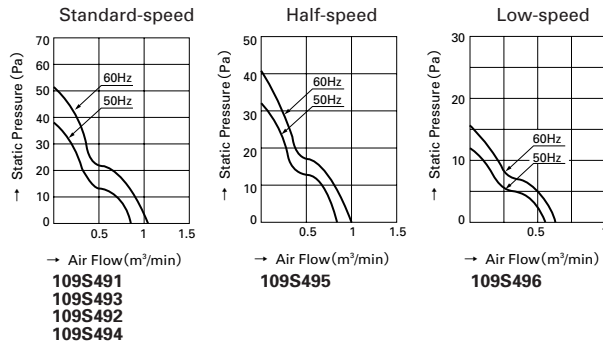

**Dimensions (unit : mm)**

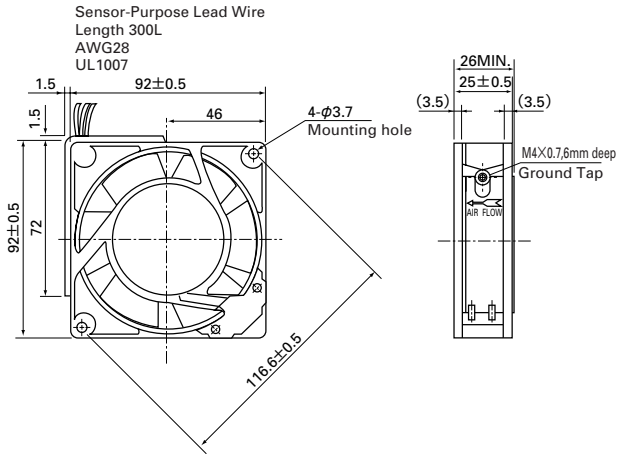

**Reference dimension of mounting holes and vent opening (unit : mm)**

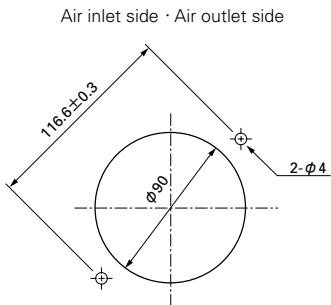

**Wiring diagram (For fan power supply)**

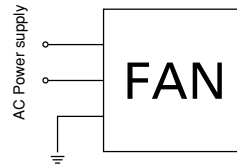

**Wiring diagram (Sensor Output Circuit)**

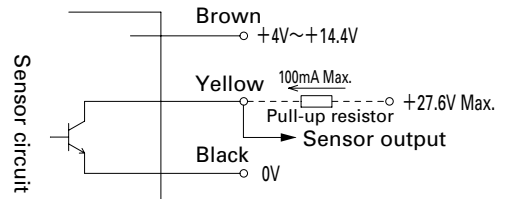

AC Fans

92mm

# AC Fan With Sensor

120mm  
San Ace 120



## General specifications

Material .....Frame:Aluminum, Impeller:Plastics  
 Life Expectancy .....Varies for each model (Survival rate: 90% at 60°C,  
 rated voltage,and continuously run in a free air state)  
 Motor Construction.....Shaded coil motor  
 Motor Protection System .....Impedance protection  
 Dielectric Strength .....between AC input and DC input (Sensor output) : 50/60 Hz, 1000 VAC, 1 minute  
 between AC input and G:50/60 Hz, 1500 VAC, 1 minute  
 between G and DC input (Sensor output) : 50/60 Hz, 1000 VAC, 1 minute  
 Noise Measurement Method ..Measured at 1m from the air inlet  
 Operating Temperature Range .....Varies for each model (Non-condensing)  
 Operating Voltage Range .....±10%  
 Sensor-Purpose Lead Wire .....⊕brown, ⊖black, (Sensor) yellow  
 Plug cord.....25mm thick For 489-016 (L10, L21)  
 38mm thick For UL/CSA 489-007 (L10, L21)  
 25mm thick For UL/CSA 489-047 (L10, L21)  
 ※Be sure to use a UL/CSA plug cord with any products with a 'UL' at the end of their model numbers.  
 Mass .....390g (25mm thick) 580g (38mm thick)

## 25mm thick Specifications

Model No.	Voltage (V)	Frequency (Hz)	Input (W)	Current (A)	Locked Rotor Current (A)	Rated Speed (min <sup>-1</sup> )	Air Flow (m <sup>3</sup> /min) (CFM)	Static Pressure (Pa) (inchH <sub>2</sub> O)	Noise (dB [A])	Operating Temperature Range (°C)	Life Expectancy (h)
109S485	100	50/60	13.5/12	0.16/0.14	0.19/0.17	2500/2900	1.92/2.22 67.8/78.4	48 /52 0.193/0.209	38/41	-10 ~+60	25,000
109S484	115			0.14/0.12	0.16/0.15						
109S488	200			0.08/0.07	0.1 /0.09						
109S487	230			0.07/0.06	0.08/0.07						
※109S486	100			12 /10	0.14/0.12						

※ represents low-speed

## Air Flow and Static Pressure Characteristics

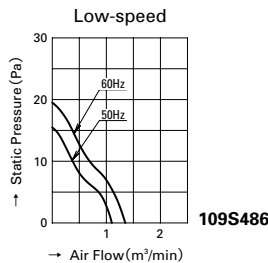
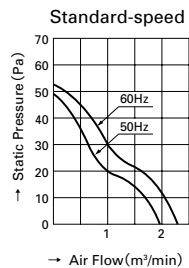

## 38mm thick Specifications

Model No.	Voltage (V)	Frequency (Hz)	Input (W)	Current (A)	Locked Rotor Current (A)	Rated Speed (min <sup>-1</sup> )	Air Flow (m <sup>3</sup> /min) (CFM)	Static Pressure (Pa) (inchH <sub>2</sub> O)	Noise (dB [A])	Operating Temperature Range (°C)	Life Expectancy (h)
109S405UL	100	50/60	14/12	0.18/0.16	0.25/0.22	2700/3100	2.35/2.7 83/95.4	55.9/65.7 0.224/0.264	40/43	-10 ~+60	25,000
109S424UL	115			0.16/0.14	0.21/0.18						
109S408UL	200			0.09/0.08	0.13/0.11						
109S425UL	230			0.08/0.07	0.11/0.09						
☆109S429UL	100			0.18/0.16	0.23/0.21						
※109S406UL		7/6	0.09/0.08	0.1 /0.09	1650/1700	1.45/1.5 51/53	17.7/17.7 0.071/0.071	28/28			

☆ represents half-speed. ※ represents low-speed

## Air Flow and Static Pressure Characteristics

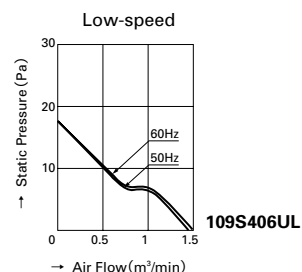
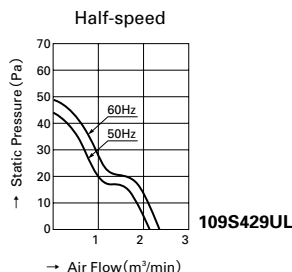
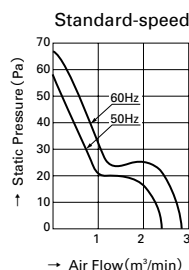



# 38mm thick Specifications

Model No.	Voltage (V)	Frequency (Hz)	Input (W)	Current (A)	Locked Rotor Current (A)	Rated Speed (min <sup>-1</sup> )	Air Flow (m <sup>3</sup> /min) (CFM)	Static Pressure (Pa) (inchH <sub>2</sub> O)	Noise (dB [A])	Operating Temperature Range (°C)	Life Expectancy (h)
109S475UL	100	50/60	18/16	0.24/0.21	0.32/0.28	2700/3100	2.5/2.9 88.3/102.4	57.9/68.7 0.233/0.276	42/45	-10 ~ +60	25,000
109S474UL	115			0.21/0.18	0.27/0.24						
109S478UL	200			0.12/0.1	0.16/0.14						
109S472UL	230			0.11/0.09	0.14/0.13						

## Air Flow and Static Pressure Characteristics

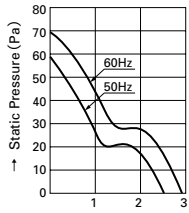

↑ Static Pressure (Pa)  
→ Air Flow (m<sup>3</sup>/min)

109S475UL  
109S474UL  
109S478UL  
109S472UL

## Dimensions (unit : mm)

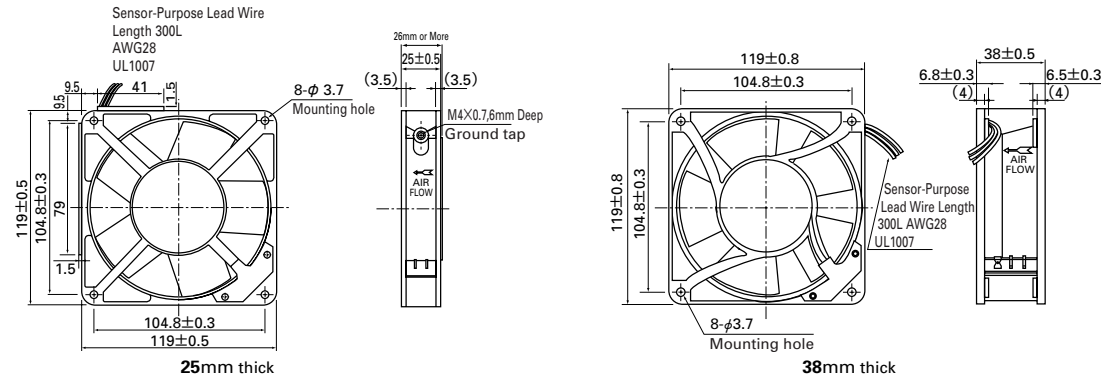

## Reference dimension of mounting holes and vent opening (unit : mm)

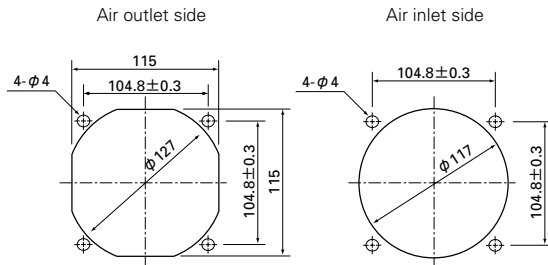

## Wiring diagram (For fan power supply)

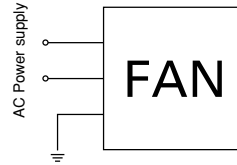

## Wiring diagram (Sensor Output Circuit)

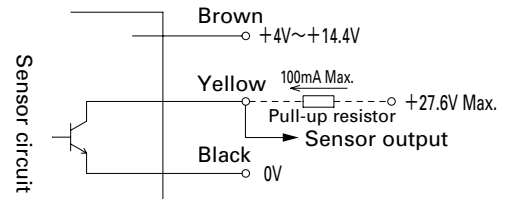

AC Fans

120mm

# AC Fan

With Sensor

□ **160mm**  
San Ace 160



### General specifications

- Material ..... Frame:Aluminum, Impeller:Plastics
- Life Expectancy .....Varies for each model (Survival rate: 90% at 60°C, rated voltage,and continuously run in a free air state)
- Motor Construction .....Capacitor motor
- Motor Protection System .....Thermal protection
- Dielectric Strength ..... between AC input and DC input (Sensor output) : 50/60 Hz, 1000 VAC, 1 minute  
between AC input and G:50/60 Hz, 1500 VAC, 1 minute  
between G and DC input (Sensor output) : 50/60 Hz, 1000 VAC, 1 minute
- Noise Measurement Method .....Measured at 1m from the air inlet
- Operating Temperature Range .....Varies for each model (Non-condensing)
- Operating Voltage Range ..... ± 10%
- Sensor-Purpose Lead Wire .....⊕brown, ⊖black, (Sensor) yellow
- Plug cord .....For UL/CSA 489-084 (L10, L21)  
489-086 (L10, L21)
- Mass .....1,100g

### 51mm thick Specifications

Model No.	Voltage (V)	Frequency (Hz)	Input (W)	Current (A)	Locked Rotor Current (A)	Rated Speed (min <sup>-1</sup> )	Air Flow (m <sup>3</sup> /min) (CFM)	Static Pressure (Pa) (inchH <sub>2</sub> O)	Noise (dB [A])	Operating Temperature Range (°C)	Life Expectancy (h)
<b>109-641</b>	100	50/60	37.5/33	0.43/0.35	0.72/0.70	2850/3350	7.2/8.5 254.4/300.4	156.8/166.6 0.630/0.669	56/60	-10 ~ +60	25,000
<b>109-644</b>	115			0.39/0.31	0.62/0.61						
<b>109-642</b>	200			0.23/0.18	0.36/0.35						
<b>109-643</b>	230			0.21/0.16	0.32/0.31						

### Air Flow and Static Pressure Characteristics

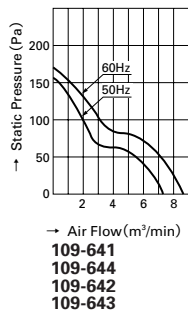

160mm

**Dimensions (unit : mm)**

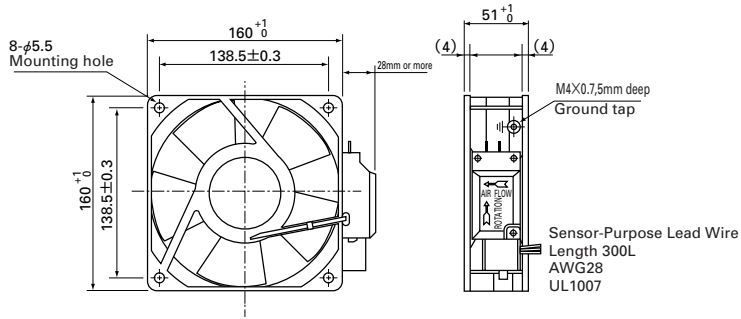

**Reference dimension of mounting holes and vent opening (unit : mm)**

Air inlet side · Air outlet side

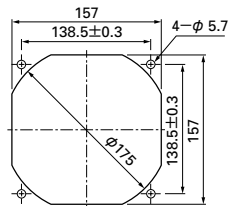

**Wiring diagram (For fan power supply)**

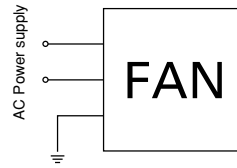

**Wiring diagram (Sensor Output Circuit)**

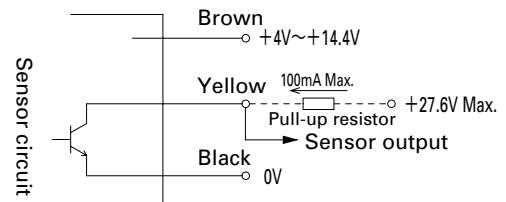

AC Fans

160mm

# AC Fan

With Sensor

Ø172mm  
San Ace 172



### General specifications

- Material .....Frame:Aluminum, Impeller:Plastics
- Life Expectancy .....Varies for each model (Survival rate: 90% at 60°C, rated voltage,and continuously run in a free air state)
- Motor Construction .....Capacitor motor
- Motor Protection System .....Thermal protection
- Dielectric Strength .....between AC input and DC input (Sensor output) : 50/60 Hz, 1000 VAC, 1 minute  
between AC input and G:50/60 Hz, 1500 VAC, 1 minute  
between G and DC input (Sensor output) : 50/60 Hz, 1000 VAC, 1 minute
- Noise Measurement Method .....Measured at 1m from the air inlet
- Operating Temperature Range .....Varies for each model (Non-condensing)
- Operating Voltage Range .....±10%
- Sensor-Purpose Lead Wire .....⊕brown, ⊖black, (Sensor) yellow
- Plug Cord .....For UL/CSA 489-084 (L10, L21)  
489-086 (L10, L21)
- Mass .....980g

## 51 mm thick Specifications

Model No.	Voltage (V)	Frequency (Hz)	Input (W)	Current (A)	Locked Rotor Current (A)	Rated Speed (min <sup>-1</sup> )	Air Flow (m <sup>3</sup> /min) (CFM)	Static Pressure (Pa) (inchH <sub>2</sub> O)	Noise (dB [A])	Operating Temperature Range (°C)	Life Expectancy (h)
<b>109-371</b>	100	50/60	27/25	0.33/0.25	0.65/0.64	2900/3500	5.3/6.4 187.3/226.1	147/196 0.590/0.787	47/51	-10 ~ +60	25,000
<b>109-374</b>	115			0.29/0.22	0.55/0.54						
<b>109-372</b>	200			0.16/0.13	0.33/0.32						
<b>109-373</b>	230			0.14/0.11	0.28/0.27						

### Air Flow and Static Pressure Characteristics

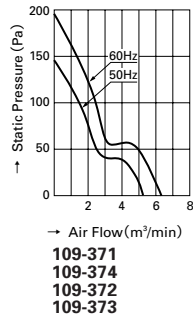

**Dimensions (unit : mm)**

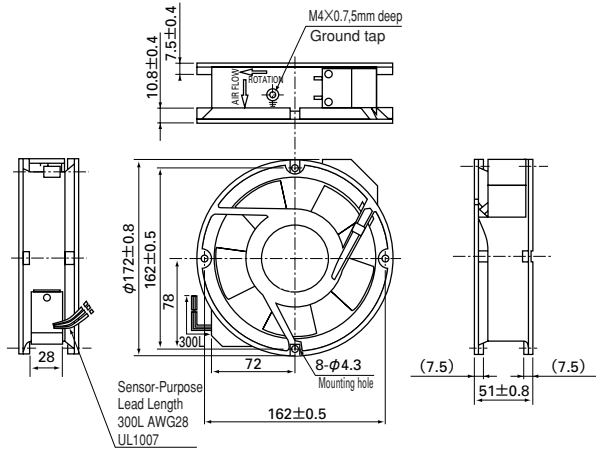

**Reference dimension of mounting holes and vent opening (unit : mm)**

Air inlet side · Air outlet side

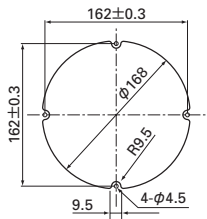

**Wiring diagram (For fan power supply)**

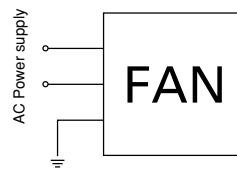

AC Fans

**Wiring diagram (Sensor Output Circuit)**

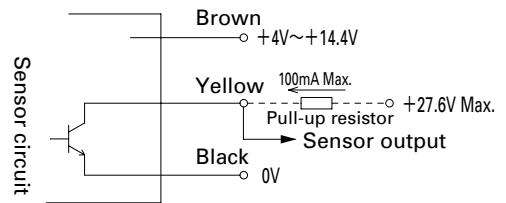

172mm



# COOLING SYSTEMS

## OPTIONS

### Finger guards • Resin finger guard

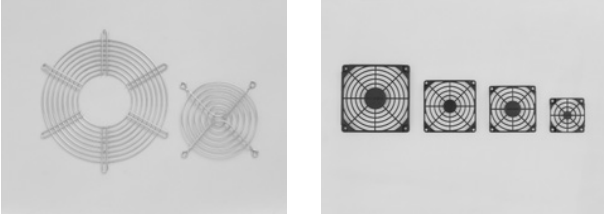

### Filter kits • Resin filter kits



### Screen kits

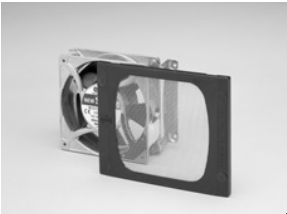

### Plug cord



### Connector • Thermistor • Alarm IC

Options

Finger guards  
Resin finger guard

Filter kits  
Resin filter kits

Screen kits

Plug cord

Connector  
Thermistor  
Alarm IC

# Finger guards

Surface treatment	color
Nickel-chrome plating	silver
Cation electropainting	black

*	Either outlet and inlet
**	Outlet side
***	Inlet side

## Dimensions (unit : mm)

### ● 40×40mm type\*

Model : 109-059 Surface treatment : Nickel-chrome plating

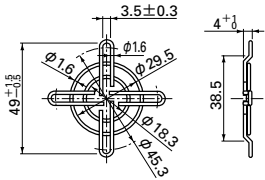

### ● 52×52mm type\*\*

Model : 109-149 Surface treatment : Nickel-chrome plating

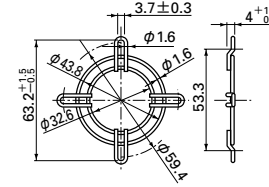

### ● 52×52mm type\*

Model : 109-149E Surface treatment : Nickel-chrome plating

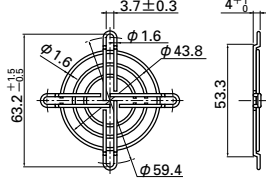

### ● 60×60mm type\*

Model : 109-139E Surface treatment : Nickel-chrome plating  
Model : 19-139H Surface treatment : Cation electropainting

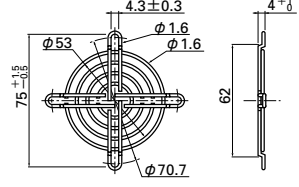

### ● 80×80mm type\*\*

Model : 109-049C Surface treatment : Nickel-chrome plating

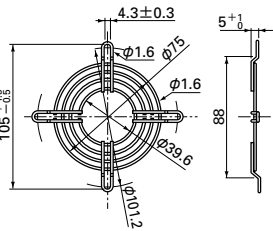

### ● 80×80mm type\*

Model : 109-049E Surface treatment : Nickel-chrome plating  
Model : 109-049H Surface treatment : Cation electropainting

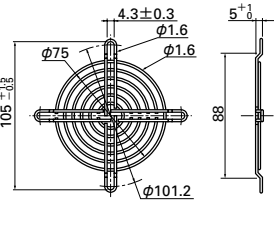

### ● 92×92mm type\*\*

Model : 109-090C Surface treatment : Nickel-chrome plating

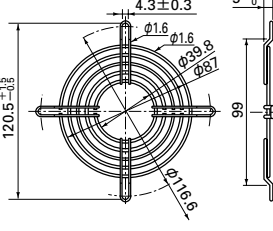

### ● 92×92mm type\*

Model : 109-090E Surface treatment : Nickel-chrome plating  
Model : 109-090H Surface treatment : Cation electropainting

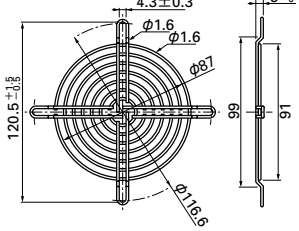

### ● 120×120mm type\*\*

Model : 109-019C Surface treatment : Nickel-chrome plating  
Model : 109-019H Surface treatment : Cation electropainting

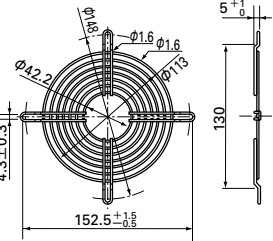

### ● 120×120mm type\*

Model : 109-019E Surface treatment : Nickel-chrome plating  
Model : 109-019K Surface treatment : Cation electropainting

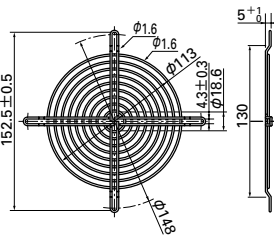

### ● 127×127mm type\*

Model : 109-722 Surface treatment : Nickel-chrome plating

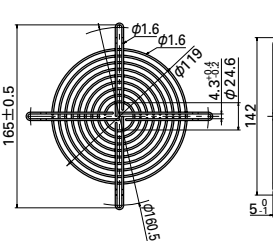

### ● 127×127mm type\*\*

Model : 109-723 Surface treatment : Nickel-chrome plating

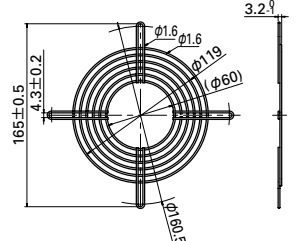

### ● 140×140mm type\*

Model : 109-719 Surface treatment : Nickel-chrome plating  
Model : 109-719H Surface treatment : Cation electropainting

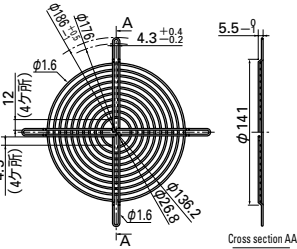

### ● 160×160mm type\*

Model : 109-619E Surface treatment : Nickel-chrome plating

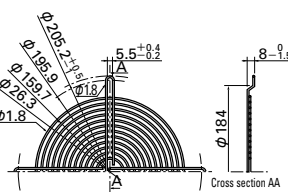

### ● 160×160mm type\*\*

Model : 109-620 Surface treatment : Nickel-chrome plating

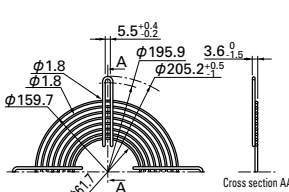

### ● φ172mm type\*\*

Model : 109-319 Surface treatment : Nickel-chrome plating

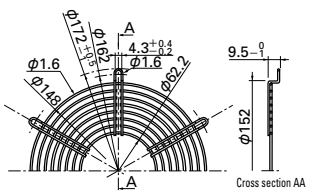

### ● φ172mm type\*

Model : 109-319E Surface treatment : Nickel-chrome plating  
Model : 109-319H Surface treatment : Cation electropainting

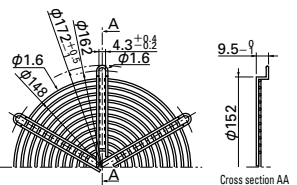

### ● φ172mm type\*\*

Model : 109-320 Surface treatment : Nickel-chrome plating

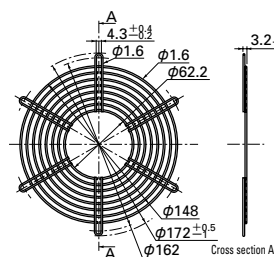

### ● φ200mm type\*

Model : 109-720 Surface treatment : Nickel-chrome plating  
Model : 109-720H Surface treatment : Cation electropainting

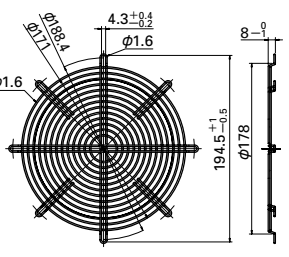

### ● φ200mm type\*\*

Model : 109-721 Surface treatment : Nickel-chrome plating  
Model : 109-721H Surface treatment : Cation electropainting

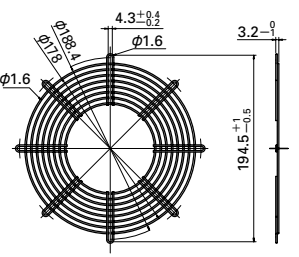

Options

Finger guards  
Resin finger guard



# Resin finger guards

Dimensions (unit : mm)

## 60mm type

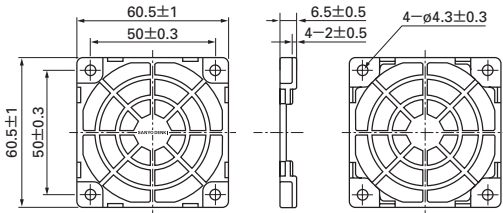

Model 109-1003G

## 80mm type

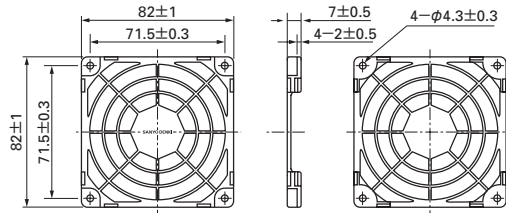

Model 109-1002G

## 92mm type

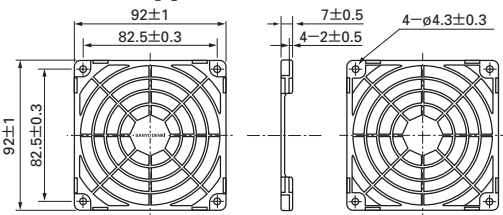

Model 109-1001G

## 120mm type

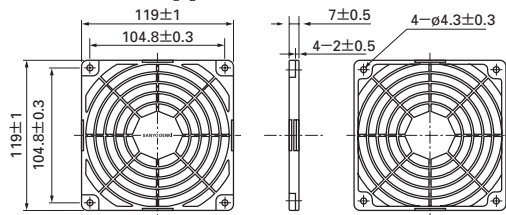

Model 109-1000G

Material

Frame : (SPS+PS alloy) Resin

UL File No.E48268 94V-0

Options

Finger guards  
Resin finger guard

## Air Flow and Static Pressure Characteristics

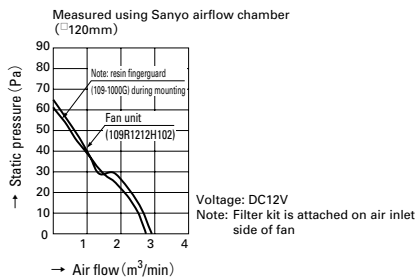

Plastic finger guards are placed on both the intake and exhaust sides of the fan.  
No nuts or screws for use in attachment included.

## Mounting example

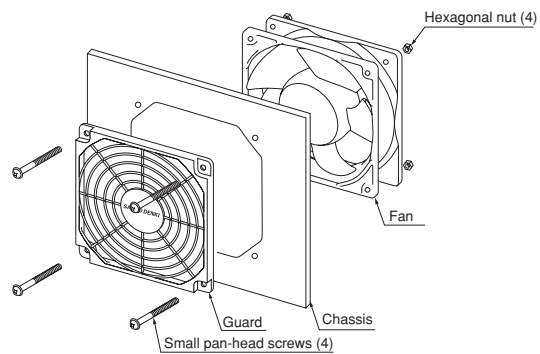

# Filter kits

Applicable models : AC Fan 120×120mm type

## Dimensions (unit : mm)

Model :109-018

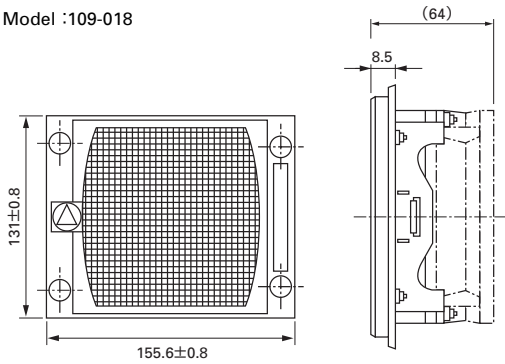

### Material

Steel Wire Mesh : Stainless 16-mesh nets in 3 layers

Cover : Resin

Metal fittings : Steel (chromate-plated)

## Air Flow and Static Pressure characteristics (by SANYO airflow chamber)

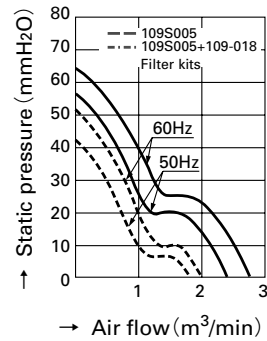

## Reference Dimensions Of Mounting Holes (in : mm)

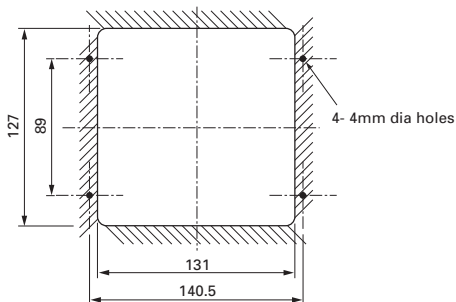

## Reference Diagram For Mounting

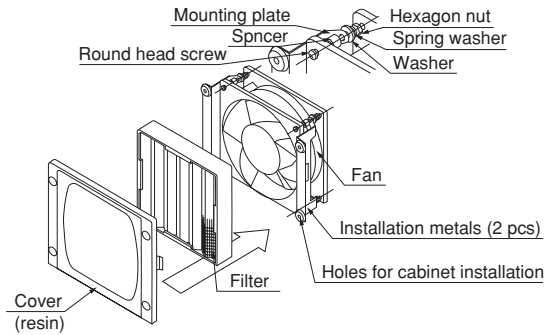

The parts shown in the installation diagram (nuts, washers, and screws) are included.

# Resin filter kits

Applicable models : AC Fan, DC Fan

Dimensions (unit : mm)

## 60mm type

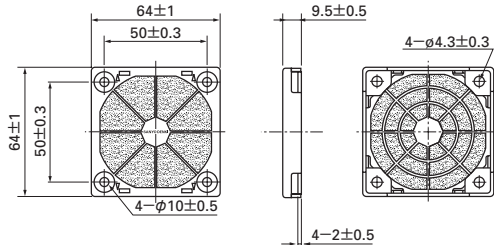

Model	109-1003F13	13PPI*
	109-1003F20	20PPI*
	109-1003F30	30PPI*
	109-1003F40	40PPI*

## 80mm type

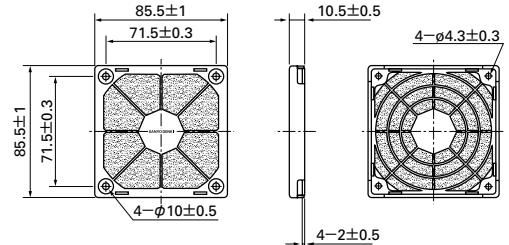

Model	109-1002F13	13PPI*
	109-1002F20	20PPI*
	109-1002F30	30PPI*
	109-1002F40	40PPI*

## 92mm type

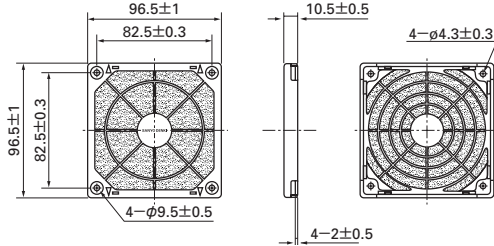

Model	109-1001F13	13PPI*
	109-1001F20	20PPI*
	109-1001F30	30PPI*
	109-1001F40	40PPI*

## 120mm type

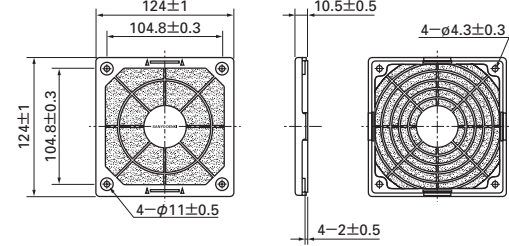

Model	109-1000F13	13PPI*
	109-1000F20	20PPI*
	109-1000F30	30PPI*
	109-1000F40	40PPI*

### Material

Guard,cover : (SPS+PS alloy) Resin  
UL File No.E48268 94V-0  
Filter : Polyurethane foam  
UL File No.E74916(S) 94HF-1

### PPI

Particles Per Inch : Indicates the number of holes per inch.  
Note that the higher the number, the finer the grain of the sponge.

### Replacement filter (5 sheets each)

□60mm	□80mm	□92mm	□120mm
109-1003M13	109-1002M13	109-1001M13	109-1000M13
13PPI	13PPI	13PPI	13PPI
109-1003M20	109-1002M20	109-1001M20	109-1000M20
20PPI	20PPI	20PPI	20PPI
109-1003M30	109-1002M30	109-1001M30	109-1000M30
30PPI	30PPI	30PPI	30PPI
109-1003M40	109-1002M40	109-1001M40	109-1000M40
40PPI	40PPI	40PPI	40PPI

Options

Filter kits  
Resin filter kits

## Performance comparison of air flow vs static pressure

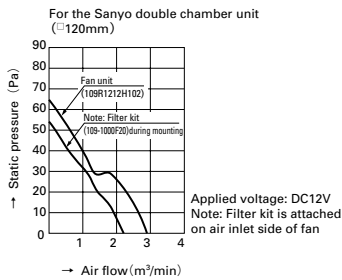

## Reference Diagram For Mounting

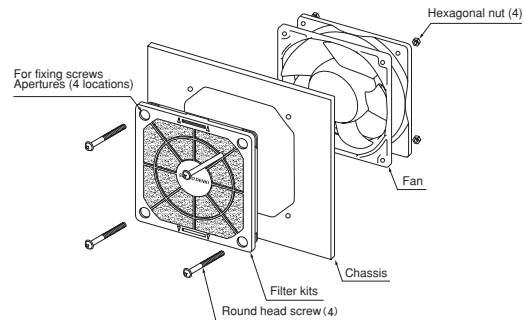

Although the filter kit is composed of 3 components, including a guard, a filter and a cover, it is delivered as a finished product at delivery, saving assembly time when mounting. The filter and cover can be easily removed from the guard with one touch, removing the need for fan removal when undertaking maintenance, such as for cleaning or replacements. As cooling ability decreases with filter contamination due to clogging, regular replacements are recommended. No nuts or screws for use in attachment included.

# Screen kits

Applicable models : AC Fan 120×120mm type

## Dimensions (unit : mm)

Model :109-020

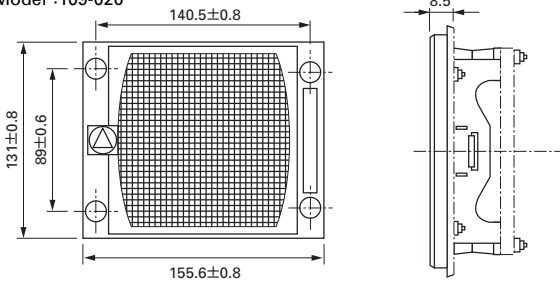

### Material

Steel Wire Mesh : Stainless 16-mesh nets in 3 layers

Cover : Resin

Metal fittings : Steel (chromate-plated)

## Air Flow and Static Pressure characteristics (by SANYO airflow chamber)

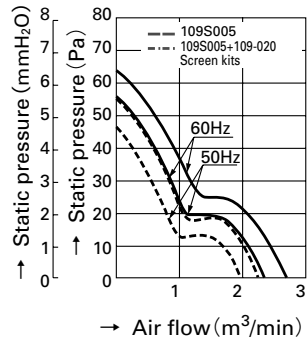

## Reference Dimensions Of Mounting Holes (in : mm)

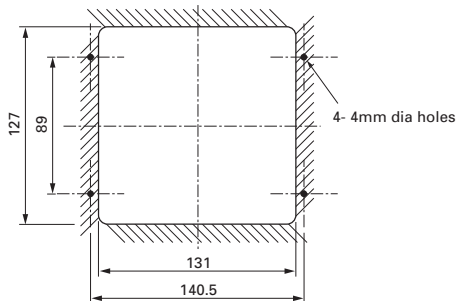

## Reference Diagram For Mounting

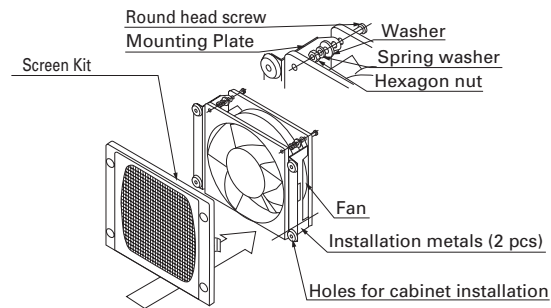

### Screen kits

The parts shown in the installation diagram (nuts, washers, and screws) are included.



Options

# AC Fan Plug cord

Dimensions (unit : mm)

## PRODUCTS COMPLIANT WITH ELECTRICAL APPLIANCE AND MATERIAL SAFETY LAW

● **Model No. : 489-008-L10/489-008-L21/489-008-L35**  
For : 80×80×42mm

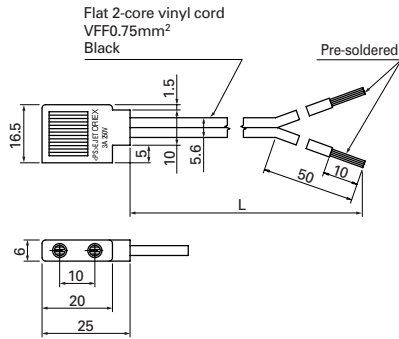

● **Model No. : 489-016-L10/489-016-L21**  
For : 120×120×25mm  
92×92×25mm  
80×80×25mm  
80×80×38mm

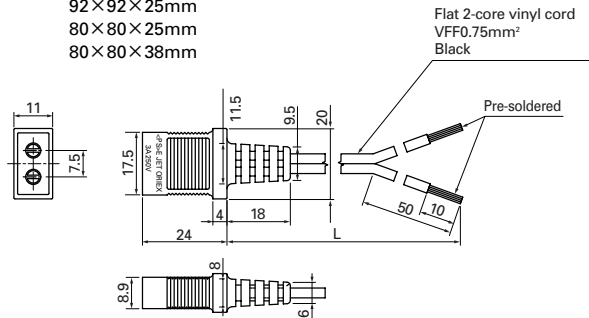

● **Model No. : 489-006-L10/489-006-L21**  
For : 120×120×38mm

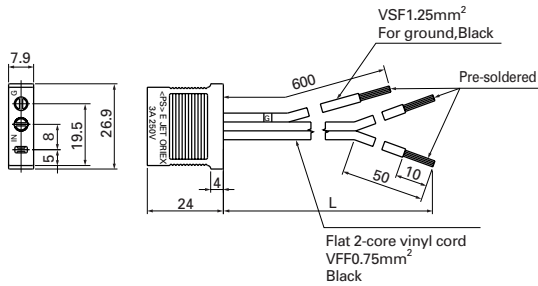

Plug cord

## POWER CORD LENGTH

Model	Power cord length(mm)
—L10	1000
—L21	2100
—L35	3500

**Dimensions (unit : mm)**

**UL/CSA CERTIFIED**

● **Model No. : 489-007-L10/489-007-L21**  
 UL FILE No.E50197 CSA FILE No.LR67048  
 For : 120×120×38mm

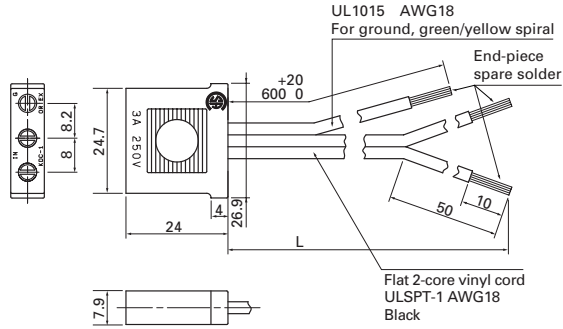

● **Model No. : 489-047-L10/489-047-L21**  
 UL FILE No.E50197 CSA FILE No.LR67048  
 For : 120×120×25mm  
 92×92×25mm  
 80×80×25mm  
 80×80×38mm

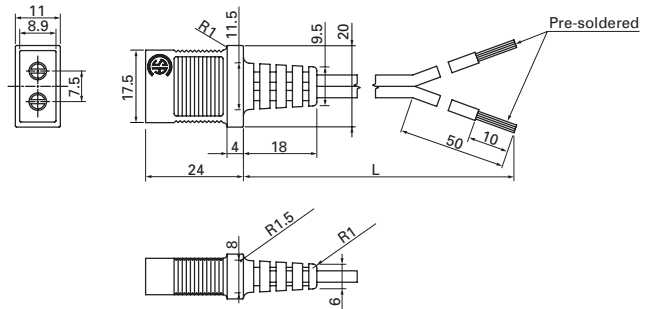

● **Model No. : 489-084-L10/489-084-L21**  
 UL FILE No.E50197 CSA FILE No.LR67048  
 L-shaped  
 For :  $\phi$  172mm×51mm  
 160×160×51mm

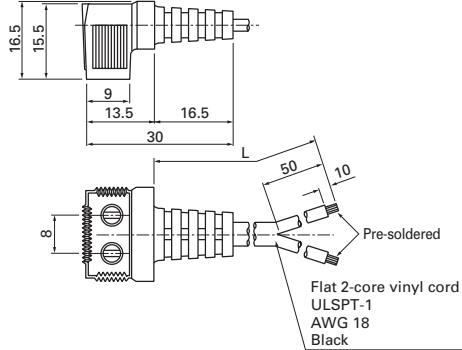

● **Model No. : 489-086-L10/489-086-L21**  
 UL FILE No.E50197 CSA FILE No.LR67048  
 straight  
 For :  $\phi$  172mm×51mm  
 160×160×51mm

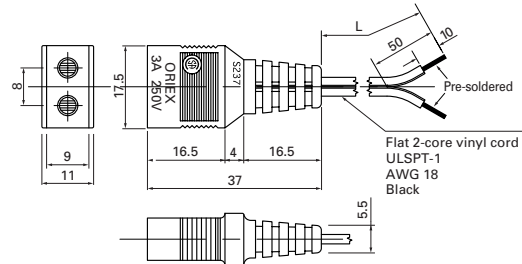

**POWER CORD LENGTH**

Model	Power cord length(mm)
—L10	1000
—L21	2100
—L35	3500

Options

Plug cord

# Recommended connectors for DC fans

Brand	Housing model number	Contact model number
Hirose	DF3AA- *EP-2C	DF3-EP2428PCF
	DF1B- *ES-2.5RC	DF1B-2428SCF
Tyco Electronics AMP.	179228- *	179227- 1
	171822- *	170262- 1
Japan Solderless Terminals	PHR- *	SPH-002T-P0.5S
	XHP- *	SXH-001T-P0.6
	SMR-0*V-N	SYM-001T-0.6
	EHR- *	SEH-001T-P0.6
	H*P-SHF-AA	SHF-001T-0.8BS
Molex Inc. (Japan)	5051- *	5159T
	5264- *	5263PBT
	51030-0*30	50084-8014
	51065-0*00	50212-8000
	5557-0*R	5556 *
	5559-0*P	5558 *
Japan Aviation Electronics Industry	IL-S- *S-S2C2-S	IL-S-C2-S-10000
	IL-G- *S-S3C2-SA	IL-G-C2-SC-10000,
	IL- *S-S3L- (N)	IL-C2-1-10000, IL-C2-10000

Note 1 : (\*) indicates number of poles (ex : -2 or -02 for two poles, -3 or -03 for three poles).

Note 2 : The specifications in this table are for reference purposes only. When selecting, please check catalogs of each brand.

# Thermistor

Model : 169-002

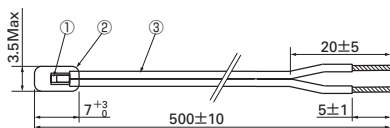

Connector  
Thermistor  
Alarm IC

Number	Name	Standards, materials, etc.
①	Thermistor	Chip
②	Insulated cord	Epoxy resin
③	Lead	UL2555 CSA TR-64 AWG#28 (blue)

Item		Spec
2-1	Resistance	R25 6.8 KΩ±3%
2-2	B constant	25/50 3950 K±2%
2-3	Maximum rated power	188mW (25°C under still air)
2-4	Insulation resistance	100MΩ or more (500 VDC megger)
2-5	Dielectric strength	No problem (1,500 VAC, 1 minute)
2-6	Operating temperature range	-30°C ~ +80°C
2-7	Storage temperature range	-40°C ~ +100°C

This thermistor part number is 159-682-86003 (manufactured by Hokuriku Electric Industry). For details, contact Tokyo Office at 03-3722-1341.



# IC L8730 for DC fan alarm

## Characteristics

### Startup delay

L8730 doesn't output signal until fan normally runs after start-up

### Output current

10mA max.(sink/Open drain output)

The output with latch is also available

### Input type

Single input: L8730 can input digital signal of Vov and GND

### Noise margin

Malfunction-protective circuit in embedded

### Supply voltage range

+5V±0.5V

## Dimensions

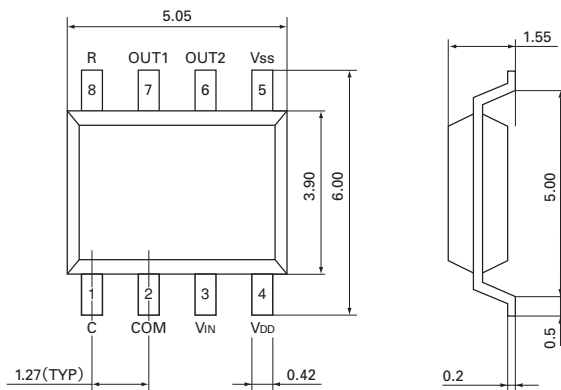

Options

## Application

Use it for your receiving circuit of a our DC fan (with a pulse sensor).

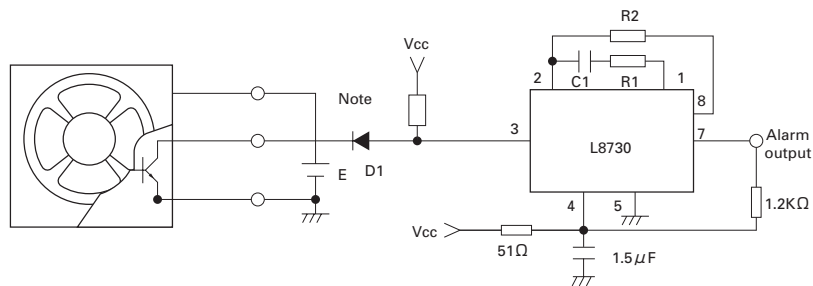

E: Power supply for fan drive circuit  
 Vcc : 5V±0.5V  
 At normal speed [H]: Vcc  
 At abnormal speed [L]: 0.5V max

Note: Insert a D1 in case of E > Vcc.

Connector  
 Thermistor  
 Alarm IC

Trip speed min <sup>-1</sup>	C1 PF	R1 KΩ	R2 KΩ	Startup delay
850	1,100	22	68	19.5sec
1,700	560	22	68	10sec
2,700	330	22	68	6sec



# **Model No. index**

## DC Fans

Model No.	Size	Thick	Page
109P0405H902	40×40mm	10	36
109P0405M902	40×40mm	10	36
109P0412H902	40×40mm	10	36
109P0412M902	40×40mm	10	36
109P0405H702	40×40mm	15	36
109P0405M702	40×40mm	15	36
109P0412H702	40×40mm	15	36
109P0412M702	40×40mm	15	36
109P0412S702	40×40mm	15	36
109P0424H702	40×40mm	15	36
109P0405F602	40×40mm	20	38
109P0405H602	40×40mm	20	38
109P0405M602	40×40mm	20	38
109P0412F602	40×40mm	20	38
109P0412G602	40×40mm	20	38
109P0412H602	40×40mm	20	38
109P0412M602	40×40mm	20	38
109P0424F602	40×40mm	20	38
109P0424H602	40×40mm	20	38
109P0405F302	40×40mm	28	39
109P0405F3023	40×40mm	28	42
109P0405H302	40×40mm	28	39
109P0405H3023	40×40mm	28	42
109P0412B302	40×40mm	28	39
109P0412B3023	40×40mm	28	42
109P0412F302	40×40mm	28	39
109P0412F3023	40×40mm	28	42
109P0412G302	40×40mm	28	39
109P0412G3023	40×40mm	28	42
109P0412H302	40×40mm	28	39
109P0412H3023	40×40mm	28	42
109P0412J3023	40×40mm	28	42
109P0412K3023	40×40mm	28	42
109P0412M302	40×40mm	28	39
109P0412M3023	40×40mm	28	42
109P0424B302	40×40mm	28	39
109P0424B3023	40×40mm	28	42
109P0424F302	40×40mm	28	39
109P0424F3023	40×40mm	28	42
109P0424G302	40×40mm	28	39
109P0424G3023	40×40mm	28	42
109P0424H302	40×40mm	28	39
109P0424H3023	40×40mm	28	42
109P0424J3023	40×40mm	28	42
9GV0412G302(3021)	40×40mm	28	40
9GV0412J302(3021)	40×40mm	28	40
9CR0412H502	40×40mm	56	46
9CR0412S502	40×40mm	56	46
9CRA0412G502	40×40mm	56	44
9CRA0412J502	40×40mm	56	44
109P0505M702	52×52mm	15	48
109P0512A702	52×52mm	15	48
109P0512H702	52×52mm	15	48
109P0512M702	52×52mm	15	48
109P0524H702	52×52mm	15	48
109P0524M702	52×52mm	15	48
109P0605H702	60×60mm	15	50
109P0605M702	60×60mm	15	50
109P0612H702	60×60mm	15	50
109P0612M702	60×60mm	15	50
109P0612S702	60×60mm	15	50
109P0624H702	60×60mm	15	50
109P0624M702	60×60mm	15	50
109P0612H602	60×60mm	20	50
109P0612M602	60×60mm	20	50
109P0612W602	60×60mm	20	50
109P0624H602	60×60mm	20	50
109P0624M602	60×60mm	20	50
109P0624W602	60×60mm	20	50
109P0648H602	60×60mm	20	50
109R0605F402(4021)	60×60mm	25	51
109R0605H402(4021)	60×60mm	25	51
109R0605M402(4021)	60×60mm	25	51

## DC Fans

Model No.	Size	Thick	Page
109R0612D402(4021)	60×60mm	25	51
109R0612F402(4021)	60×60mm	25	51
109R0612G402(4021)	60×60mm	25	51
109R0612H402(4021)	60×60mm	25	51
109R0612J402(4021)	60×60mm	25	51
109R0612M402(4021)	60×60mm	25	51
109R0612S402(4021)	60×60mm	25	51
109R0624D402(4021)	60×60mm	25	51
109R0624F402(4021)	60×60mm	25	51
109R0624G402(4021)	60×60mm	25	51
109R0624H402(4021)	60×60mm	25	51
109R0624J402(4021)	60×60mm	25	51
109R0624M402(4021)	60×60mm	25	51
109R0624S402(4021)	60×60mm	25	51
109R0648G402(4021)	60×60mm	25	51
109R0648H402(4021)	60×60mm	25	51
109R0648J402(4021)	60×60mm	25	51
9A0612F402(4021)	60×60mm	25	90
9A0612G402(4021)	60×60mm	25	90
9A0612H402(4021)	60×60mm	25	90
9A0612M402(4021)	60×60mm	25	90
9A0612S402(4021)	60×60mm	25	90
9A0624F402(4021)	60×60mm	25	90
9A0624G402(4021)	60×60mm	25	90
9A0624H402(4021)	60×60mm	25	90
9A0624M402(4021)	60×60mm	25	90
9A0624S402(4021)	60×60mm	25	90
9G0612G102(1021)	60×60mm	38	52
9G0612S102(1021)	60×60mm	38	52
9G0624G102(1021)	60×60mm	38	52
9G0624S102(1021)	60×60mm	38	52
9G0648G102(1021)	60×60mm	38	52
9G0648S102(1021)	60×60mm	38	52
109P0812H702	80×80mm	15	54
109P0812M702	80×80mm	15	54
109P0824H702	80×80mm	15	54
109P0824M702	80×80mm	15	54
109P0812H602	80×80mm	20	54
109P0812M602	80×80mm	20	54
109P0824H602	80×80mm	20	54
109P0824M602	80×80mm	20	54
109R0805F402(4021)	80×80mm	25	54
109R0805M402(4021)	80×80mm	25	54
109R0812F402(4021)	80×80mm	25	54
109R0812G402(4021)	80×80mm	25	54
109R0812H402(4021)	80×80mm	25	54
109R0812L402(4021)	80×80mm	25	54
109R0812M402(4021)	80×80mm	25	54
109R0812S402(4021)	80×80mm	25	54
109R0824F402(4021)	80×80mm	25	54
109R0824G402(4021)	80×80mm	25	54
109R0824H402(4021)	80×80mm	25	54
109R0824L402(4021)	80×80mm	25	54
109R0824M402(4021)	80×80mm	25	54
109R0824S402(4021)	80×80mm	25	54
109R0848K402(4021)	80×80mm	25	54
109R0848S402(4021)	80×80mm	25	54
9A0812F402(4021)	80×80mm	25	92
9A0812G402(4021)	80×80mm	25	92
9A0812H402(4021)	80×80mm	25	92
9A0812L402(4021)	80×80mm	25	92
9A0812M402(4021)	80×80mm	25	92
9A0812S402(4021)	80×80mm	25	92
9A0824F402(4021)	80×80mm	25	92
9A0824G402(4021)	80×80mm	25	92
9A0824H402(4021)	80×80mm	25	92
9A0824L402(4021)	80×80mm	25	92
9A0824M402(4021)	80×80mm	25	92
9A0824S402(4021)	80×80mm	25	92
109P0812A202(2021)	80×80mm	32	55
109P0812H202(2021)	80×80mm	32	55
109P0812M202(2021)	80×80mm	32	55
109P0824A202(2021)	80×80mm	32	55

## DC Fans

Model No.	Size	Thick	Page
109P0824H202(2021)	80×80mm	32	55
109P0824M202(2021)	80×80mm	32	55
109P0848H202(2021)	80×80mm	32	55
9G0812G102(1021)	80×80mm	38	56
9G0812H102(1021)	80×80mm	38	56
9G0824G102(1021)	80×80mm	38	56
9G0824H102(1021)	80×80mm	38	56
9G0848G102(1021)	80×80mm	38	56
9G0848H102(1021)	80×80mm	38	56
109P0912F402(4021)	92×92mm	25	58
109P0912H402(4021)	92×92mm	25	58
109P0912L402(4021)	92×92mm	25	58
109P0912M402(4021)	92×92mm	25	58
109P0912W402(4021)	92×92mm	25	58
109P0924F402(4021)	92×92mm	25	58
109P0924H402(4021)	92×92mm	25	58
109P0924L402(4021)	92×92mm	25	58
109P0924M402(4021)	92×92mm	25	58
109P0924W402(4021)	92×92mm	25	58
109P0948H402(4021)	92×92mm	25	58
9A0912F402(4021)	92×92mm	25	94
9A0912G402(4021)	92×92mm	25	94
9A0912H402(4021)	92×92mm	25	94
9A0912L402(4021)	92×92mm	25	94
9A0912M402(4021)	92×92mm	25	94
9A0912S402(4021)	92×92mm	25	94
9A0924F402(4021)	92×92mm	25	94
9A0924G402(4021)	92×92mm	25	94
9A0924H402(4021)	92×92mm	25	94
9A0924L402(4021)	92×92mm	25	94
9A0924M402(4021)	92×92mm	25	94
9A0924S402(4021)	92×92mm	25	94
9G0912A202(2021)	92×92mm	32	59
9G0912H202(2021)	92×92mm	32	59
9G0912M202(2021)	92×92mm	32	59
9G0912S202(2021)	92×92mm	32	59
9G0924A202(2021)	92×92mm	32	59
9G0924H202(2021)	92×92mm	32	59
9G0924M202(2021)	92×92mm	32	59
9G0924S202(2021)	92×92mm	32	59
9G0948A202(2021)	92×92mm	32	59
9G0948H202(2021)	92×92mm	32	59
9G0948M202(2021)	92×92mm	32	59
9G0948S202(2021)	92×92mm	32	59
9G0912G102(1021)	92×92mm	38	60
9G0912H102(1021)	92×92mm	38	60
9G0924G102(1021)	92×92mm	38	60
9G0924H102(1021)	92×92mm	38	60
9G0948G102(1021)	92×92mm	38	60
9G0948H102(1021)	92×92mm	38	60
109P1205M402(4021)	120×120mm	25	62
109P1212F402(4021)	120×120mm	25	62
109P1212H402(4021)	120×120mm	25	62
109P1212M402(4021)	120×120mm	25	62
109P1224F402(4021)	120×120mm	25	62
109P1224H402(4021)	120×120mm	25	62
109P1224M402(4021)	120×120mm	25	62
9G1212A402(4021)	120×120mm	25	64
9G1212E402(4021)	120×120mm	25	64
9G1212F402(4021)	120×120mm	25	64
9G1212G402(4021)	120×120mm	25	64
9G1212H402(4021)	120×120mm	25	64
9G1212M402(4021)	120×120mm	25	64
9G1224A402(4021)	120×120mm	25	64
9G1224E402(4021)	120×120mm	25	64
9G1224F402(4021)	120×120mm	25	64
9G1224G402(4021)	120×120mm	25	64
9G1224H402(4021)	120×120mm	25	64
9G1224M402(4021)	120×120mm	25	64
9G1248A402(4021)	120×120mm	25	64
9G1248E402(4021)	120×120mm	25	64
9G1248F402(4021)	120×120mm	25	64
9G1248G402(4021)	120×120mm	25	64

## DC Fans

Model No.	Size	Thick	Page
9G1248H402(4021)	120×120mm	25	64
9G1248M402(4021)	120×120mm	25	64
109R1212F102(1021)	120×120mm	38	62
109R1212H102(1021)	120×120mm	38	62
109R1212M102(1021)	120×120mm	38	62
109R1212MH102(1021)	120×120mm	38	62
109R1224H102(1021)	120×120mm	38	62
109R1224M102(1021)	120×120mm	38	62
109R1224MH102(1021)	120×120mm	38	62
109R1248H102(1021)	120×120mm	38	62
109R1248M102(1021)	120×120mm	38	62
9G1212E102(1021)	120×120mm	38	66
9G1212F102(1021)	120×120mm	38	66
9G1212G102(1021)	120×120mm	38	66
9G1212H102(1021)	120×120mm	38	66
9G1212M102(1021)	120×120mm	38	66
9G1224E102(1021)	120×120mm	38	66
9G1224F102(1021)	120×120mm	38	66
9G1224G102(1021)	120×120mm	38	66
9G1224H102(1021)	120×120mm	38	66
9G1224M102(1021)	120×120mm	38	66
9G1248E102(1021)	120×120mm	38	66
9G1248F102(1021)	120×120mm	38	66
9G1248G102(1021)	120×120mm	38	66
9G1248H102(1021)	120×120mm	38	66
9G1248M102(1021)	120×120mm	38	66
9SG1212G102	120×120mm	38	68
9SG1224G102	120×120mm	38	68
9SG1248G102	120×120mm	38	68
109E1312A102	127×127mm	38	72
109E1312S102	127×127mm	38	72
109E1324A102	127×127mm	38	72
109E1324G102	127×127mm	38	72
109E1324S102	127×127mm	38	72
109E1348A102	127×127mm	38	72
109E1348G102	127×127mm	38	72
109E1348S102	127×127mm	38	72
109P1312H102(1021)	127×127mm	38	70
109P1312S102(1021)	127×127mm	38	70
109P1324H102(1021)	127×127mm	38	70
109P1324S102(1021)	127×127mm	38	70
109P1348H102(1021)	127×127mm	38	70
109P1348S102(1021)	127×127mm	38	70
109P1412H102	140×140mm	38	74
109P1412M102	140×140mm	38	74
109P1424H102	140×140mm	38	74
109P1424M102	140×140mm	38	74
109P1448H102	140×140mm	38	74
109P1448M102	140×140mm	38	74
9GV1512H502(5021)	150×150mm	50	76
9GV1512M502(5021)	150×150mm	50	76
109E4712L402	φ 172	25	78
109E4712M402	φ 172	25	78
109E4724F402	φ 172	25	78
109E4724H402	φ 172	25	78
109E4724L402	φ 172	25	78
109E4724M402	φ 172	25	78
109E4748F402	φ 172	25	78
109E4748H402	φ 172	25	78
109E4748L402	φ 172	25	78
109E4748M402	φ 172	25	78
109E4748S402	φ 172	25	78
109E1712H502	φ 172	51	84
109E1712K502	φ 172	51	84
109E1712M502	φ 172	51	84
109E1724C502	φ 172	51	84
109E1724H502	φ 172	51	84
109E1724K502	φ 172	51	84
109E1724M502	φ 172	51	84
109E1748C502	φ 172	51	84
109E1748H502	φ 172	51	84
109E1748K502	φ 172	51	84
109E1748M502	φ 172	51	84

## DC Fans

Model No.	Size	Thick	Page
109E5712H502	φ 172	51	82
109E5712K502	φ 172	51	82
109E5712M502	φ 172	51	82
109E5724C502	φ 172	51	82
109E5724H502	φ 172	51	82
109E5724K502	φ 172	51	82
109E5724M502	φ 172	51	82
109E5748C502	φ 172	51	82
109E5748H502	φ 172	51	82
109E5748K502	φ 172	51	82
109E5748M502	φ 172	51	82
9GV5724H502	φ 172	51	80
9GV5748H502	φ 172	51	80
109E2024AS002	φ 200	70	86
109E2024H002	φ 200	70	86
109E2024MH002	φ 200	70	86
109E2024S002	φ 200	70	86
9EC2024H002	φ 200	70	88
9EC2048A002	φ 200	70	88
9EC2048H002	φ 200	70	88

The numbers in () represent ribless models

## Thermal Speed Controlled Fans

Model No.	Size	Thick	Page
109P0512T7H12	52×52mm	15	100
109P0512T7H122	52×52mm	15	101
109P0612T7H12	60×60mm	15	102
109P0612T7H122	60×60mm	15	103
109P0612T6H12	60×60mm	20	102
109P0612T6H122	60×60mm	20	103
109R0612T4H12(121)	60×60mm	25	102
109R0612T4H122(123)	60×60mm	25	103
109P0812T6H12	80×80mm	20	104
109P0812T6H122	80×80mm	20	105
109R0812T4H12(121)	80×80mm	25	104
109R0812T4H122(123)	80×80mm	25	105
109P0912T4H12(121)	92×92mm	25	106
109P0912T4H122(123)	92×92mm	25	107
109P1212T4H12(121)	120×120mm	25	108
109P1212T4H122(123)	120×120mm	25	109
109R1212T1H12(121)	120×120mm	38	108
109R1212T1H122(123)	120×120mm	38	109

The numbers in () represent ribless models

## Splash Proof Fans

Model No.	Size	Thick	Page
9WP0612H402(4021)	60×60mm	25	114
9WP0624H402(4021)	60×60mm	25	114
9WP0648H402(4021)	60×60mm	25	114
109W0812F402-U	80×80mm	25	116
109W0812H402-U	80×80mm	25	116
109W0812L402-U	80×80mm	25	116
109W0812M402-U	80×80mm	25	116
109W0824F402-U	80×80mm	25	116
109W0824H402-U	80×80mm	25	116
109W0824L402-U	80×80mm	25	116
109W0824M402-U	80×80mm	25	116
109W0848H402-U	80×80mm	25	116
9WS0812F402(4021)	80×80mm	25	120
9WS0812H402(4021)	80×80mm	25	120
9WS0812M402(4021)	80×80mm	25	120
9WS0824F402(4021)	80×80mm	25	120
9WS0824H402(4021)	80×80mm	25	120
9WS0824M402(4021)	80×80mm	25	120
9WP0812H402(4021)	80×80mm	38	118
9WP0824H402(4021)	80×80mm	38	118
9WP0848S402(4021)	80×80mm	38	118
109W0912F402-U	92×92mm	25	122
109W0912H402-U	92×92mm	25	122
109W0912L402-U	92×92mm	25	122
109W0912M402-U	92×92mm	25	122
109W0924F402-U	92×92mm	25	122
109W0924H402-U	92×92mm	25	122

## Splash Proof Fans

Model No.	Size	Thick	Page
109W0924L402-U	92×92mm	25	122
109W0924M402-U	92×92mm	25	122
109W0948H402-U	92×92mm	25	122
9WS0912F402	92×92mm	25	124
9WS0912H402	92×92mm	25	124
9WS0912L402	92×92mm	25	124
9WS0912M402	92×92mm	25	124
9WS0924F402	92×92mm	25	124
9WS0924H402	92×92mm	25	124
9WS0924L402	92×92mm	25	124
9WS0924M402	92×92mm	25	124
109W1212H102-U	120×120mm	38	126
109W1212M102-U	120×120mm	38	126
109W1221H102-U	120×120mm	38	126
109W1224H102-U	120×120mm	38	126
109W1224M102-U	120×120mm	38	126
109W1248H102-U	120×120mm	38	126
109W1248M102-U	120×120mm	38	126
9WG1212E102	120×120mm	38	130
9WG1212F102	120×120mm	38	130
9WG1212G102	120×120mm	38	130
9WG1212H102	120×120mm	38	130
9WG1212J102	120×120mm	38	130
9WG1212M102	120×120mm	38	130
9WG1224E102	120×120mm	38	130
9WG1224F102	120×120mm	38	130
9WG1224G102	120×120mm	38	130
9WG1224H102	120×120mm	38	130
9WG1224J102	120×120mm	38	130
9WG1224M102	120×120mm	38	130
9WG1248E102	120×120mm	38	130
9WG1248F102	120×120mm	38	130
9WG1248G102	120×120mm	38	130
9WG1248H102	120×120mm	38	130
9WG1248J102	120×120mm	38	130
9WG1248M102	120×120mm	38	130
9WP1212H102(1021)	120×120mm	38	128
9WP1224H102(1021)	120×120mm	38	128
9WP1248H102(1021)	120×120mm	38	128
9WS1212H102(1021)	120×120mm	38	132
9WS1212M102(1021)	120×120mm	38	132
9WS1224H102(1021)	120×120mm	38	132
9WS1224M102(1021)	120×120mm	38	132
9WS1248H102(1021)	120×120mm	38	132
9WS1248M102(1021)	120×120mm	38	132
109W1412H102-U	140×140mm	38	134
109W1412M102-U	140×140mm	38	134
109W1424H102-U	140×140mm	38	134
109W1424M102-U	140×140mm	38	134
109W1448H102-U	140×140mm	38	134
109W1448M102-U	140×140mm	38	134
9WB1412H502	140×140mm	51	134
9WB1412M502	140×140mm	51	134
9WB1412S502	140×140mm	51	134
9WB1424H502	140×140mm	51	134
9WB1424M502	140×140mm	51	134
9WB1448H502	140×140mm	51	134
9WB1448S502	140×140mm	51	134

The numbers in () represent ribless models

## Oil Proof Fans

Model No.	Size	Thick	Page
9WF0424H602	40×40mm	20	138
9WF0624H402	60×60mm	25	140
9WF1224H102	120×120mm	38	142

**Long Life Fans**

Model No.	Size	Thick	Page
9L0412H302	40×40mm	28	146
9L0412J302	40×40mm	28	146
9L0412M302	40×40mm	28	146
109L0612G402	60×60mm	25	148
109L0612F402	60×60mm	25	148
109L0612H402	60×60mm	25	148
109L0612M402	60×60mm	25	148
109L0612S402	60×60mm	25	148
109L0624F402	60×60mm	25	148
109L0624H402	60×60mm	25	148
109L0624M402	60×60mm	25	148
109L0624S402	60×60mm	25	148
109L0648G401	60×60mm	25	148
109L0648H402	60×60mm	25	148
109L0812F402	80×80mm	25	150
109L0812H402	80×80mm	25	150
109L0812L402	80×80mm	25	150
109L0812M402	80×80mm	25	150
109L0812S402	80×80mm	25	150
109L0824F402	80×80mm	25	150
109L0824H402	80×80mm	25	150
109L0824L402	80×80mm	25	150
109L0824M402	80×80mm	25	150
109L0824S402	80×80mm	25	150
109L0848H402	80×80mm	25	150
109L0912F402	92×92mm	25	152
109L0912H402	92×92mm	25	152
109L0912L402	92×92mm	25	152
109L0912M402	92×92mm	25	152
109L0912S402	92×92mm	25	152
109L0924F402	92×92mm	25	152
109L0924H402	92×92mm	25	152
109L0924L402	92×92mm	25	152
109L0924M402	92×92mm	25	152
109L0948C402	92×92mm	25	152
109L0948H402	92×92mm	25	152
109L1212H102	120×120mm	38	154
109L1212M102	120×120mm	38	154
109L1221H102	120×120mm	38	154
109L1224H102	120×120mm	38	154
109L1224M102	120×120mm	38	154
109L1248H102	120×120mm	38	154
109L1248M102	120×120mm	38	154
9GL1212E102	120×120mm	38	156
9GL1212F102	120×120mm	38	156
9GL1212G102	120×120mm	38	156
9GL1212H102	120×120mm	38	156
9GL1212J102	120×120mm	38	156
9GL1212M102	120×120mm	38	156
9GL1224E102	120×120mm	38	156
9GL1224F102	120×120mm	38	156
9GL1224G102	120×120mm	38	156
9GL1224H102	120×120mm	38	156
9GL1224J102	120×120mm	38	156
9GL1224M102	120×120mm	38	156
9GL1248E102	120×120mm	38	156
9GL1248F102	120×120mm	38	156
9GL1248G102	120×120mm	38	156
9GL1248H102	120×120mm	38	156
9GL1248J102	120×120mm	38	156
9GL1248M102	120×120mm	38	156
9LB1212H102	120×120mm	38	154
9LB1212M102	120×120mm	38	154
9LB1224H102	120×120mm	38	154
9LB1224M102	120×120mm	38	154
9LB1248H102	120×120mm	38	154
9LB1248M102	120×120mm	38	154
109L1412H102	140×140mm	38	158
109L1412M102	140×140mm	38	158
109L1424H102	140×140mm	38	158
109L1424M102	140×140mm	38	158
109L1448H102	140×140mm	38	158
109L1448M102	140×140mm	38	158

**Long Life Fans**

Model No.	Size	Thick	Page
9LB1412H502	140×140mm	51	158
9LB1412M502	140×140mm	51	158
9LB1412S502	140×140mm	51	158
9LB1424H502	140×140mm	51	158
9LB1424M502	140×140mm	51	158
9LB1424S502	140×140mm	51	158
9LB1448H502	140×140mm	51	158
9LB1448M502	140×140mm	51	158
9LB1448S502	140×140mm	51	158
109L1712H502	φ 172	51	162
109L1712M502	φ 172	51	162
109L1724H502	φ 172	51	162
109L1724M502	φ 172	51	162
109L1748H502	φ 172	51	162
109L1748M502	φ 172	51	162
109L5712H502	φ 172	51	160
109L5712M502	φ 172	51	160
109L5724H502	φ 172	51	160
109L5724M502	φ 172	51	160
109L5748H502	φ 172	51	160
109L5748M502	φ 172	51	160

**Blowers**

Model No.	Size	Thick	Page
109BC12FA7	52	15	166
109BC12GA7	52	15	166
109BC12HA7	52	15	166
109BC12MA7	52	15	166
109BC24FA7	52	15	166
109BC24GA7	52	15	166
109BC24HA7	52	15	166
9BD12FA6	76	20	168
9BD12HA6	76	20	168
9BD12SA6	76	20	168
9BD24FA6	76	20	168
9BD24HA6	76	20	168
9BD24SA6	76	20	168
109BD12GA4	76	25	168
109BD12HA4	76	25	168
109BD12MA4	76	25	168
109BD24GA4	76	25	168
109BD24HA4	76	25	168
109BD24MA4	76	25	168
109BD12FA2	76	30	170
109BD12HA2	76	30	170
109BD12MA2	76	30	170
109BD24FA2	76	30	170
109BD24HA2	76	30	170
109BD24MA2	76	30	170
109BE12GA2	94	30	172
109BE12HA2	94	30	172
109BE12MA2	94	30	172
109BE24GA2	94	30	172
109BE24HA2	94	30	172
109BE24MA2	94	30	172
109BM12GA2	97	33	176
109BM12HA2	97	33	176
109BM12MA2	97	33	176
109BM24GA2	97	33	176
109BM24HA2	97	33	176
109BM24MA2	97	33	176
9BAM12FA2	97	33	174
9BAM12GA2	97	33	174
9BAM12HA2	97	33	174
9BAM12SA2	97	33	174
9BAM24FA2	97	33	174
9BAM24GA2	97	33	174
9BAM24HA2	97	33	174
9BAM24SA2	97	33	174
109BF12HA2	120	32	178
109BF12MA2	120	32	178
109BF24HA2	120	32	178
109BF24MA2	120	32	178

## Blowers

Model No.	Size	Thick	Page
109BJ12HA2	127	32	180
109BJ12MA2	127	32	180
109BJ24HA2	127	32	180
109BJ24MA2	127	32	180
9BN12FA1	150	40	182
9BN12HA1	150	40	182
9BN24FA1	150	40	182
9BN24HA1	150	40	182
109BG12HA1	160	40	184
109BG12MA1	160	40	184
109BG24HA1	160	40	184
109BG24MA1	160	40	184

## Centrifugal Fans

Model No.	Size	Thick	Page
9TR48HA0	φ220	71	188

## CPU Coolers

Model No.	Size	Thick	Page
9G0912P2E012			192
9G0912PT2E012			192
109X9112PT0H016	φ90	62.6	194
109X9212PT0H016	φ90	62.6	196
109X9912T0D516	95×90	51	198
109X9912T0S016	95×90	51	200
109X9912S0016	95×90	51	200
109X9812T0H016	95×90	62.5	202
109X9812H0016	95×90	62.5	202
109X9412G4016	83.3×87.2	25	204
9H9912G5516	70×83.3	54.5	206
109X9412S1016	68.5×83.3	45	208
9H9912G5016	70×88.9	54.5	210
109X9612S5016	67.3×88.9	53.5	212
109X7612H1176	67.3×68	45	214
109X7412S4016	67.3×79	24	216
109X6512A2016	50.8×64	31	218
109-LC1-001	199.5×170	78.6	220

## AC Fans

Model No.	Size	Thick	Page
109-180	60×60mm	28	224
109-183	60×60mm	28	224
109-130	60×60mm	38	224
109-133	60×60mm	38	224
109-210	80×80mm	20	226
109-213	80×80mm	20	226
109S050	80×80mm	25	226
109S051	80×80mm	25	226
109S053	80×80mm	25	226
109S054	80×80mm	25	226
☆109S030	80×80mm	25	226
☆109S031	80×80mm	25	226
☆109S033	80×80mm	25	226
☆109S034	80×80mm	25	226
109-150	80×80mm	38	227
109-151	80×80mm	38	227
109-153	80×80mm	38	227
109-154	80×80mm	38	227
109-040UL	80×80mm	42	228
109-041UL	80×80mm	42	228
109-043UL	80×80mm	42	228
109-044UL	80×80mm	42	228
※109-033UL	80×80mm	42	228
※109-047UL	80×80mm	42	228
109S091	92×92mm	25	230
109S092	92×92mm	25	230
109S093	92×92mm	25	230
109S094	92×92mm	25	230
109S491	92×92mm	25	240
109S492	92×92mm	25	240
109S493	92×92mm	25	240

## AC Fans

Model No.	Size	Thick	Page
109S494	92×92mm	25	240
☆109S095	92×92mm	25	230
☆109S495	92×92mm	25	240
※109S096	92×92mm	25	230
※109S192	92×92mm	25	230
※109S193	92×92mm	25	230
※109S194	92×92mm	25	230
※109S496	92×92mm	25	240
109S084	120×120mm	25	232
109S085	120×120mm	25	232
109S087	120×120mm	25	232
109S088	120×120mm	25	232
109S484	120×120mm	25	242
109S485	120×120mm	25	242
109S487	120×120mm	25	242
109S488	120×120mm	25	242
☆109S081	120×120mm	25	232
☆109S082	120×120mm	25	232
☆109S083	120×120mm	25	232
☆109S089	120×120mm	25	232
※109S086	120×120mm	25	232
※109S486	120×120mm	25	242
109S005	120×120mm	38	232
109S005UL	120×120mm	38	232
109S008	120×120mm	38	232
109S008UL	120×120mm	38	232
109S024	120×120mm	38	232
109S024UL	120×120mm	38	232
109S025	120×120mm	38	232
109S025UL	120×120mm	38	232
109S072UL	120×120mm	38	233
109S074UL	120×120mm	38	233
109S075UL	120×120mm	38	233
109S078UL	120×120mm	38	233
109S405UL	120×120mm	38	242
109S408UL	120×120mm	38	242
109S424UL	120×120mm	38	242
109S425UL	120×120mm	38	242
109S472UL	120×120mm	38	243
109S474UL	120×120mm	38	243
109S475UL	120×120mm	38	243
109S478UL	120×120mm	38	243
☆109S013	120×120mm	38	233
☆109S013UL	120×120mm	38	233
☆109S029UL	120×120mm	38	233
☆109S429UL	120×120mm	38	242
※109S006	120×120mm	38	233
※109S006UL	120×120mm	38	233
※109S010	120×120mm	38	233
※109S010UL	120×120mm	38	233
※109S406UL	120×120mm	38	242
109-601	160×160mm	51	234
109-602	160×160mm	51	234
109-603	160×160mm	51	234
109-604	160×160mm	51	234
109-641	160×160mm	51	244
109-642	160×160mm	51	244
109-643	160×160mm	51	244
109-644	160×160mm	51	244
109-311	φ172	51	238
109-312	φ172	51	238
109-313	φ172	51	238
109-314	φ172	51	238
109-371	φ172	51	246
109-372	φ172	51	246
109-373	φ172	51	246
109-374	φ172	51	246
109S301	φ172	51	236
109S302	φ172	51	236
109S303	φ172	51	236
109S304	φ172	51	236

☆ represents half-speed. ※ represents low-speed



**Finger guards**

Model No.	Size	Thick	Page
109-059	40×40mm type	4	250
109-149	52×52mm type	4	250
109-149E	52×52mm type	4	250
109-139E	60×60mm type	4	250
109-139H	60×60mm type	4	250
109-049C	80×80mm type	5	250
109-049E	80×80mm type	5	250
109-049H	80×80mm type	5	250
109-099C	92×92mm type	5	250
109-099E	92×92mm type	5	250
109-099H	92×92mm type	5	250
109-019C	120×120mm type	5	250
109-019H	120×120mm type	5	250
109-019E	120×120mm type	5	250
109-019K	120×120mm type	5	250
109-722	127×127mm type	5	250
109-723	127×127mm type	3.2	250
109-719	140×140mm type	5.5	250
109-719H	140×140mm type	5.5	250
109-619E	160×160mm type	8	250
109-620	160×160mm type	3.6	250
109-319	φ172mm type	9.5	250
109-319E	φ172mm type	9.5	250
109-319H	φ172mm type	9.5	250
109-320	φ172mm type	3.2	250
109-720	φ200mm type	8	250
109-720H	φ200mm type	8	250
109-721	φ200mm type	3.2	250
109-721H	φ200mm type	3.2	250

**Resin finger guards**

Model No.	Size	Thick	Page
109-1003F13	60mm type	9.5	253
109-1003F20	60mm type	9.5	253
109-1003F30	60mm type	9.5	253
109-1003F40	60mm type	9.5	253
109-1002F13	80mm type	10.5	253
109-1002F20	80mm type	10.5	253
109-1002F30	80mm type	10.5	253
109-1002F40	80mm type	10.5	253
109-1001F13	92mm type	10.5	253
109-1001F20	92mm type	10.5	253
109-1001F30	92mm type	10.5	253
109-1001F40	92mm type	10.5	253
109-1000F13	120mm type	10.5	253
109-1000F20	120mm type	10.5	253
109-1000F30	120mm type	10.5	253
109-1000F40	120mm type	10.5	253

**Filter kits • Screen kits**

Model No.	Size	Thick	Page
109-018	131×155.6	8.5	252
109-020	131×155.6	8.5	254

**Resin filter kits**

Model No.	Size	Thick	Page
109-1003F13	60mm type	9.5	253
109-1003F20	60mm type	9.5	253
109-1003F30	60mm type	9.5	253
109-1003F40	60mm type	9.5	253
109-1002F13	80mm type	10.5	253
109-1002F20	80mm type	10.5	253
109-1002F30	80mm type	10.5	253
109-1002F40	80mm type	10.5	253
109-1001F13	92mm type	10.5	253
109-1001F20	92mm type	10.5	253
109-1001F30	92mm type	10.5	253
109-1001F40	92mm type	10.5	253
109-1000F13	120mm type	10.5	253
109-1000F20	120mm type	10.5	253
109-1000F30	120mm type	10.5	253
109-1000F40	120mm type	10.5	253

**Plug cord**

Model No.	Size	Thick	Page
489-008-L10			256
489-008-L21			256
489-008-L35			256
489-016-L10			256
489-016-L21			256
489-006-L10			256
489-006-L21			256
489-007-L10			257
489-007-L21			257
489-047-L10			257
489-047-L21			257
489-084-L10			257
489-084-L21			257
489-086-L10			257
489-086-L21			257

**Thermistor**

Model No.	Size	Thick	Page
169-002			258

## Overseas Sales Network

### JAPAN SANYO DENKI CO., LTD.

Head Office  
1-15-1, Kita-Otsuka, Toshima-ku, Tokyo 170-8451, Japan  
International Sales Dept.  
TEL: +81 3 3917 2223 (North America district)  
TEL: +81 3 3917 5157 (Europe district)  
TEL: +81 3 3917 2814 (Asia district)  
FAX: +81 3 3917 4521  
www.sanyodenki.co.jp

### USA SANYO DENKI AMERICA, INC.

468 Amapola Avenue Torrance, CA 90501 U.S.A.  
TEL: +1 310 783 5400 FAX: +1 310 212 6545  
www.sanyo-denki.com

### USA SANYO DENKI AMERICA, INC.

Silicon Valley Office  
1700 Wyatt Dr. Suite 17 Santa Clara, CA 95054 U.S.A.  
TEL: +1 408 988 1700 FAX: +1 408 982 1700

### USA SANYO DENKI AMERICA, INC.

New England Office  
271 Waverley Oaks Road, Suite 103 Waltham, MA 02452 U.S.A.  
TEL: +1 781 392 2121 FAX: +1 781 392 2132

### USA SANYO DENKI AMERICA, INC.

Midwest Office  
100 Fairway Drive, Suite 126 Vernon Hills, IL 60061 U.S.A.  
TEL: +1 847 362 3723 FAX: +1 847 362 4903

### USA SANYO DENKI AMERICA, INC.

Southern States Office  
1850 North Greenville Avenue, Suite 174 Richardson, Texas 75081, U.S.A.  
TEL: +1 972 479 1313 FAX: +1 972 479 1330

### USA SANYO DENKI AMERICA, INC.

Austin Office  
13284 Pond Springs Road, Austin, Texas 78729, U.S.A.  
TEL: +1 512 335 7100 FAX: +1 512 335 7111

### FRANCE SANYO DENKI EUROPE SA.

P.A. Paris Nord II 48 Allée des Erables-VILLEPINTE BP.57286  
F-95958 ROISSY CDG Cedex France  
TEL: +33 1 48 63 26 61 FAX: +33 1 48 63 24 16  
www.sanyodenkieuropa.fr

### ITALY R.T.A. s.r.l.

Via Enrico Mattei fraz. Divisa 27020 Marcignago (PV) Italy  
TEL: +39 0382 929855 FAX: +39 0382 929150  
www.rta.it

### GERMANY SANYO DENKI GERMANY GmbH

Frankfurter Strasse 63-69 65760 Eschborn Germany  
TEL: +49 6196 76113 0 FAX: +49 6196 76113 99

### GERMANY Telemeter Electronic GmbH

Joseph-Gansler-strasse 10 D-86609 Donauwörth, Germany  
TEL: +49 906 706 93 0 FAX: +49 906 706 93 50  
www.telemeter.de

### GERMANY R.T.A. Deutschland GmbH.

Bublitzter Strasse 34 D-40599 Dusseldorf, Germany  
TEL: +49 211 74966860 FAX: +49 211 74966866  
www.rta-deutschland.de

### BELGIUM SERVOTRONIC

Wasseri jstraat 3, B-2900 SCHOTEN, Belgium  
TEL: +32 3 326 4666 FAX: +32 3 326 1393  
www.servotronic.be

### DENMARK SKAARUP IMCASE A/S

Vasekaer 6-8 DK-2730 Herlev, Denmark  
TEL: +45 4485 0485 FAX: +45 4494 9989  
www.skaarupimcase.dk

### UNITED KINGDOM EAO LTD.

Albert Drive, Burgess Hill, West Sussex RH15 9TN, U.K.  
TEL: +44 01444 23 6000 FAX: +44 01444 23 6641  
www.eao-group.com

### UNITED KINGDOM WYKO INDUSTRIAL SERVICES

Amber Way Halesowen B62 8WG U.K.  
TEL: +44 121 508 6000 FAX: +44 121 508 6255  
www.wyko.co.uk

### FINLAND WEXON OY

Juhanilantie 4 FIN-01740 Vantaa, Finland  
TEL: +358 9 290 440 FAX: +358 9 290 44100  
www.wexon.fi

### ESTONIA DIGIMEN

Akadeemia Tee 33/210 12618 Tallinn, Estonia  
TEL: +372 6726515 FAX: +372 6726591  
www.digimen.ee

### SPAIN DIODE Espana S.A.

Orense 34, 28020 Madrid, Spain  
TEL: +91 456 8100 FAX: +91 555 7628  
www.diode.es

### SPAIN SERVICIO INDUSTRIAL DE ELECTRONICA S.A.

Pol. Ind. Monguit-Centelles S/N 08480 L' ametlla Des Valles-  
Barcelona Spain  
TEL: +34 93 846 4801 FAX: +34 93 849 1394

### SWITZERLAND Telemeter Electronic GmbH

Kirchstraße 28 CH-8574 Lengwil-Oberhofen/TG, Switzerland  
TEL: +41 71 699 20 20 FAX: +41 71 699 20 24  
www.telemeter.ch

### CZECH REPUBLIC ENIKA spol. s.r.o.

Nadorazni 609,509 01 Nova Paka, Czech Republic  
TEL: +420 493 77 33 11 FAX: +420 493 77 33 22  
www.enika.cz

### TURKEY TEKA TEKNİK Cihazlar Sanayi ve Ticaret A.S.

Altan Erbulak Sk No.3 Kat 3 80300 Mecidiyekoy, Istanbul  
Turkey  
TEL: +90 212 274 51 24 FAX: +90 212 272 15 68  
www.takateknik.com.tr

### ISRAEL CONLOG LTD.

7 Leshem St., Petach Tikva, P.O.B 3571 Petach Tikva 49134,  
Israel  
TEL: +972 3 9269565 FAX: +972 3 9233367

### ISRAEL RADION ENGINEERING COMPANY LTD.

11, Haslivil St., P.O.B 7111 Petah-Tikvah, 49250, Israel  
TEL: +972 3 9226688 FAX: +972 3 9226655

### SWEDEN All Motion Technology AB

Tumstocksvagen 11B, S-187 66 Taby, Sweden  
TEL: +46 8 446 37 70 FAX: +46 8 732 68 35

### POLAND SEMICON Sp. z o.o.

Ul. Zwolenska 43, 04-761 Warsaw, Poland  
TEL: +48 22 615 73 71 FAX: +48 22 615 73 75  
www.semicon.com.pl

### HUNGARY Q-TECH Engineering Ltd. & Co.

Batthyany Lajos u. 8. H-1161 Budapest, Hungary  
TEL: +36 1 405 33 38 FAX: +36 1 405 91 34  
www.q-tech.hu

### AUSTRALIA SANTRON (AUST) PTY LTD

17A Leader Street, Somerton Vic Australia, 3062  
TEL: +61 3 9308 8344 FAX: +61 3 9308 8644

### AUSTRALIA BRAEMAC PTY LTD

1/59-61 Burrows Road, Alexandria NSW 2015, Australia  
TEL: +61 2 9550 6600 FAX: +61 2 9550 6377

### AUSTRALIA Avnet (Australia) Pty.Ltd.

2 Giffnock Avenue Macquarie Park NSW 2113 Australia  
TEL: +61 2 9878 1298 FAX: +61 2 9878 1266  
www.avnet.com.au/em/

### INDIA SYSTEM CONTROLS

73-B, Keonics Industrial Estate, Electronics City, Bangalore 560 100, India  
TEL: +91 80 2852 2297 FAX: +91 80 2852 3507  
www.systemcontrols.com

### TAIWAN SANYO DENKI TAIWAN CO., LTD.

Room 1208, 12F, No.96 Chung Shan N. Rd., Sec.2, Taipei 104,  
Taiwan, R.O.C.  
TEL: +886 2 2511 3938 FAX: +886 2 2511 3975

### TAIWAN SUN HOLY TRADING CO., LTD.

3F, No.78 Sec.2 Chang An E. Rd Taipei Taiwan R.O.C  
TEL: +886 2 2516 6060 FAX: +886 2 2508 0323

### TAIWAN YUNG HO CO.LTD.

5th Fl., 36. Kuan Chien Rd., Taipei 100, Taiwan, R.O.C.  
TEL: +886 2 2311 6561 FAX: +886 2 2311 6469

### TAIWAN QuadRep Electronics [T] Ltd.

4F-10, No.79, Hsin Tai Wu Rd., Sec. 1, Hsi-Chih, Taipei,  
Taiwan, R.O.C.  
TEL: +886 2 2698 9933 FAX: +886 2 2698 9911  
www.quadrep.com.tw

### SINGAPORE SANYO DENKI SINGAPORE PTE.LTD.

10 Hoe Chiang Road #14-03A/04 Keppel Towers Singapore 089315  
TEL: +65 6223 1071 FAX: +65 6223 3581

### SINGAPORE SAN-ACE ELECTRONICS (S) PTE LTD.

No.10 Jalan Besar No.12-12 Sim Lim Tower, Singapore 208787  
TEL: +65 6292 6565 FAX: +65 6291 4563

### SINGAPORE

#### NEMATRON CONTROL SYSTEM (ASIA) PTE LTD

1001 Jalan Bukit Merah #05-08, Singapore 159455  
TEL: +65 6272 5268 FAX: +65 6272 8498

#### SINGAPORE QuadRep Marketing (S) Pte Ltd

53 Ubi Avenue 1, #03-30 Paya Ubi Industrial Park, Singapore 408934  
TEL: +65 6346 1933 FAX: +65 6346 1911  
www.quadrep.com.sg

### INDONESIA PT. JASINTO PRIMA SAKTI

Jin. K.H. Zainul Arifin Blok B2/No.24 Komplek Ketapang Indah,  
Jakarta 11140 Indonesia  
TEL: +62 21 634 3044 FAX: +62 21 633 8108

### HONG KONG SANYO DENKI (H.K.) CO., LIMITED

Rm2305,23/F, South Tower, Concordia Plaza, 1 Science  
Museum Rd., Tsimshatsui East, Kowloon, Hong Kong  
TEL: +852 2312 6250 FAX: +852 2312 6220

### HONG KONG MELCO TRADING CO., LTD

1/F, Cheong Fat Factory Bldg., No.269-271 Un Chau Street, Kowloon,  
Hong Kong  
TEL: +852 2361 0102 FAX: +852 2387 4057  
www.melco.com.hk

### HONG KONG SMC Pneumatics (Hong Kong) Ltd.

29/F., Clifford Centre, 778-784 Cheung Sha Wan Rd., Kowloon,  
Hong Kong.  
TEL: +852 2744 0121 FAX: +852 2785 1314

### HONG KONG FLEXIBLE AUTOMATION SYSTEM LTD

Block B4, 1/FL, Tonic Industrial Centre, 19 Lam Hing Street,  
Kowloon Bay, Hong Kong.  
TEL: +852 2796 9866 FAX: +852 2796 9978

### KOREA SANYO DENKI KOREA CO., LTD.

9F 5-2, Sunwha-dong Jung-gu Seoul, 100-130, Korea  
TEL: +82 2 773 5623 FAX: +82 2 773 5629

### KOREA HY TECH CO., LTD. (former HAN YANG CORP.)

Renaissance Tower B/D 11F #1110, 456, Gongdeok-dong,  
Mapo-gu, Seoul, 121-020, Korea  
TEL: +82 2 713 4343 FAX: +82 2 713 4332  
www.hytech.co.kr

### THAILAND COSMOS POLYTECH LTD.

19/300 Moobanchaikul Moo 10, Rama 2 Rd, Kwang Bangmod,  
Khet Jomthong, Bangkok 10150, Thailand  
TEL: +66 2 898 5313 FAX: +66 2 898 5314

### CHINA SANYO DENKI SHANGHAI CO., LTD.

Room 2116, Bldg B, FAR EAST INTERNATIONAL  
PLAZA, No.317 XianXia Rd., Shanghai 200051 China  
TEL: +86 21 6235 1107 FAX: +86 21 6278 8289

### CHINA

#### BEIJING YANGHAI AUTOMATION TECHNOLOGY CO., LTD.

Room 1008, No.7, Huaqing Business Building, Huaqing  
Garden, Wudaokou, Haidian District, Beijing P.R.C. Postal  
Code: 100083  
TEL: +86 10 8286 7980 FAX: +86 10 8286 7987

### CHINA

#### SHANGHAI DEZO INDUSTRIAL EQUIPMENT TECHNOLOGY CO., LTD.

6F(E), Zhangjiang Hi-Tech Park, No.470 Chunxiao  
Rd.(E)Shanghai, 201203 China  
TEL: +86 21 5080 2960 FAX: +86 21 5080 2962

### CHINA MELCO INTERNATIONAL TRADING(SHANGHAI) CO., LTD.

Flat B, 9/F, DaTong Commercial Tower, No.369 FuXing Road  
Central, Shanghai 200025 China  
TEL: +86 21 6320 1250 FAX: +86 21 6320 0490  
www.melco.com.cn

### CHINA

#### KOYO ELECTRONICS (WUXI) CO., LTD.

No.118 Lixi Road, Wuxi, Jiangsu, 214072 China  
TEL: +86 510 5167 888 FAX: +86 510 5161 393

### CHINA

#### SHEN SING COMPANY LIMITED (Wu Xi Office)

18th floor, Unit H, Wah Kwong Building, 333 Zhong Shan  
Road, Wu Xi, Jian Su, China, 214001  
TEL: +86 510 2738 091 FAX: +86 510 2763 243  
www.cehgp.com

### CHINA

#### SHEN SING COMPANY LIMITED (Tianjin Office)

Weidiroad Hexidc, Tianjin, China, Tianjin Winsun Plaza  
B-24F, China, 300201  
TEL: +86 22 8823 8577 FAX: +86 22 8823 8578  
www.cehgp.com

### CHINA

#### SHEN SING COMPANY LIMITED (Shenzhen office)

Unit1906, Dongfeng Building, 2010 Shen Nan Zhong Road,  
Futian District, Shenzhen City, P.R. China  
TEL: +86 755 8378 6101 FAX: +86 755 8378 6095

### CHINA

#### QuadRep Electronics [C] Ltd. (Shanghai)

Room 1102, Block B, Lane 547, West Tian Mu Rd, Shanghai,  
China, 200070  
TEL: +86 21 6317 5445 FAX: +86 21 6317 6042  
www.quadrep.com.tw

### CHINA

#### QuadRep Electronics [C] Ltd. (Beijing)

Room 502, Build 20, No 8, Da Hui Si Road, Haidian District,  
Beijing,  
P.R.C. Postal Code:10081  
TEL: +86 10 6211 5141 FAX: +86 10 6211 5141  
www.quadrep.com.tw

### CHINA

#### QuadRep Electronics [C] Ltd. (Shenzhen)

Room 13A, Bldg, Yonghui, Guoqi Building, Shang Bu South  
Road, Shenzhen, China, 518031  
TEL: +86 755 2588 0414 FAX: +86 755 2588 0415  
www.quadrep.com.tw



## Note

---

## Note

---

## Note

---

## User Registration Information

By becoming a Registered User, you will receive up to date brochure for our new products release.

### **[How to register]**

Just e-mail us the following required information to **sales@sanyodenki.co.jp** to become registered.

#### **■Required Information**

- ① Your Full Name (First then Last)
- ② Full Company name
- ③ Department / Division
- ④ Full Address
- ⑤ Phone number / Fax number
- ⑥ Valid E-mail address

SANYO DENKI CO., LTD.