

San Ace C175

Centrifugal Fan

Features

Large air flow and high static pressure

- Maximum air flow : 14.0 m³/min
- Maximum static pressure : 885 Pa

Energy-saving design

- Power consumption: 93.6 W

Low noise

- Sound Pressure Level: 73dB(A)



Centrifugal Fan 175mm

175mm × 69mm

Specifications Note 3

Model No.	Rated Voltage [V]	Operating Voltage Range [V]	PWM Duty Cycle [%] <small>Note 1,2)</small>	Rated Current [A]	Rated Input [W]	Rated Speed [min ⁻¹]	Air Flow		Static Pressure		SPL [dB(A)]	Operating Temperature [°C]	Life Expectancy [h]
							[m ³ /min]	[CFM]	[Pa]	[inchH ₂ O]			
9TG48P0G01	48	36 to 55.2	100	1.95	93.6	4,700	14.0	494.7	885	3.55	73	- 10 to + 70	40,000

Note 1 : PWM Frequency : 25kHz

Note 2 : Fan does not rotate when PWB duty cycle is 0%.

Note 3 : When inlet nozzle[Option (Model : 109-1073)] is mounted.

Note 4 : Max input is 130 W at rated voltage.

Common Specifications

Material	Frame: Aluminum, Impeller: Plastics (Flammability: UL94V-1Min.)
Life Expectancy	Varies for each model (L10: Survival rate: 90% at 60 °C, rated voltage, and continuously run in a free air state)
Motor Protection System	Current blocking function and Reverse polarity protection
Dielectric Strength	50/60 Hz, 500VAC, 1 minute (between lead conductor and frame)
Sound Pressure Level (SPL)	Expressed as the value at 1m from air inlet side
Operating Temperature	Varies for each model (Non-condensing)
Storage Temperature	- 30 to + 70 (Non-Condensing)
Lead Wire	+ red -black Sensor: yellow Control: brown
Mass	Approx. 750g

175mm

SanAce C175

Air Flow and Static Pressure Characteristics

- PWM Duty Cycle

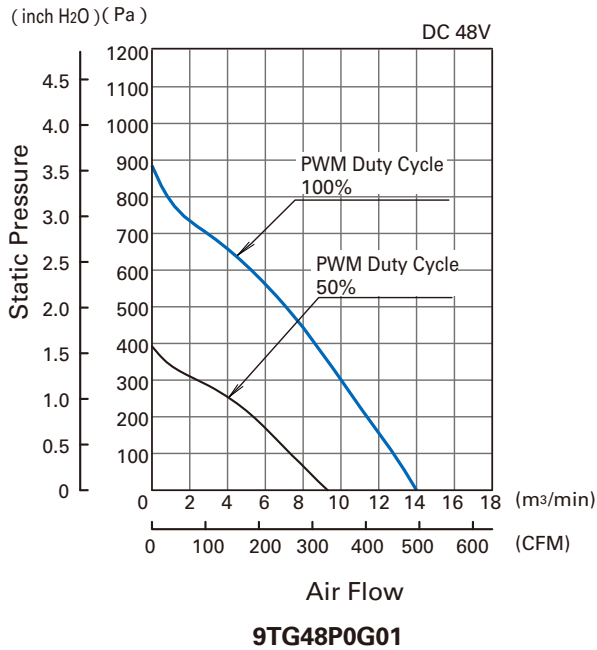

- Operating Voltage Range

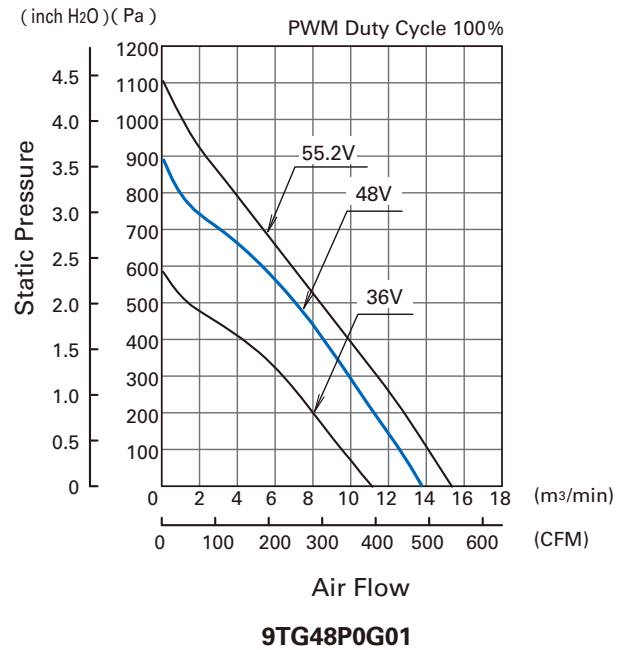

PWM Duty - Speed Characteristics Example

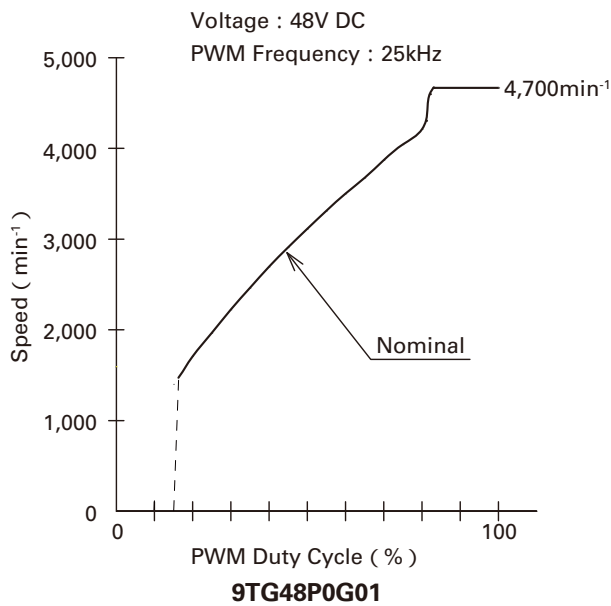

PWM Input Signal Example

Input Signal Wave Form

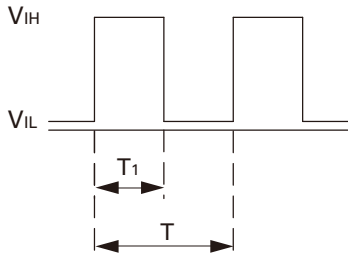

$V_{IH}=4.75V$ to $5.25V$

$V_{IL}=0V$ to $0.4V$

$$\text{PWM Duty Cycle (\%)} = \frac{T_1}{T} \times 100$$

$$\text{PWM Frequency 25 (kHz)} = \frac{1}{T}$$

Source Current : 2mA Max. at control voltage 0V

Sink Current : 1mA Max. at control voltage 5.25V

Control Terminal Voltage : 5.25V Max. (Open Circuit)

When the control lead wire is no connecting, the speed is the same speed as at 100% of PWM cycle.

This fan speed should be controlled by PWM input signal of either TTL input or open collector, drain input.

Connection Schematic

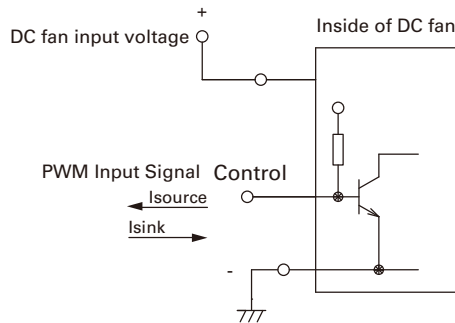

Specifications for Pulse Sensors

Output circuit : Open collector

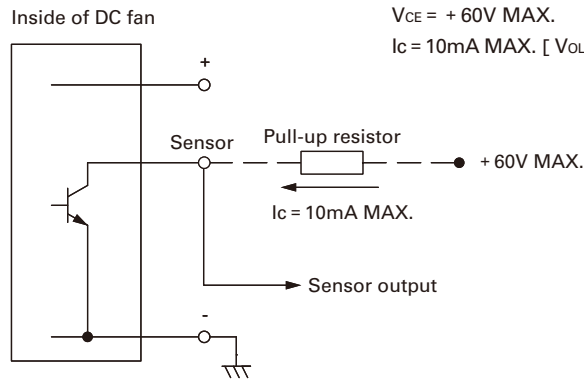

$V_{CE} = +60V$ MAX.

$I_c = 10mA$ MAX. [$V_{OL} = V_{CE(SAT)} = 0.4V$ MAX.]

Output waveform (Need pull-up resistor)

In case of steady running

(One revolution)

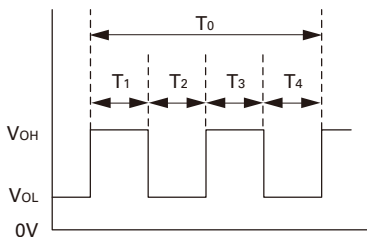

$$T_{1-4} = (1/4)T_0$$

$$T_{1-4} = (1/4)T_0 = 60/4N \text{ (sec)}$$

$$N = \text{Fan speed (min}^{-1}\text{)}$$

Dimensions (unit : mm)

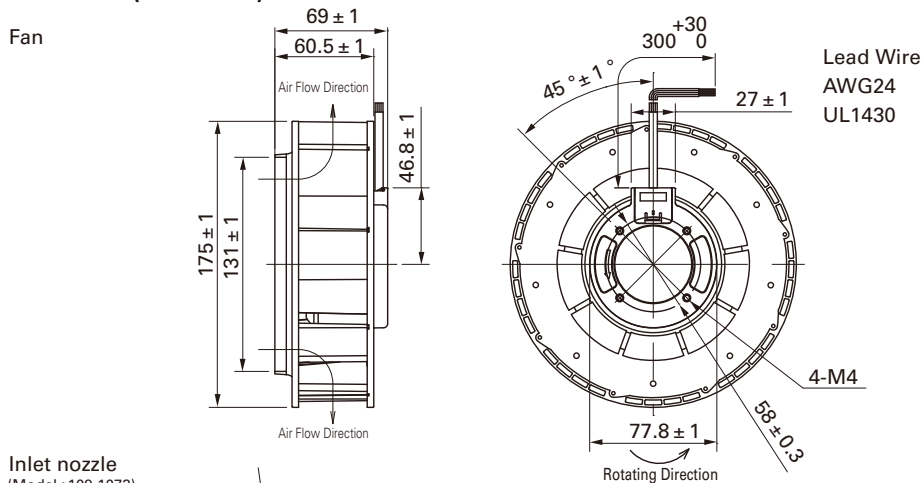

Inlet nozzle
(Model : 109-1073)

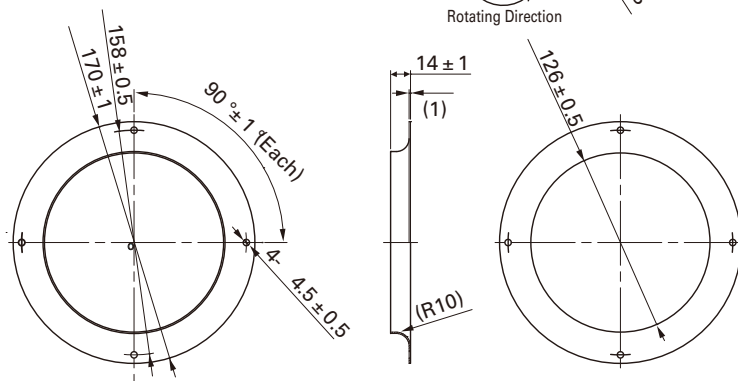

Inlet nozzle: Nozzle mounted in fan inlet side to adjust the flow of introduced air

Reference dimension of mounting holes and vent opening (unit : mm)

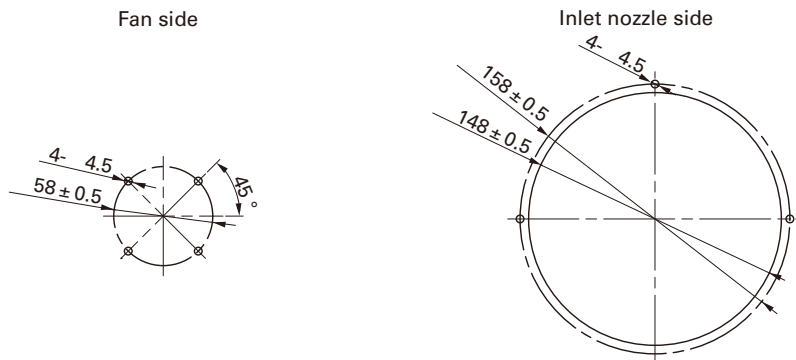

Referance diagram for mounting

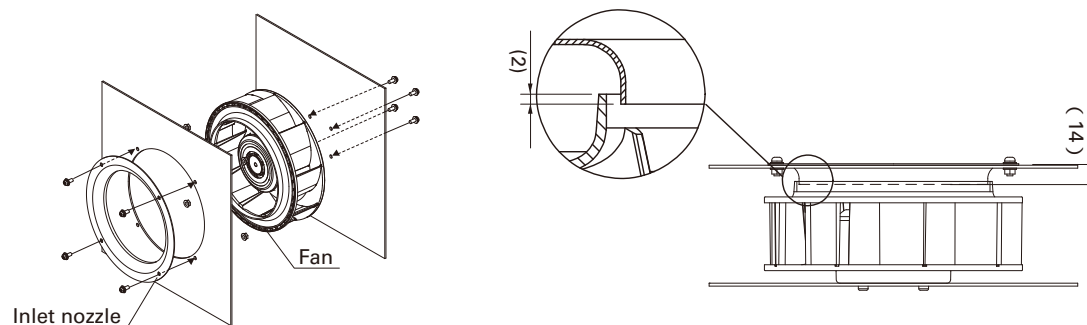

Screw length should be 4 mm or more but not exceeding 6 mm from fan edge face.
To prevent screw from loosing, use plain washer and spring washer.

Notice

The products shown in the catalog are subject to Japanese Export Control Law. Diversion contrary to the law of exporting country is prohibited.
To protect against electrolytic corrosion that may occur in locations with strong electromagnetic noise, we provide fans that are unaffected by electrolytic corrosion.

SANYO DENKI CO., LTD. 1-15-1, Kita-otsuka, Toshima-ku, Tokyo 170-8451, Japan. PHONE :+ 81 3 3917 5151 Home Page: <http://www.sanyodenki.co.jp>