

ALL RIGHTS RESERVED. NO PORTION OF THIS PUBLICATION, WHETHER IN WHOLE OR IN PART CAN BE REPRODUCED WITHOUT THE EXPRESS WRITTEN CONSENT OF SPC TECHNOLOGY.

SPC-F006.DWG

REVISIONS		DOC. NO. SPC-F006	Effective 7/8/02		DCP No. 1308	
DCP #	REV	DESCRIPTION	DRAWN	DATE	CHECKD	DATE
1888	A	RELEASED	DCM	5/3/08	JN	08/17/08
						08/17/08

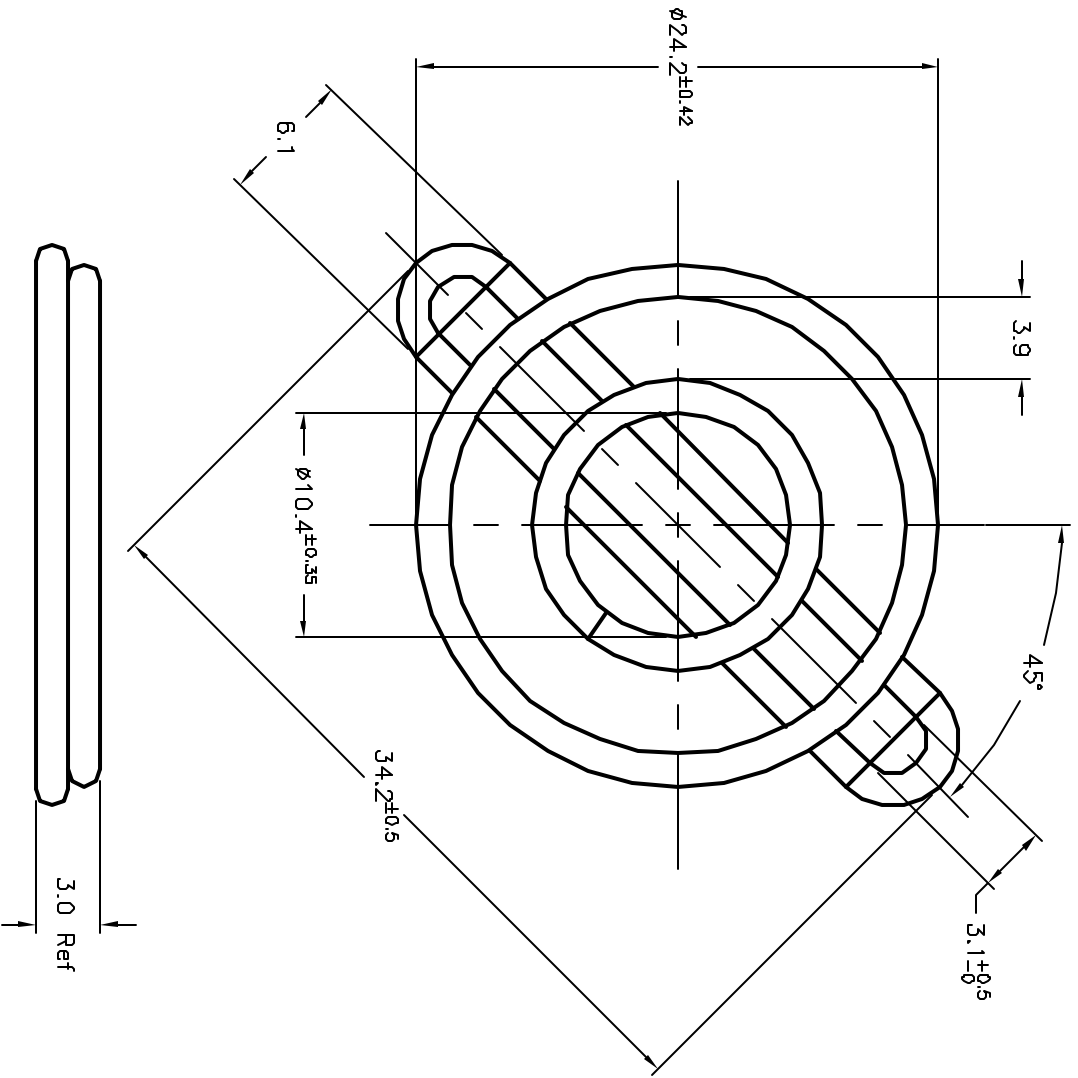

- NOTES:
- Material: SAE 1008 (or Equivalent) Bright Basic Wire
  - Finish: Bright Nickel Chrome Plating (Trivalent Chrome)
  - 0.30±0.05 Depth of Serrations on wire.
  - Weld joints to withstand 70 Lbs pull force.
  - Ring:  $\phi 1.5$ ; Rib:  $\phi 1.5$

DISCLAIMER: ALL STATEMENTS AND TECHNICAL INFORMATION CONTAINED HEREIN ARE BASED UPON INFORMATION AND/OR TESTS WE BELIEVE TO BE ACCURATE AND RELIABLE. SINCE CONDITIONS OF USE ARE BEYOND OUR CONTROL, THE USER SHALL DETERMINE THE SUITABILITY OF THE PRODUCT FOR THE INTENDED USE AND ASSUME ALL RISK AND LIABILITY WHATSOEVER IN CONNECTION THEREWITH.

TOLERANCES: UNLESS OTHERWISE SPECIFIED, DIMENSIONS ARE FOR REFERENCE PURPOSES ONLY.

DRAWN BY:	DATE:
Dan McVicker	5/3/06
CHECKED BY:	DATE:
Jason Nash	09/17/08
APPROVED BY:	DATE:
Jason Nash	09/17/08

DRAWING TITLE:		DRAWING NO.		ELECTRONIC FILE	
25mm Wire Form Fan Guard		SPC19736		76K0451.dwg	
SCALE:	NTS	U.O.M.:	Millimeters	SHEET:	1 OF 1