

ALL RIGHTS RESERVED. NO PORTION OF THIS PUBLICATION, WHETHER IN WHOLE OR IN PART CAN BE REPRODUCED WITHOUT THE EXPRESS WRITTEN CONSENT OF SPC TECHNOLOGY.

REVISIONS			DOC. NO. SPC-F005 • Effective: 12/21/98 • DCP No: 680					
DCP #	REV	DESCRIPTION	DRAWN	DATE	CHECKD	DATE	APPRVD	DATE
2033	A	RELEASED	JN	03/31/09	JWM	03/31/09	JWM	03/31/09

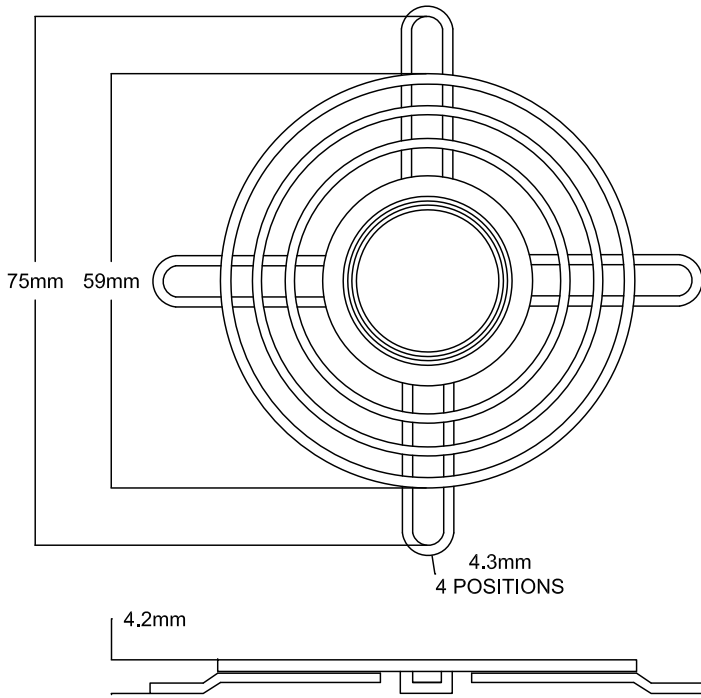

NOTES

1. Material: C1008 Steel
2. Plating: Bright Nickel Chrome
3. Ring Diameter: 1.2mm
4. Rib Diameter: 1.5mm

DISCLAIMER:
ALL STATEMENTS AND TECHNICAL INFORMATION CONTAINED HEREIN ARE BASED UPON INFORMATION AND/OR TESTS WE BELIEVE TO BE ACCURATE AND RELIABLE. SINCE CONDITIONS OF USE ARE BEYOND OUR CONTROL, THE USER SHALL DETERMINE THE SUITABILITY OF THE PRODUCT FOR THE INTENDED USE AND ASSUME ALL RISK AND LIABILITY WHATSOEVER IN CONNECTION THEREWITH.

Tolerance:
UNLESS OTHERWISE SPECIFIED, DIMENSIONS ARE FOR REFERENCE PURPOSES ONLY.

DRAWN BY:	DATE:
Jason Nash	03/31/09
CHECKED BY:	DATE:
Jeff McVicker	03/31/09
APPROVED BY:	DATE:
Jeff McVicker	03/31/09

Multicomp[®]

DRAWING TITLE:			
Finger Guard			
SIZE	DWG. NO.	ELECTRONIC FILE	REV
A	MC34209	32R8491.dwg	A
SCALE:	U.O.M.:	SHEET:	
NTS	Millimeters	1 OF 1	

SPC-F005.DWG