

Ceramic Resonators (CERALOCK®)



Cat.No.P16E-18

muRata *Innovator
in Electronics*
Murata
Manufacturing Co., Ltd.

for EU RoHS Compliant

- All the products in this catalog comply with EU RoHS.
- EU RoHS is "the European Directive 2002/95/EC on the Restriction of the Use of Certain Hazardous Substances in Electrical and Electronic Equipment".
- For more details, please refer to our website 'Murata's Approach for EU RoHS' (<http://www.murata.com/info/rohs.html>).

CONTENTS

CERALOCK® and "CERALOCK" in this catalog are the trademarks of Murata Manufacturing Co., Ltd.

		2	1
Selection Guide	_____	2	2
Part Numbering	_____	3	
1 MHz Chip Type -Tight Frequency Tolerance for Automotive-	_____	4	
● Application Circuits Utilization	_____	6	3
2 MHz Chip Type -Standard Frequency Tolerance for Automotive-	_____	7	
● Application Circuits Utilization	_____	11	
MHz Chip Type Notice (Soldering and Mounting) for Automotive	_____	12	4
MHz Chip Type Notice for Automotive	_____	13	
MHz Chip Type Packaging for Automotive	_____	14	
3 MHz Chip Type -Tight Frequency Tolerance for General Usage-	_____	16	
● Application Circuits Utilization	_____	20	5
4 MHz Chip Type -Standard Frequency Tolerance for General Usage-	_____	21	
● Application Circuits Utilization	_____	26	6
5 MHz Lead Type -Standard Frequency Tolerance for General Usage-	_____	28	
6 kHz Chip Type -Standard Frequency Tolerance for General Usage-	_____	30	
7 kHz Lead Type -Standard Frequency Tolerance for General Usage-	_____	32	
MHz Chip Type Notice (Soldering and Mounting) for General Usage	_____	34	7
MHz Chip Type Notice for General Usage	_____	38	
MHz Lead Type Notice for General Usage	_____	39	
kHz Type Notice for General Usage	_____	40	
MHz Chip Type Packaging for General Usage	_____	43	
MHz Lead Type Packaging for General Usage	_____	46	
kHz Type Packaging for General Usage	_____	49	

Selection Guide

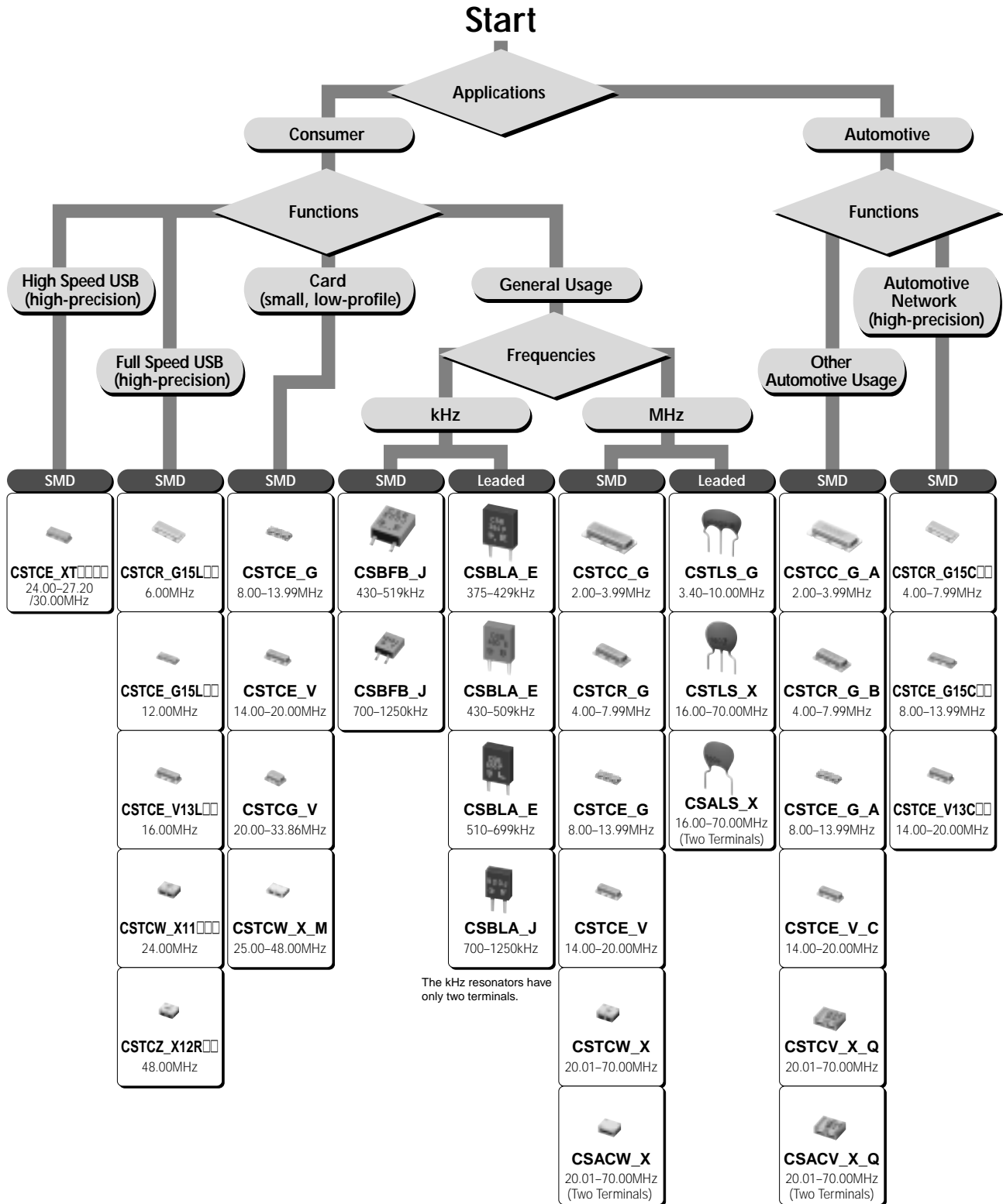

□: Alphanumeric express individual specification

Notice) "CERALOCK® for general usage" and "CERALOCK® for automotive" is different in the specification of Operating Temperature Range, Environmental Characteristics, Physical Characteristics and so on. Please choose either "for general usage" or "for automotive" according to the required specification.

● Part Numbering

CERALOCK® (MHz)

(Part Number)

CS	T	CE	16M0	V	5	3	***	-R0
①	②	③	④	⑤	⑥	⑦	⑧	⑨

① Product ID

Product ID	
CS	Ceramic Resonators

② Frequency/Capacitance

Code	Frequency/Capacitance
A	MHz No capacitance built-in
T	MHz Built-in Capacitance

③ Structure/Size

Code	Structure/Size
LS	Round Lead Type
CC	Cap Chip Type
CR/CE/CG	Small-cap Chip Type
CV	Monolithic Chip Type
CW/CZ	Small Monolithic Chip Type

④ Nominal Center Frequency

Expressed by four-digit alphanumerics. The unit is in hertz (Hz).
 Decimal point is expressed by capital letter "M".

⑤ Design

Code	Design
G□□	Thickness Shear mode
T/V□□	Thickness Expander mode
X□□	Thickness Expander mode (3rd overtone)

□□ indicates initial frequency tolerance and load capacity.

⑥ Initial Frequency Tolerance

Code	Design
5	±0.5%
3	±0.3%
2	±0.2%
1	±0.1%
H	±0.07%
K	-0.025/0.02%

⑦ Load Capacity

Code	Design
1	3/5/6pF
2	10pF
3	15pF
4	22pF
5	30/33/39pF
6	47pF

⑧ Individual Specification

Code	Individual Specification
***	Three-digit alphanumerics express "Individual Specification".

With standard products, "⑧ Individual Specification" is omitted, and "⑨ Packaging" is carried up.

⑨ Packaging

Code	Packaging
-B0	Bulk
-A0	Radial Taping H ₀ =18mm
-R0	Plastic Taping ø=180mm
-R1	Plastic Taping ø=330mm

Radial taping is applied to lead type and plastic taping to chip type.

CERALOCK® (kHz)

(Part Number)

CS	B	FB	500K	J58	***	-R1
①	②	③	④	⑤	⑥	⑦

① Product ID

Product ID	
CS	Ceramic Resonators

② Frequency/Capacitance

Code	Frequency/Capacitance
B	kHz No capacitance built-in

③ Structure/Size

Code	Structure/Size
LA	Two-Terminal Lead Type
FB	SMD Type

④ Nominal Center Frequency

Expressed by four-digit alphanumerics. The unit is in hertz (Hz).
 Capital letter "K" following three figures expresses the unit of "kHz". In case of 1.0MHz (1000kHz) or above, expressed by three figures and capital letter "M" for decimal point.

⑤ Design

Code	Design
E□□	Area Expansion mode
J□□	Area Expansion mode (Closed Type)

□□ indicates initial frequency tolerance and load capacitance.

⑥ Individual Specification

Code	Individual Specification
***	Three-digit alphanumerics express "Individual Specification".

With standard products, "⑥ Individual Specification" is omitted, and "⑦ Packaging" is carried up.

⑦ Packaging

Code	Packaging
-B0	Bulk
-R1	Plastic Taping ø=330mm

Ceramic Resonators (CERALOCK®)



MHz Chip Type -Tight Frequency Tolerance for Automotive-

Chip type "CERALOCK" with built-in load capacitors in an extremely small package provides high accuracy. MURATA's frequency adjustment and package technology expertise has enabled the development of the chip "CERALOCK" with built-in load capacitors. Chip "CERALOCK" for automotive has achieved importance in the worldwide automotive market. This diverse series owes its development to MURATA's original mass production techniques and high reliability.

■ Features

1. The series are high accuracy resonators whose total tolerance is available for less than $\pm 3,000\text{ppm}$.
2. The series has high reliability and is available for wide temperature range.
3. Oscillation circuits do not require external load capacitors.
4. The series is available for a wide temperature range.
5. The resonators are extremely small and have a low profile.
6. No adjustment is necessary for oscillation circuits.

■ Applications

1. Cluster panel and Control panel
2. Safety control
(Anti-lock Brake System, Electronic Stability Control, Airbag, etc.)
3. Engine ECU, Electronic Power Steering, Immobilizer, etc.
4. Car Air-conditioner, Power window, Remote Keyless Entry system, etc.
5. Intelligent Transportation System
(Lane Keeping System, Millimeter wave radar, etc.)
6. Battery control for hybrid car



CSTCR_G15C
4.00-7.99MHz

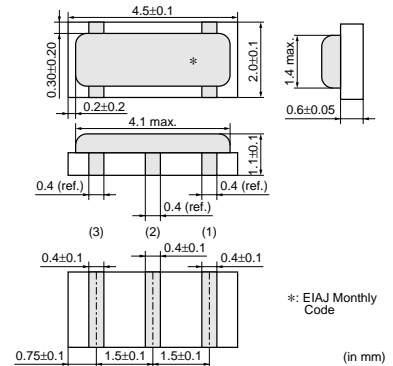

CSTCE_G15C
8.00-13.99MHz

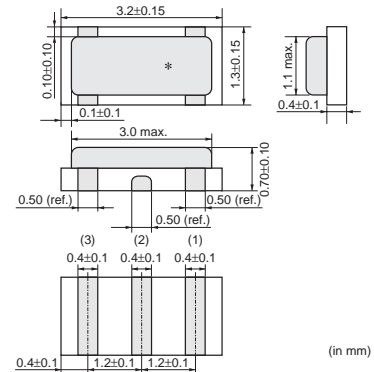

CSTCE_V13C
14.00-20.00MHz

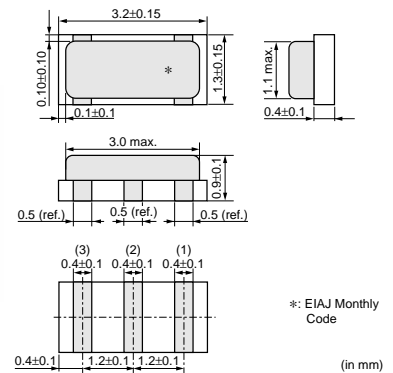

Part Number	Oscillating Frequency (MHz)	Initial Tolerance	Temp. Stability (%)	Temperature Range (°C)
CSTCR_G15C	4.00 to 7.99	$\pm 0.1\%$	± 0.13	-40 to 125
CSTCE_G15C	8.00 to 13.99	$\pm 0.1\%$	± 0.13	-40 to 125
CSTCE_V13C	14.00 to 20.00	$\pm 0.1\%$	± 0.13	-40 to 125

Irregular or stop oscillation may occur under unmatched circuit conditions. Please check the actual conditions prior to use.

■ Oscillation Frequency Measuring Circuit

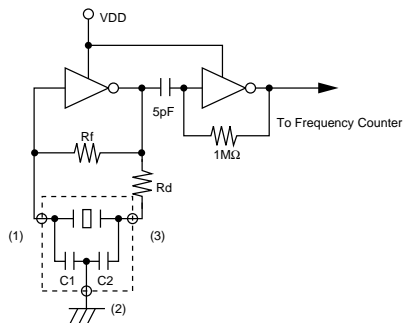

■ Standard Land Pattern Dimensions

CSTCR_G15C

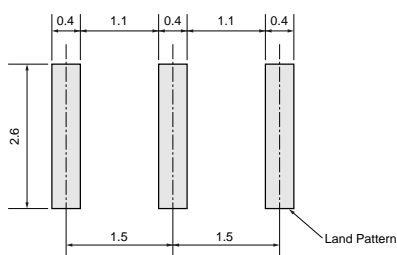

(in mm)

CSTCE_G15C

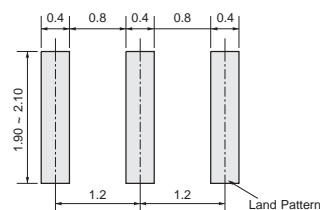

(in mm)

CSTCE_V13C

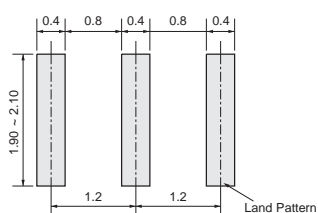

(in mm)

■ Oscillation Frequency Temperature Stability

CSTCR_G15C

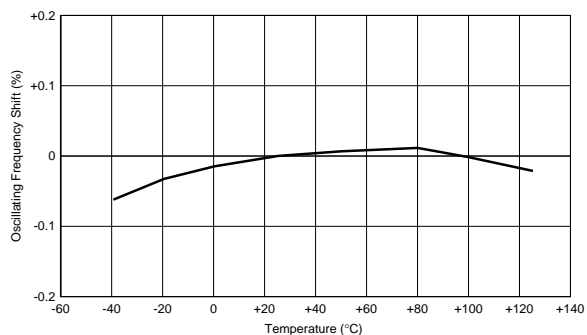

CSTCE_G15C

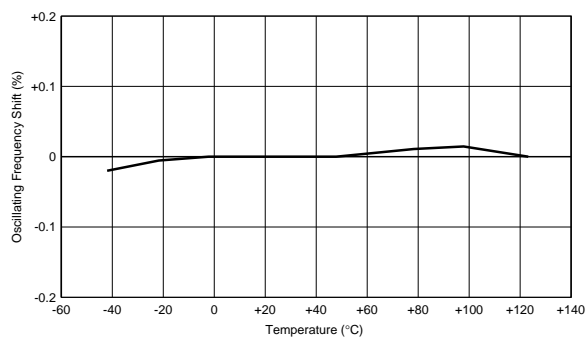

CSTCE_V13C

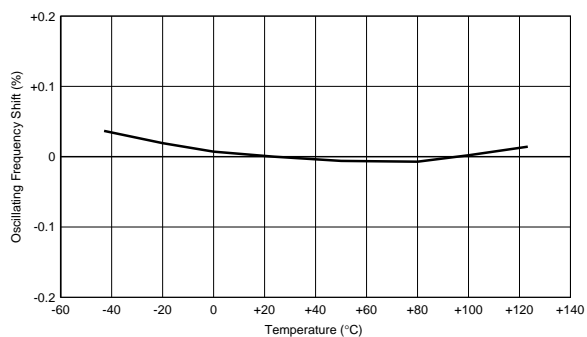

Application Circuits Utilization

■ TMP92CD54IF (Toshiba)

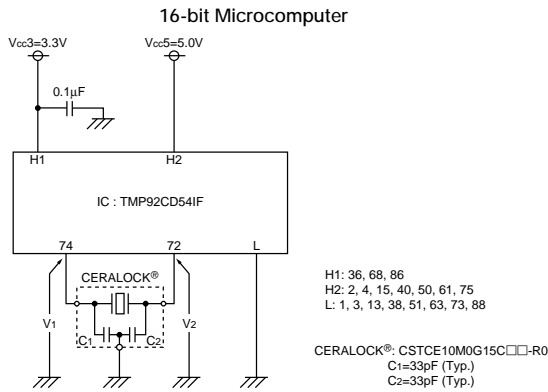

■ MB90F387 (Fujitsu)

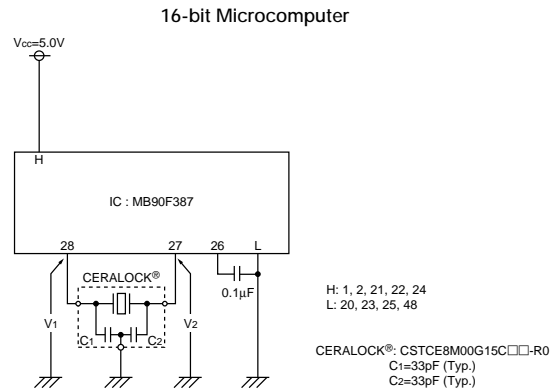

■ MC68HC908AZ60AVFU (Freescale)

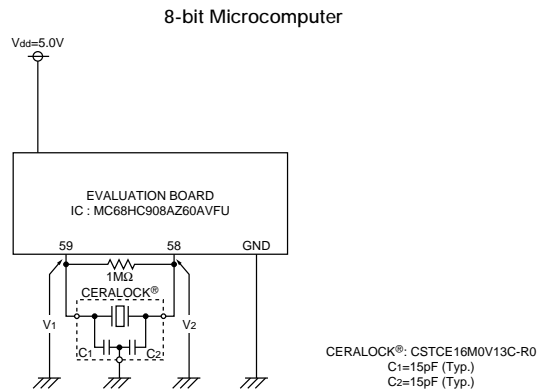

■ ST72F561 (HS) (ST Microelectronics)

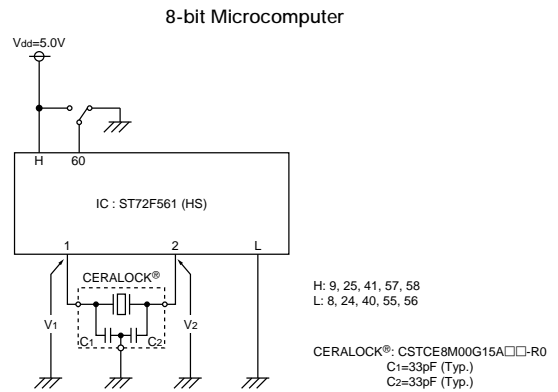

■ uPD70F3283YGC (NEC Electronics)

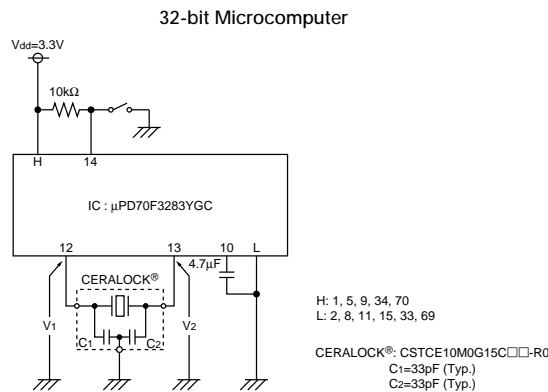

■ M30842MCT-XXXGP (Renesas)

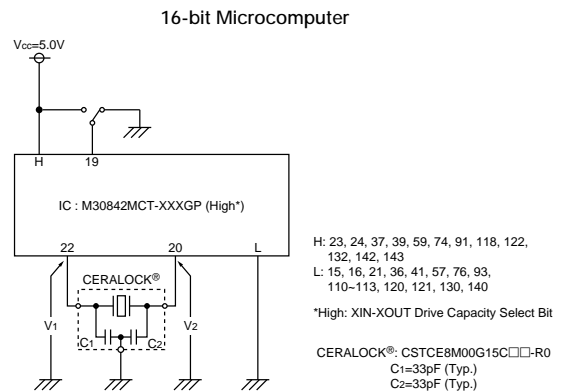

Ceramic Resonators (CERALOCK®)



MHz Chip Type -Standard Frequency Tolerance for Automotive-

Chip type "CERALOCK" with built-in load capacitors in an extremely small package provides high accuracy. MURATA's frequency adjustment and package technology expertise has enabled the development of the chip "CERALOCK" with built-in load capacitors. Chip "CERALOCK" for automotive has achieved importance in the worldwide automotive market. This diverse series owes its development to MURATA's original mass production techniques and high reliability.

■ Features

1. The series has high reliability and is available for wide temperature range.
2. Oscillation circuits do not require external load capacitors.
3. The series is available in a wide frequency range.
4. The resonators are extremely small and have a low profile.
5. No adjustment is necessary for oscillation circuits.

■ Applications

1. Cluster panel and Control panel
2. Safety control
(Anti-lock Brake System, Electronic Stability Control, Airbag, etc.)
3. Engine ECU, Electronic Power Steering, Immobilizer, etc.
4. Car Air-conditioner, Power Window, Remote Keyless Entry system, etc.
5. Electronic Toll Collection system, Car Navigation, etc.

2



CSTCC_G_A
2.00-3.99MHz

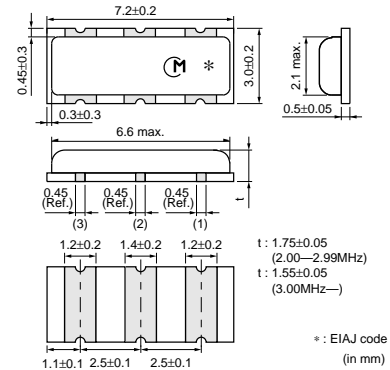

CSTCR_G_B
4.00-7.99MHz

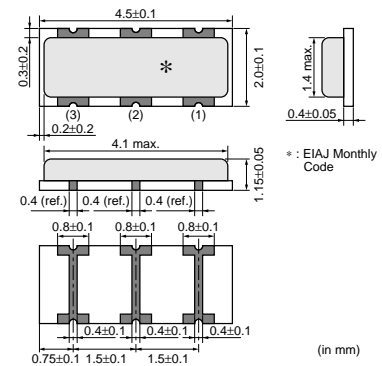

CSTCE_G_A
8.00-13.99MHz

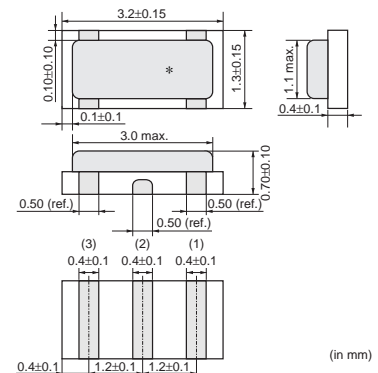

CSTCE_V_C
14.00-20.00MHz

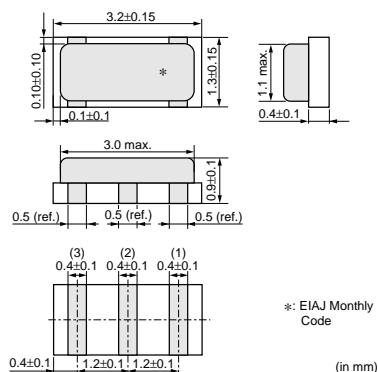

CSACV_X_Q
20.01-70.00MHz

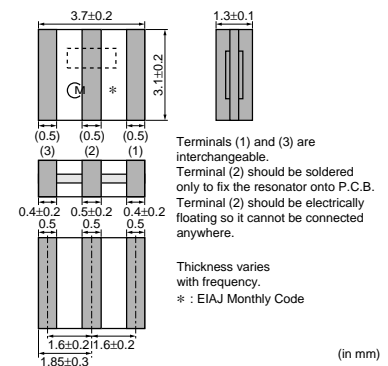

Continued on the following page.

Continued from the preceding page.



CSTCV_X_Q
20.01-70.00MHz

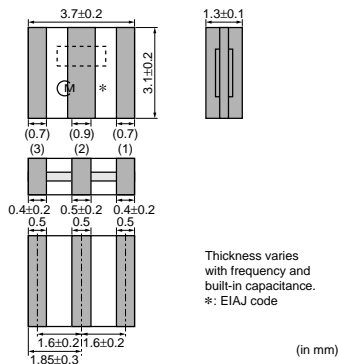

2

Part Number	Oscillating Frequency (MHz)	Initial Tolerance	Temp. Stability (%)	Temperature Range (°C)
CSTCC_G_A	2.00 to 3.99	±0.5%	±0.4 [-0.6% to +0.3%:Built-in Capacitance 47pF type within Freq.2.00 to 3.49MHz]	-40 to 125
CSTCR_G_B	4.00 to 7.99	±0.5%	±0.15	-40 to 125
CSTCE_G_A	8.00 to 13.99	±0.5%	±0.2	-40 to 125
CSTCE_V_C	14.00 to 20.00	±0.5%	±0.15	-40 to 125
CSACV_X_Q	20.01 to 70.00	±0.5%	±0.3	-40 to 125
CSTCV_X_Q	20.01 to 70.00	±0.5%	±0.3	-40 to 125

Irregular or stop oscillation may occur under unmatched circuit conditions. Please check the actual conditions prior to use.

■ Oscillation Frequency Measuring Circuit

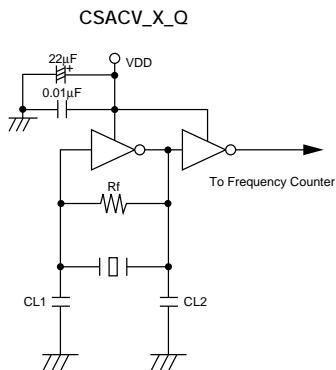
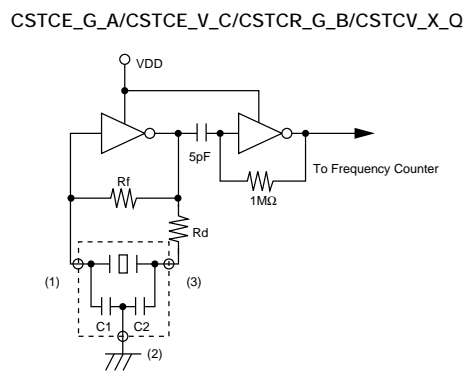
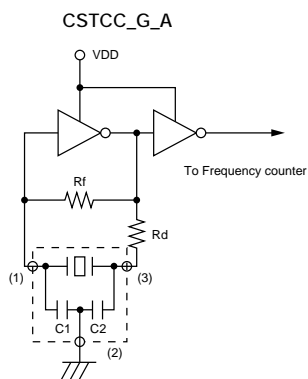

Standard Land Pattern Dimensions

CSTCC_G_A

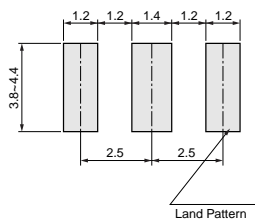

(in mm)

CSTCR_G_B

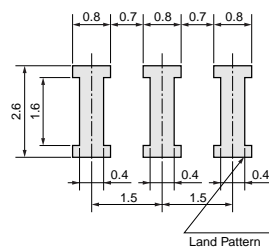

(in mm)

2

CSTCE_G_A

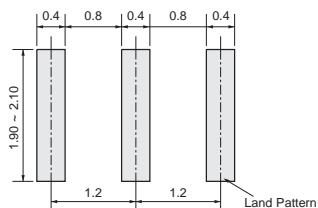

(in mm)

CSTCE_V_C

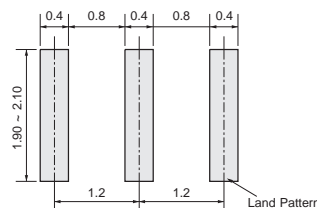

(in mm)

CSTCV_X_Q

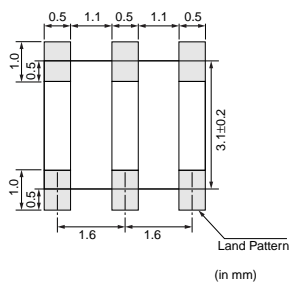

(in mm)

CSACV_X_Q

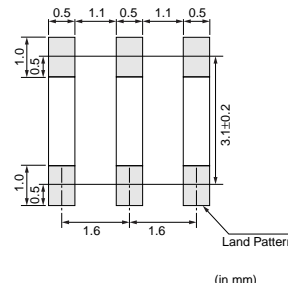

(in mm)

■ Oscillation Frequency Temperature Stability

CSTCC_G_A

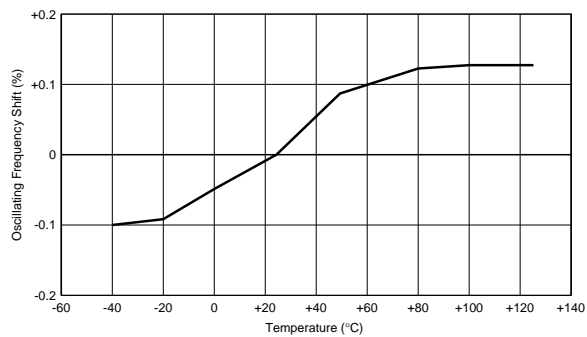

CSTCR_G_B

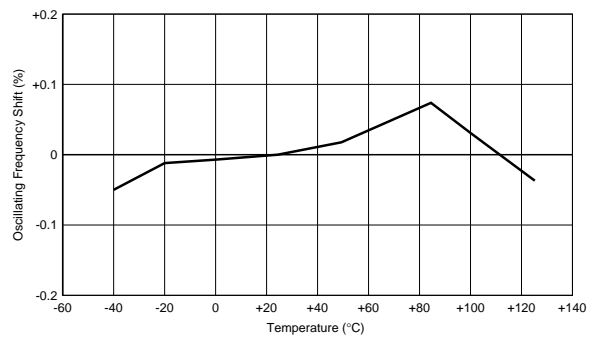

CSTCE_G_A

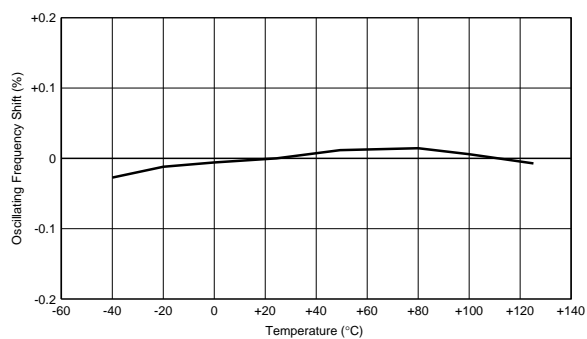

CSTCE_V_C

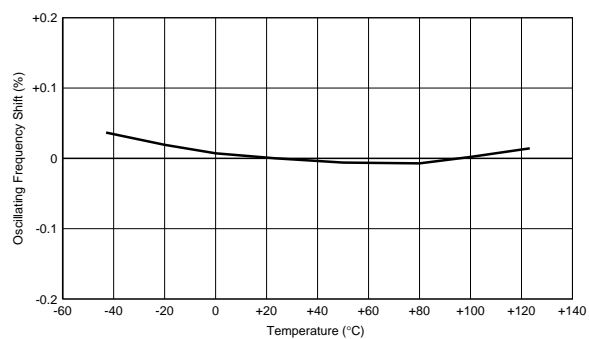

CSTCV_X_Q

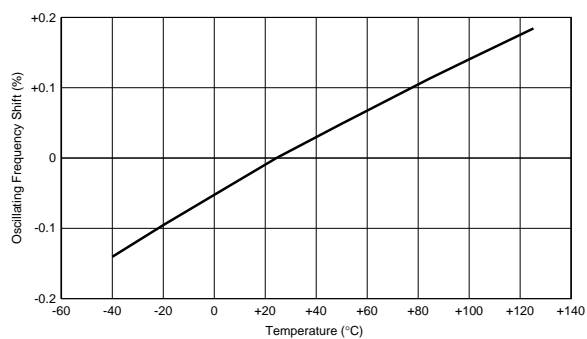

CSACV_X_Q

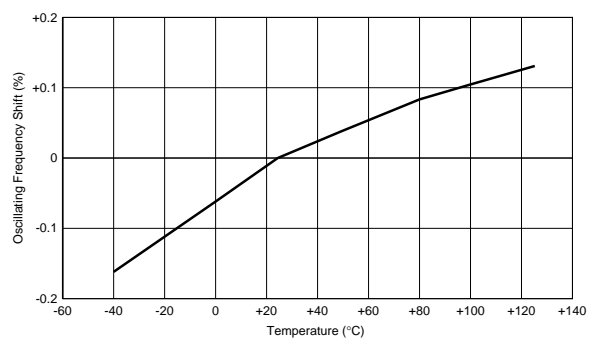

Application Circuits Utilization

2

■ uPD78F9222MC-5A4 (NEC Electronics)

8-bit Microcomputer

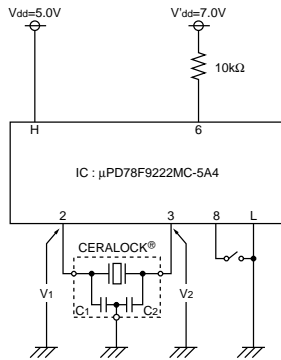

H: 5, 20
L: 1

CERALOCK®: CSTCR6M00G55B-R0
C1=39pF (Typ.)
C2=39pF (Typ.)

■ M30260F8AGP (Renesas)

16-bit Microcomputer

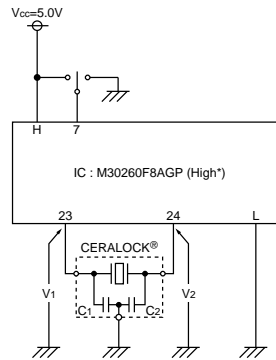

H: 11, 46, 47, 48
L: 4, 9, 44

*High: XIN-XOUT Drive Capacity Select Bit

CERALOCK®: CSTCE10M0G55A-R0
C1=33pF (Typ.)
C2=33pF (Typ.)

■ MB90F347D (Fujitsu)

16-bit Microcomputer

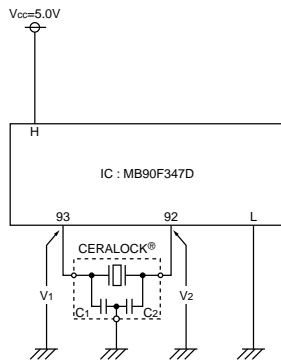

H: 15, 32, 65, 90
L: 16, 35, 44, 66, 91

CERALOCK®: CSTCE8M00G55A-R0
C1=33pF (Typ.)
C2=33pF (Typ.)

■ MC68HC908AZ60AVFU (Freescale)

8-bit Microcomputer

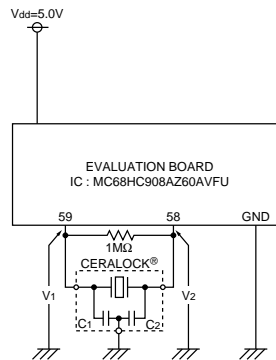

CERALOCK®: CSTCE16M0V53C-R0
C1=15pF (Typ.)
C2=15pF (Typ.)

■ ST72F324J6T3 (MS) (ST Microelectronics)

8-bit Microcomputer

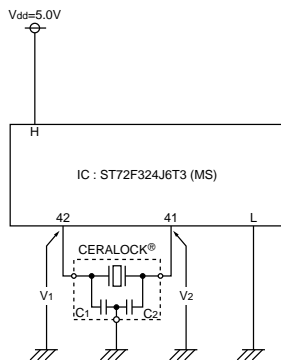

H: 13, 21, 32, 43
L: 14, 22, 33, 39, 40

CERALOCK®: CSTCR4M00G55B-R0
C1=39pF (Typ.)
C2=39pF (Typ.)

■ PIC12F675-I/P (HS) (Microchip)

8-bit Microcomputer

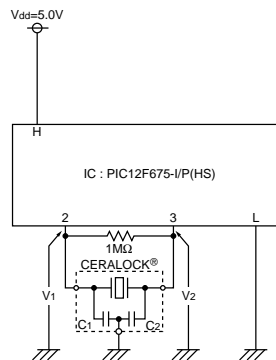

H: 1
L: 4, 8

CERALOCK®: CSTCE8M00G52A-R0
C1=10pF (Typ.)
C2=10pF (Typ.)

MHz Chip Type Notice (Soldering and Mounting) for Automotive

■ CSTCC/CSTCR/CSTCE_V/CSTCE_G/CSTCV/CSACV Series

1. Soldering Conditions

(1) Reflow

One heat stress, shown in the profile at right, is applied to resonator; then, after being placed in natural conditions for 1 hour, the resonator is measured.

(a) Pre-heating conditions should be +150 to +180°C for 60 to 120 seconds. Ascending time up to +150°C should be longer than 30 seconds.

(b) Heating conditions should be within 40 seconds at +230°C min., but peak temperature should be lower than +260°C.

(2) Soldering Iron

Components shall be measured after soldering on PCB at +350±5°C for 3.0±0.5 seconds and leaving in natural condition for 24 hours. The soldering iron shall not touch the components while soldering.

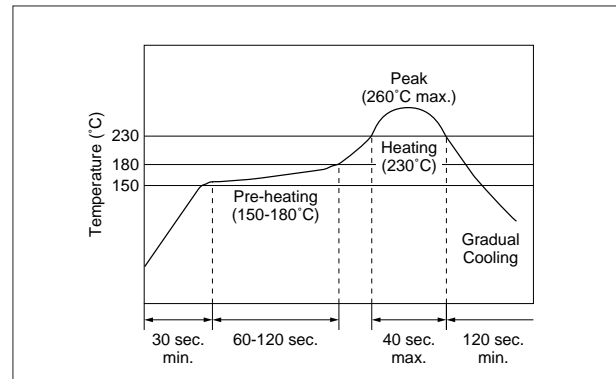

2. Wash

(1) Cleaning Solvents

HCFC, Isopropanol, Tap water, Demineralized water, Cleanthrough750H, Pine alpha 100S, Techno care FRW

(2) Temperature Difference : dT *1

$dT \leq 60^\circ\text{C}$ ($dT = \text{Component} - \text{solvent}$)

*1 ex. In case the component at +90°C immerses into cleaning solvent at +60°C, then $dT = 30^\circ\text{C}$.

(3) Conditions

(a) Ultrasonic Wash

1 minute max. in above solvent at +60°C max.

(Frequency: 28kHz, Output: 20W/l)

(b) Immersion Wash

5 minutes max. in above solvent at +60°C max.

(c) Shower or Rinse Wash

5 minutes max. in above solvent at +60°C max.

(4) Drying

5 minutes max. by air blow at +80°C max.

(5) Others

(a) Total washing time should be within 10 minutes.

(b) The component may be damaged if it is washed with chlorine, petroleum, or alkali cleaning solvent.

3. Notice for Mounting

(a) The component is recommended for use with placement machines which employ optical placement capabilities. The component might be damaged by excessive mechanical force. Please make sure to evaluate by using placement machines before going into mass production. Do not use placement machines which utilize mechanical positioning. Please contact Murata for details beforehand.

(b) Please insure the component is thoroughly evaluated in your application circuit.

(c) Please do not apply excess mechanical stress to the component and terminals during soldering.

MHz Chip Type Notice for Automotive

■ Notice (Storage and Operating Conditions)

1. Product Storage Condition

Please store the products in room where the temperature/humidity is stable. And avoid such places where there are large temperature changes. Please store the products under the following conditions:

Temperature: -10 to + 40 degrees C

Humidity: 15 to 85% R.H.

2. Expire Date on Storage

Expire date (Shelf life) of the products is six months after delivery under the conditions of a sealed and an unopened package. Please use the products within six months after delivery. If you store the products for a long time (more than six months), use carefully because the products may be degraded in the solderability and/or rusty. Please confirm solderability and characteristics for the products regularly.

3. Notice on Product Storage

- (1) Please do not store the products in a chemical atmosphere (Acids, Alkali, Bases, Organic gas, Sulfides and so on), because the characteristics may be reduced in quality, and/or be degraded in the solderability due to the storage in a chemical atmosphere.

- (2) Please do not put the products directly on the floor without anything under them to avoid damp places and/or dusty places.

- (3) Please do not store the products in the places such as: in a damp heated place, in a place where direct sunlight comes in, in place applying vibrations.

- (4) Please use the products immediately after the package is opened, because the characteristics may be reduced in quality, and/or be degraded in the solderability due to storage under the poor condition.

- (5) Please do not drop the products to avoid cracking of ceramic element.

4. Others

Conformal coating of the component is acceptable. However, the resin material, curing temperature, and other process conditions should be evaluated to confirm that stable electrical characteristics are maintained.

Please be sure to consult with our sales representative or engineer whenever and prior to using the products.

■ Notice (Rating)

The component may be damaged if excess mechanical stress is applied.

■ Notice (Handling)

"CERALOCK" may stop oscillating or oscillate irregularly under improper circuit conditions.

MHz Chip Type Packaging for Automotive

Minimum Quantity

Part Number	Plastic Tape ø180mm	Plastic Tape ø330mm	Bulk	Dimensions
CSTCC_G_A	2,000	6,000	500	a
CSTCR_G_B	3,000	9,000	500	a
CSTCR_G15C	3,000	9,000	500	a
CSTCE_G_A	3,000	9,000	500	b
CSTCE_G15C	3,000	9,000	500	b
CSTCE_V_C	3,000	9,000	500	b
CSTCE_V13C	3,000	9,000	500	b
CSTCV_X_Q	2,000	6,000	500	a
CSACV_X_Q	2,000	6,000	500	a

The order quantity should be an integral multiple of the "Minimum Quantity" shown above.

(pcs.)

Dimensions of Reel

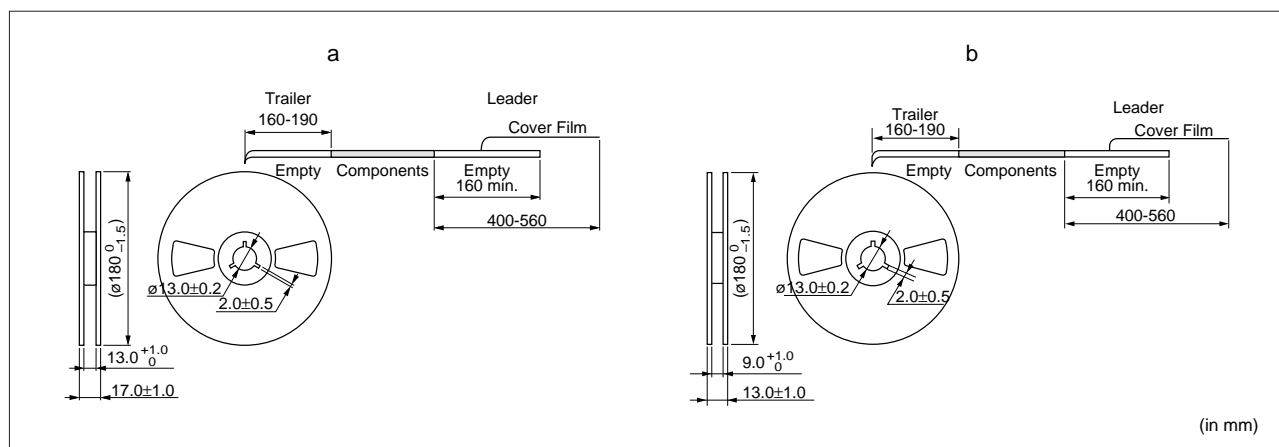

Dimensions of Taping

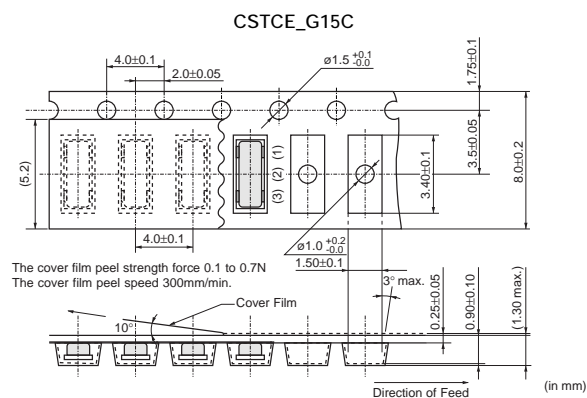
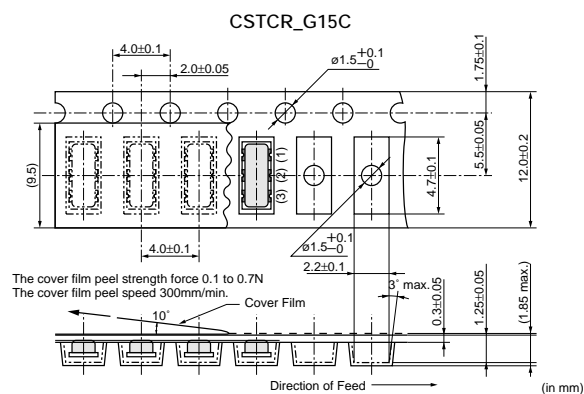

Continued on the following page. ↗

MHz Chip Type Packaging for Automotive

Continued from the preceding page.

■ Dimensions of Taping

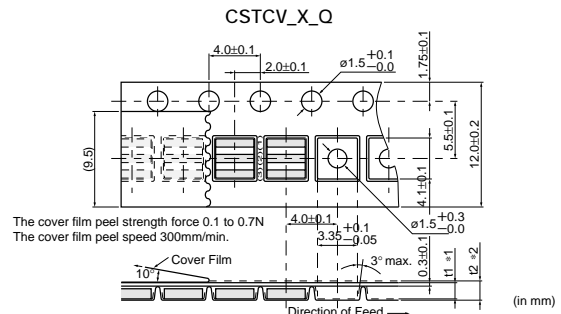
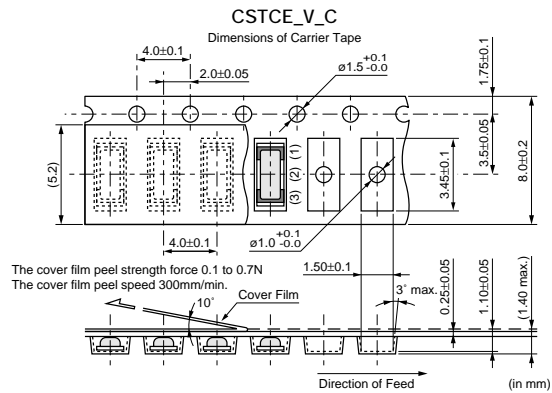
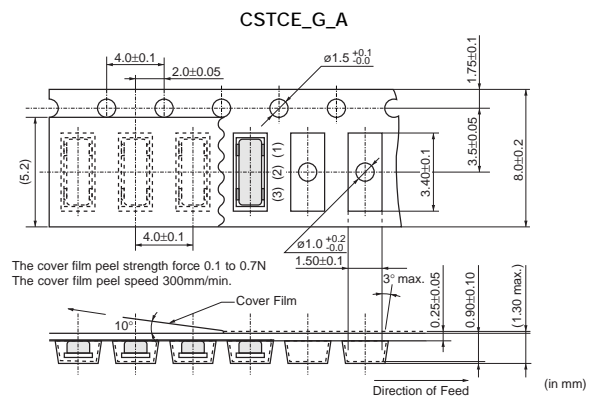
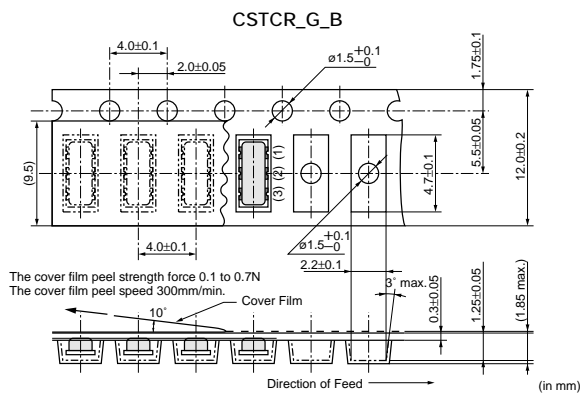
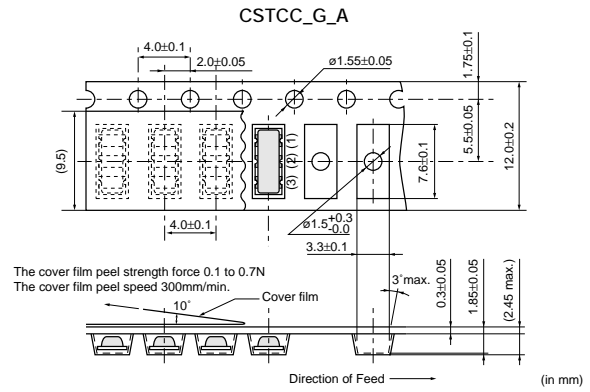
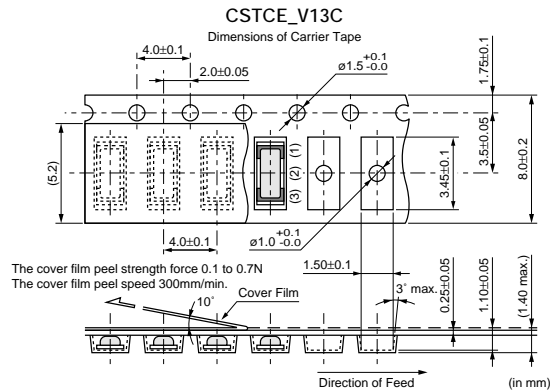

*1, *2: Dimensions vary with product thickness of CERALOCK®

Thickness of CERALOCK®	1.50-1.40	1.30-1.20	1.10-1.00
t1	*1	1.65±0.1	1.45±0.1
t2	*2	2.0 max.	1.8 max.

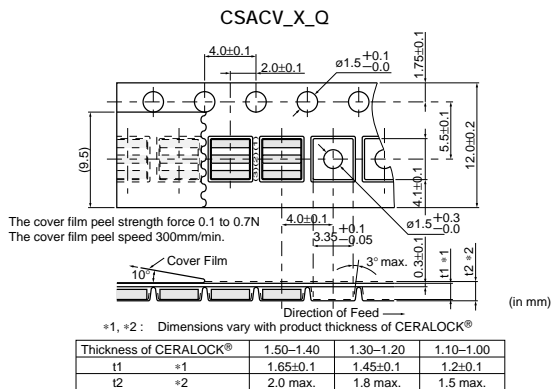

*1, *2: Dimensions vary with product thickness of CERALOCK®

Thickness of CERALOCK®	1.50-1.40	1.30-1.20	1.10-1.00
t1	*1	1.65±0.1	1.45±0.1
t2	*2	2.0 max.	1.8 max.

Ceramic Resonators (CERALOCK®)



MHz Chip Type - Tight Frequency Tolerance for General Usage-

3

Chip type "CERALOCK" with built-in load capacitors in an extremely small package provides high accuracy. MURATA's frequency adjustment and package technology expertise has enabled the development of the chip "CERALOCK" with built-in load capacitors. High-density mounting can be realized because of the small package and the elimination of the need for an external load capacitor.

■ Features

1. High accuracy resonator realizes initial tolerance of ± 250 ppm.
2. Oscillation circuits do not require external load capacitors.
3. The series is available in a wide frequency range.
4. The resonators are extremely small and have a low profile.
5. No adjustment is necessary for oscillation circuits.

■ Applications

1. Clock oscillators for USB (High-speed and Full-speed) controller ICs
2. Storage devices with SATA interface (HDD, Optical storage device, etc.)
3. Audio equipment and musical instrument, etc.
4. Other applications for replacement from Crystal Oscillators



CSTCR_G15L
4.00-7.99MHz

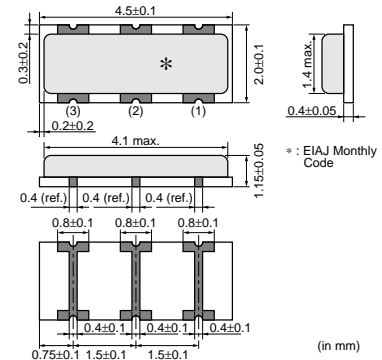

CSTCE_G15L
8.00-13.99MHz

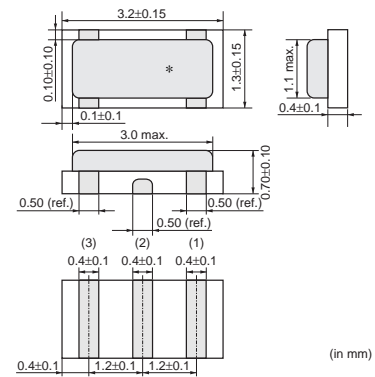

CSTCE_V13L
14.00-20.00MHz

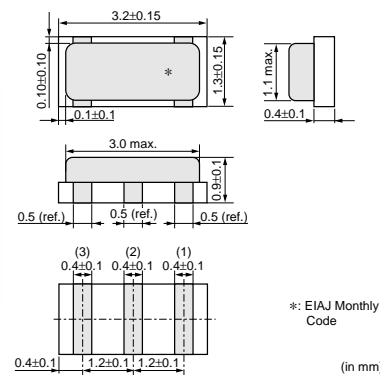

CSTCE_XK, CSTCE_XT
24.00-27.20/30.00MHz

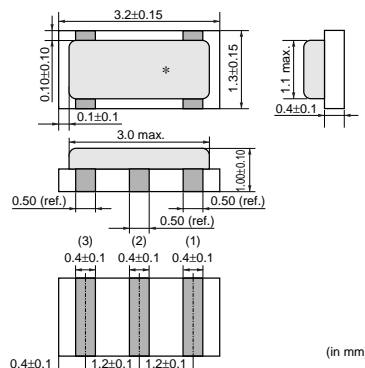

CSTCW_X11
20.01-29.99MHz

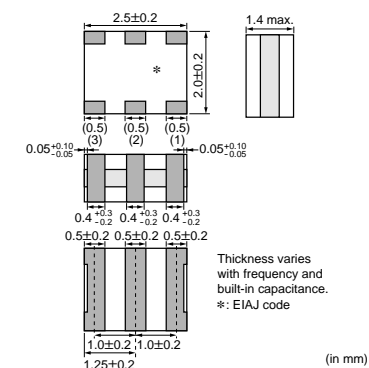

Continued on the following page. ↗

Continued from the preceding page.

CSTCZ_X12R
30.00-48.00MHz

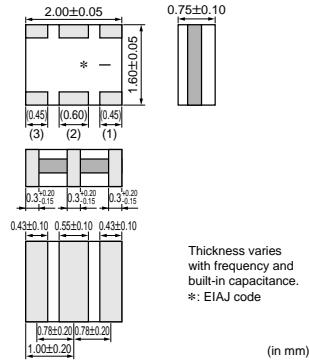

Part Number	Oscillating Frequency (MHz)	Initial Tolerance	Temp. Stability (%)	Temperature Range (°C)
CSTCR_G15L	4.00 to 7.99	±0.1%	±0.08	0 to 70
CSTCE_G15L	8.00 to 13.99	±0.1%	±0.08	0 to 70
CSTCE_V13L	14.00 to 20.00	±0.1%	±0.08	0 to 70
CSTCW_X11	20.01 to 29.99	±0.1%	±0.1	0 to 70
CSTCE_XK	24.00 to 27.20 /30.00	+0.02 /-0.025%	±0.015	0 to 70
CSTCE_XT	24.00 to 27.20 /30.00	±0.027%	±0.015	0 to 70
CSTCZ_X12R	30.00 to 48.00	±0.15%	±0.05 [0 to 70°C:±0.03%]	-30 to 85

CSTCE_XK: Available Frequency is 24.00 to 27.20MHz and 30.00MHz.
 CSTCE_XT: Initial tol. Includes freq. aging. Please contact us in case temp. range exceeds 0 to 70 degrees C.
 Irregular or stop oscillation may occur under unmatched circuit conditions. Please check the actual conditions prior to use.

■ Oscillation Frequency Measuring Circuit

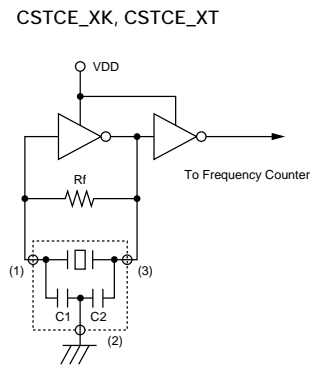
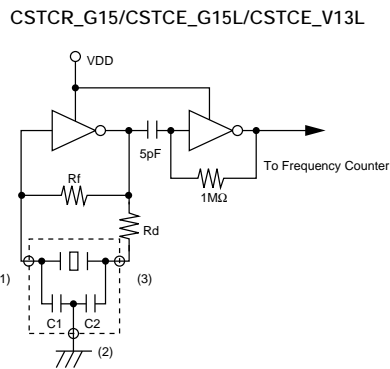

Continued on the following page. ↗

Continued from the preceding page.

■ Oscillation Frequency Measuring Circuit

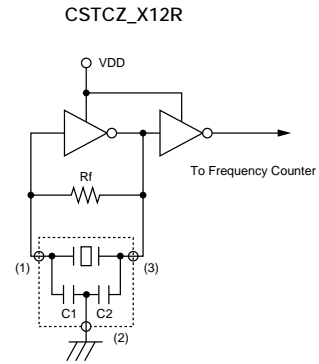
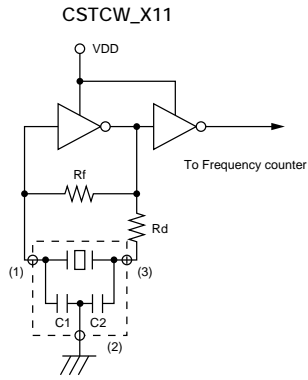

3

■ Standard Land Pattern Dimensions

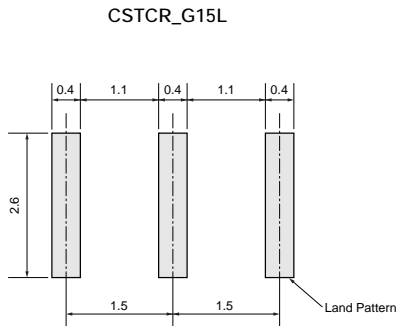

(in mm)

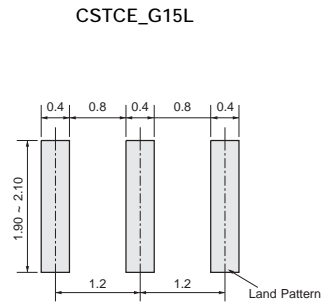

(in mm)

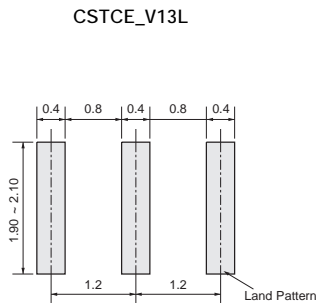

(in mm)

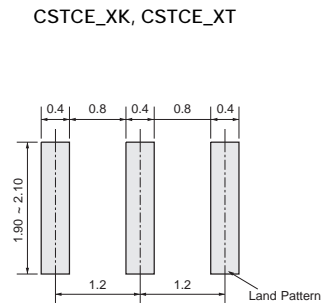

(in mm)

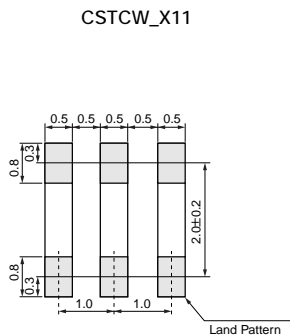

(in mm)

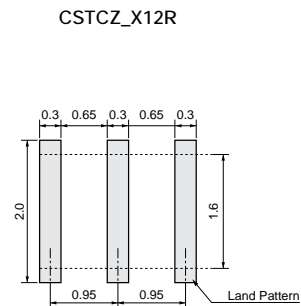

(in mm)

■ Oscillation Frequency Temperature Stability

CSTCR_G15L

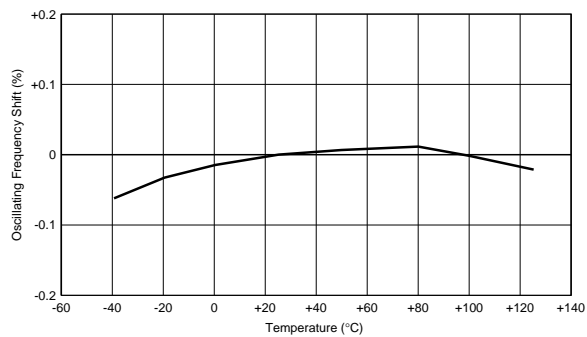

CSTCE_G15L

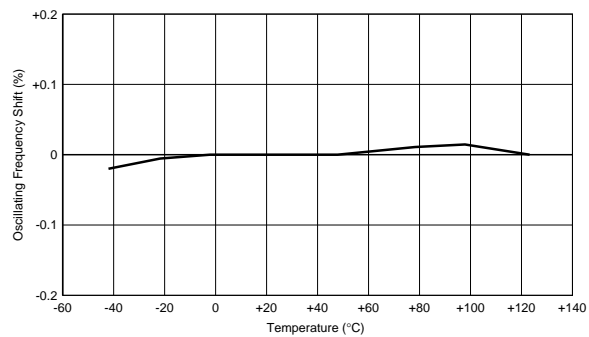

CSTCE_V13L

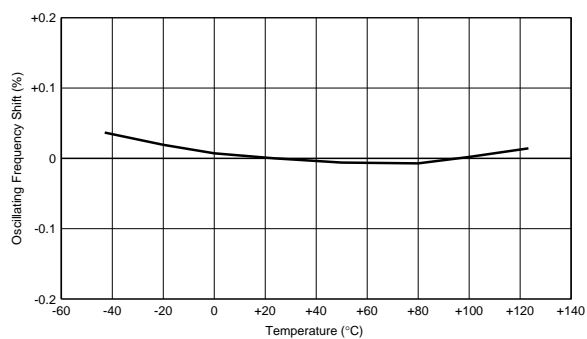

CSTCE_XK, CSTCE_XT

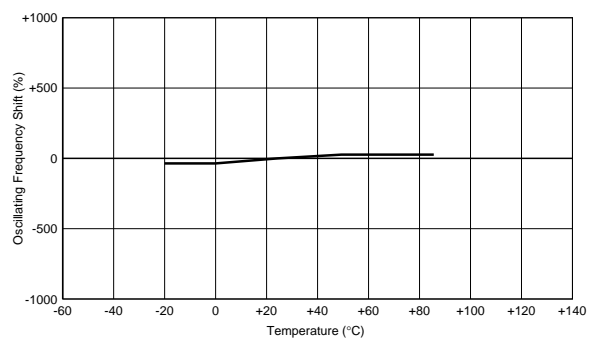

CSTCW_X11

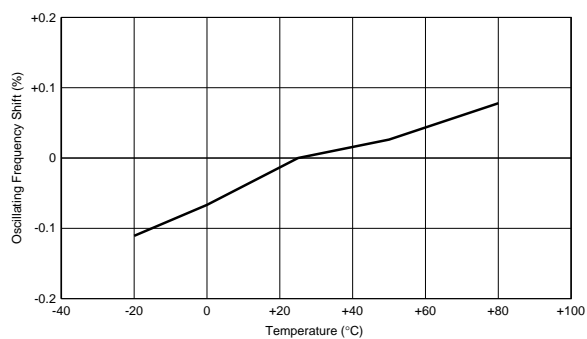

CSTCZ_X12R

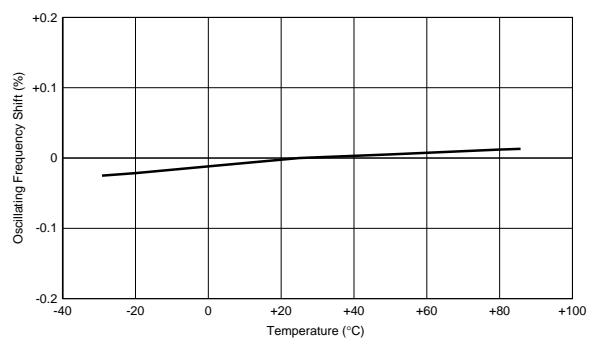

Application Circuits Utilization

3

■ M66291GP (Renesas)

USB Transceiver

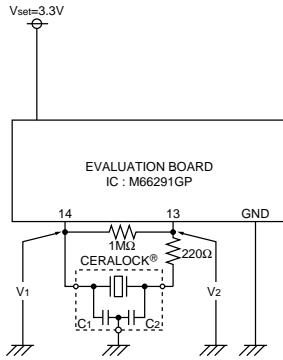

CERALOCK®: CSTCR6M00G15□□□-R0
 C1=39pF (Typ.)
 C2=39pF (Typ.)

■ MN102HF74GHL (Panasonic)

16-bit Microcontroller

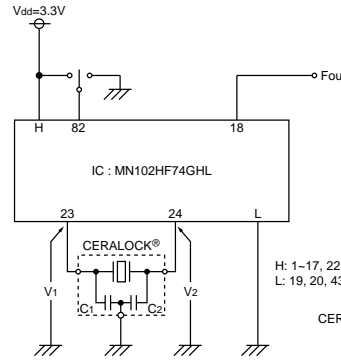

H: 1-17, 22, 25, 26-42, 54, 58-60, 66-81, 83-91
 L: 19, 20, 43-53, 55-57, 61-65, 82, 92-100

CERALOCK®: CSTCE12MOG15L□□□-R0
 C1=33pF (Typ.)
 C2=33pF (Typ.)

■ LC87F1964A (Sanyo)

8-bit Microcontroller

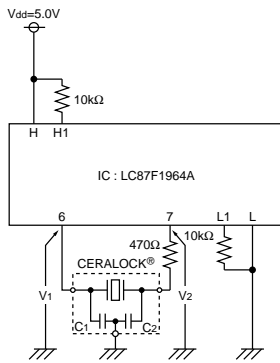

H: 8, 19, 39
 L: 5, 20, 40
 H1: 31, 33
 L1: 29, 30, 32, 34-36

CERALOCK®: CSTCE12MOG15L□□□-R0
 C1=33pF (Typ.)
 C2=33pF (Typ.)

■ TUSB2046B (Texas Instruments)

USB 4-port HUB

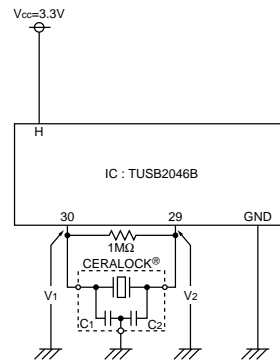

H: 3, 25
 L: 7, 28

CERALOCK®: CSTCR6M00G15□□□-R0
 C1=39pF (Typ.)
 C2=39pF (Typ.)

■ ISP1181BDGG (Philips)

USB Controller

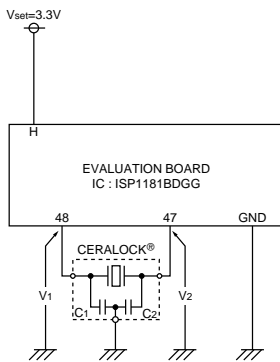

CERALOCK®: CSTCR6M00G15□□□-R0
 C1=39pF (Typ.)
 C2=39pF (Typ.)

■ uPD720114 (NEC Electronics)

USB2.0 (Hi-speed) HUB Controller

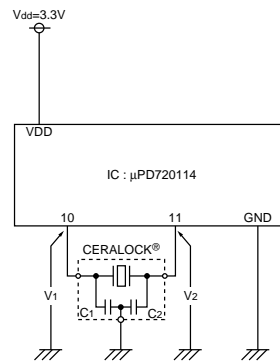

CERALOCK®: CSTCE30M0XK1□□□-R0
 C1=5pF (Typ.)
 C2=5pF (Typ.)

Ceramic Resonators (CERALOCK®)



MHz Chip Type -Standard Frequency Tolerance for General Usage-

Chip type "CERALOCK" with built-in load capacitors provides extremely small package. MURATA's package technology expertise has enabled the development of the Chip "CERALOCK" with built-in load capacitors. High-density mounting can be realized because of the small package and the elimination of the need for an external load capacitor.

■ Features

1. Oscillation circuits do not require external load capacitors.
2. The series is available in a wide frequency range.
3. The resonators are extremely small and have a low profile.
4. No adjustment is necessary for oscillation circuits.

■ Applications

1. Clock oscillators for microprocessors
2. Small electronic equipment such as hand held phone, digital video camcorder (DVC), digital still camera (DSC), portable audio player, etc.
3. Storage media and memory (HDD, Optical storage device, FDD, Flash memory card, etc.)
4. Office automation equipment (Mobile PC, Mouse, Keyboard, etc.)
5. Audio-visual applications (TV, DVD-HDD recorder, Audio equipment, Remote controller, etc.)
6. Home appliances (Air conditioner, Microwave oven, Refrigerator, Washing machine, etc.)



CSTCC_G
2.00-3.99MHz

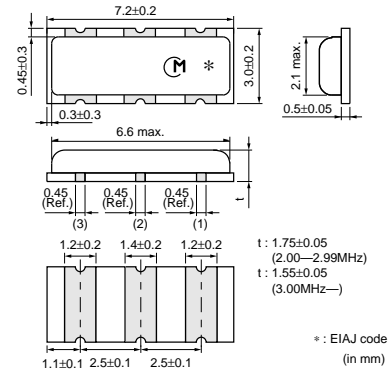

CSTCR_G
4.00-7.99MHz

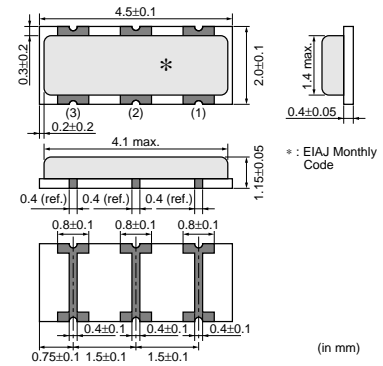

CSTCE_G
8.00-13.99MHz

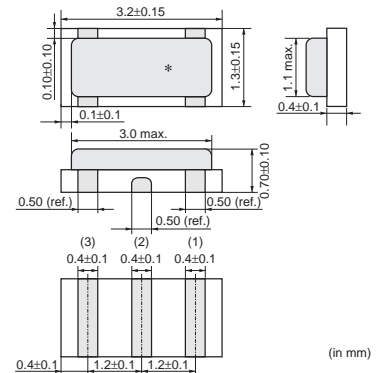

CSTCE_V
14.00-20.00MHz

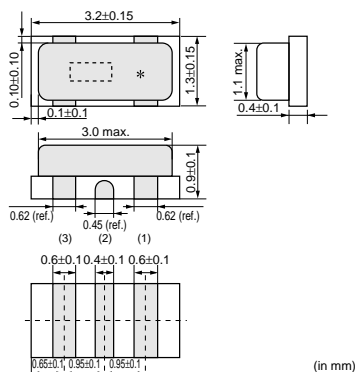

CSTCG_V
20.00-33.86MHz
(Ultra Small)

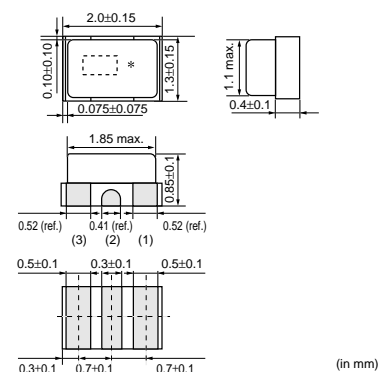

Continued on the following page. ↗

4

Continued from the preceding page.

CSACW_X
20.01-70.00MHz

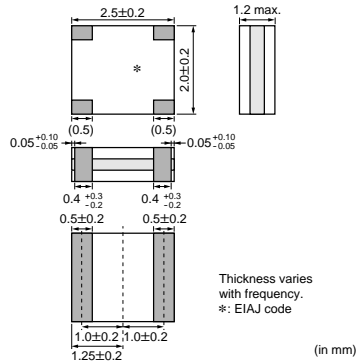

CSTCW_X
20.01-70.00MHz

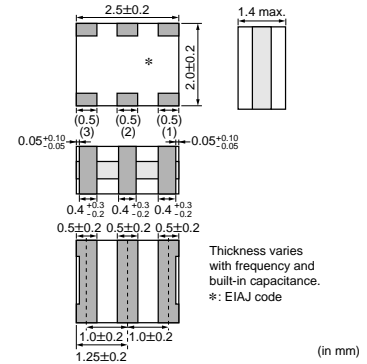

4

CSTCW_X_M
25.00-48.00MHz
(Ultra Thin)

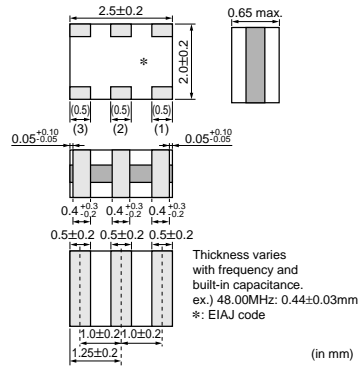

Part Number	Oscillating Frequency (MHz)	Initial Tolerance	Temp. Stability (%)	Temperature Range (°C)
CSTCC_G	2.00 to 3.99	±0.5%	±0.3 [±0.4%:Built-in Capacitance 47pF type within Freq.2.00 to 3.49MHz]	-20 to 80
CSTCR_G	4.00 to 7.99	±0.5%	±0.2	-20 to 80
CSTCE_G	8.00 to 13.99	±0.5%	±0.2	-20 to 80
CSTCE_G_Z	8.00 to 13.99	±0.5%	±0.2	-40 to 125
CSTCE_V	14.00 to 20.00	±0.5%	±0.3	-20 to 80
CSTCG_V	20.00 to 33.86	±0.5%	±0.3	-20 to 80
CSACW_X	20.01 to 70.00	±0.5%	±0.2	-20 to 80
CSTCW_X	20.01 to 70.00	±0.5%	±0.2	-20 to 80
CSTCW_X_M	25.00 to 48.00	±0.5%	±0.2	-20 to 80

Irregular or stop oscillation may occur under unmatched circuit conditions. Please check the actual conditions prior to use.

■ Oscillation Frequency Measuring Circuit

CSTCR_G/CSTCE_G/CSTCE_V/CSTCG_V

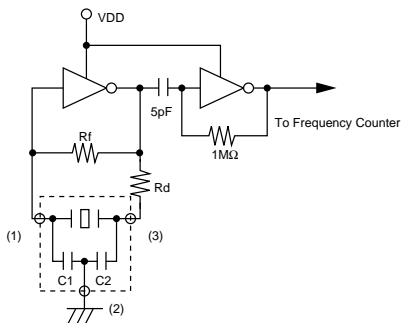

CSTCC_G/CSTCW_X

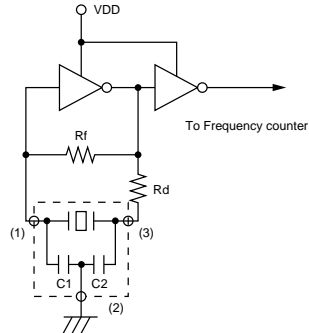

CSACW_X

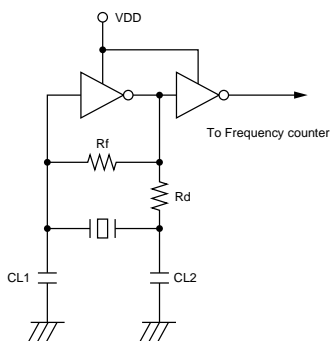

CSTCW_X_M

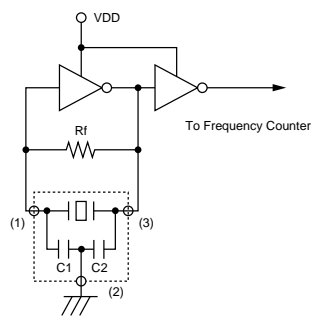

4

Standard Land Pattern Dimensions

CSTCC_G

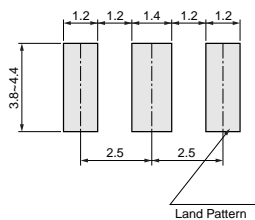

(in mm)

CSTCR_G

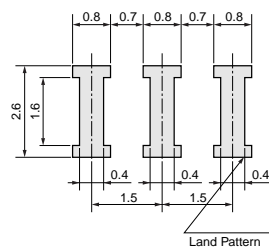

(in mm)

CSTCE_G

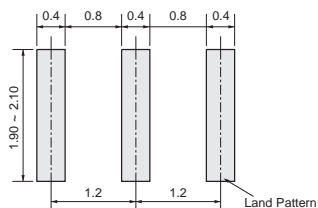

(in mm)

CSTCE_V

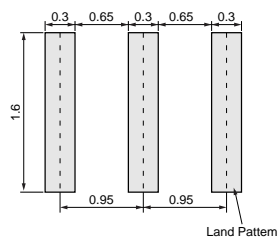

(in mm)

CSTCG_V

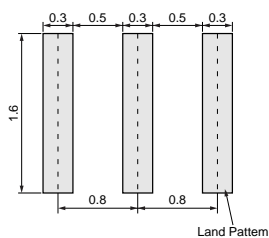

(in mm)

CSACW_X

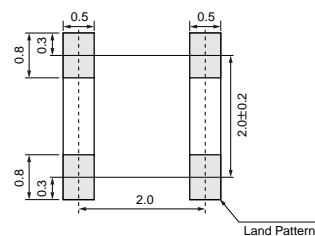

(in mm)

CSTCW_X

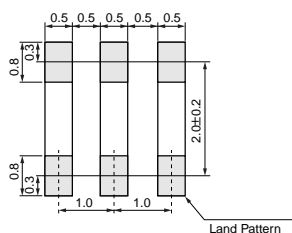

(in mm)

CSTCW_X_M

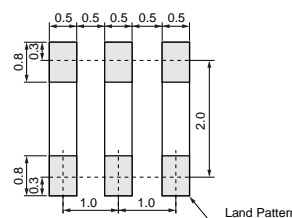

(in mm)

■ Oscillation Frequency Temperature Stability

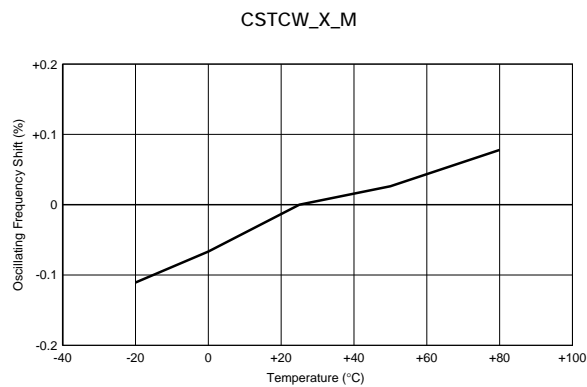
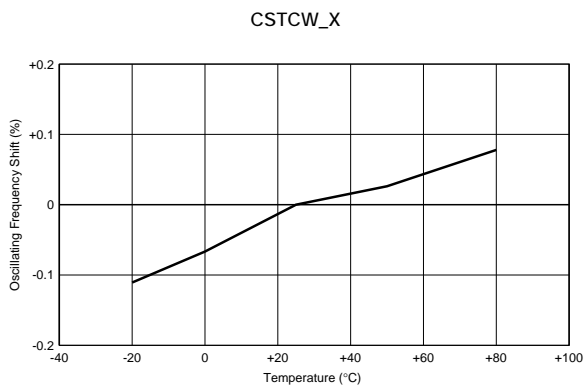
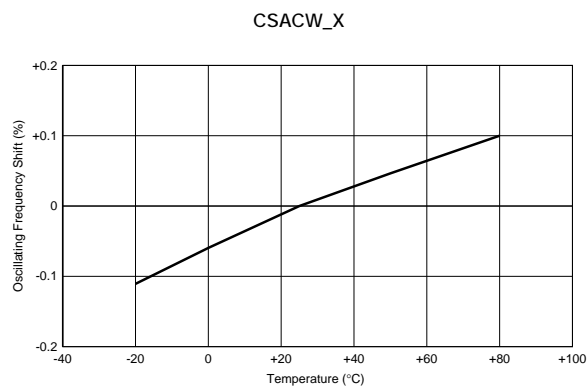
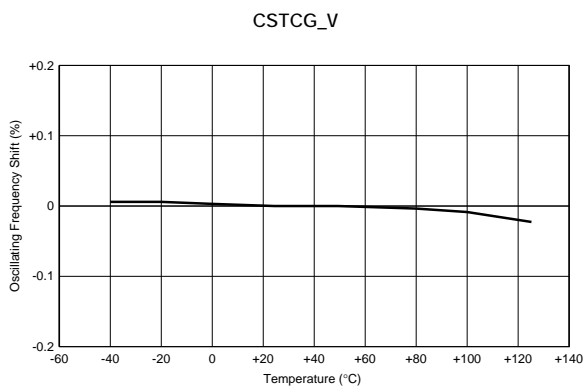
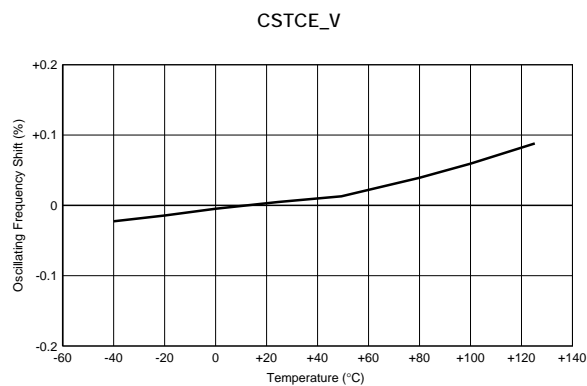
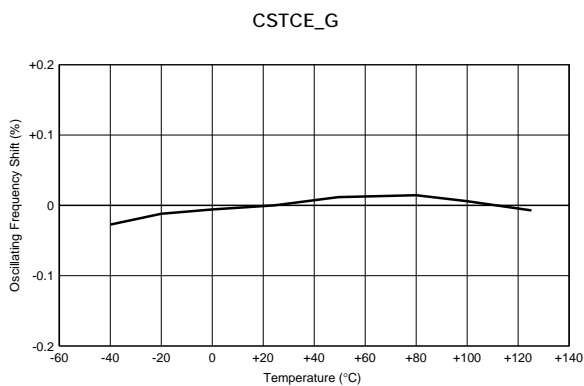
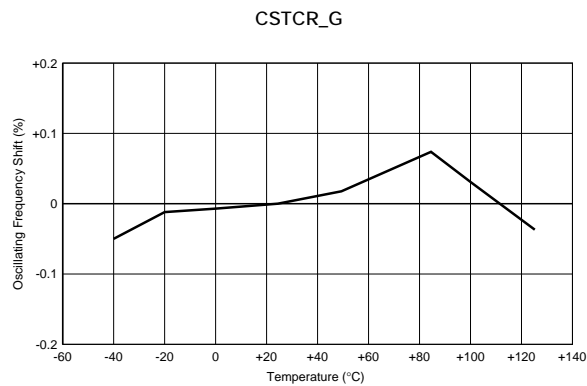
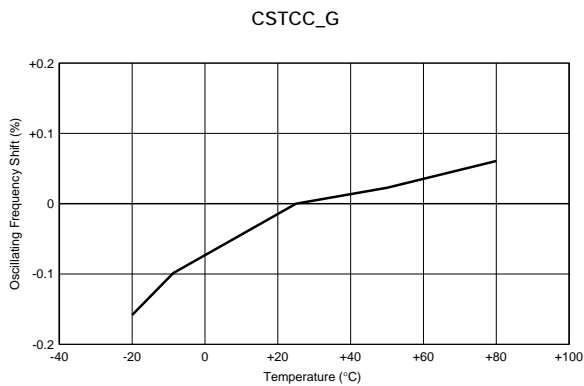

4

Application Circuits Utilization

■ uPD78F0533GB (NEC Electronics)

8-bit Microcomputer

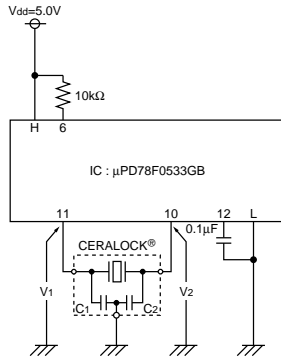

H: 15, 16, 47
L: 9, 13, 14, 48

CERALOCK®: CSTCR4M00G55-R0
C1=39pF (Typ.)
C2=39pF (Typ.)

■ M38235G6HP (Renesas)

8-bit Microcomputer

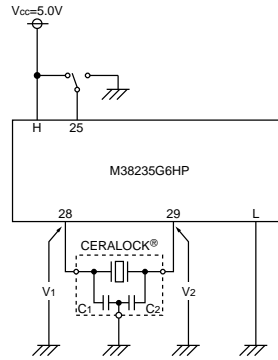

H: 71
L: 30, 73

CERALOCK®: CSTLS8M00G53-B0
C1=15pF (Typ.)
C2=15pF (Typ.)

■ TMP19A43FDXBG (Toshiba)

32-bit Microcomputer

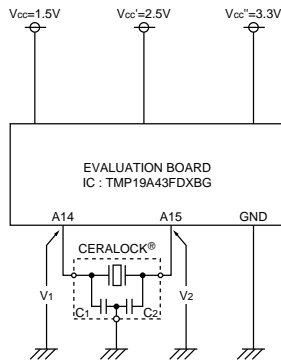

Xin: A14
Xout: A15

CERALOCK®: CSTCE10M0G52-R0
C1=10pF (Typ.)
C2=10pF (Typ.)

■ MN103SFC2D (Panasonic)

32-bit Microcomputer

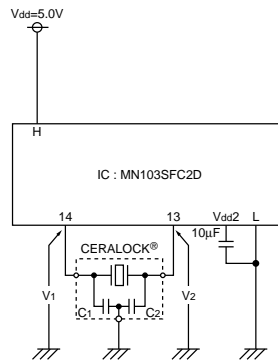

H: 9, 17, 34
L: 7, 15, 36
Vdd2: 16, 38

CERALOCK®: CSTCR5M00G56Z-R0
C1=39pF (Typ.)
C2=39pF (Typ.)

■ MB95F128H (Fujitsu)

8-bit Microcomputer

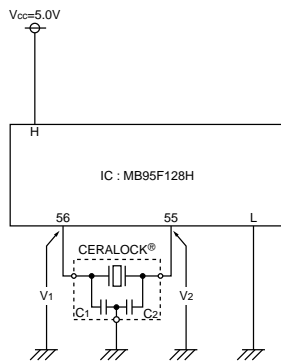

H: 3, 28, 51, 79
L: 4, 29, 54, 57

CERALOCK®: CSTCE8M00G52-R0
C1=10pF (Typ.)
C2=10pF (Typ.)

■ PIC16F716-I/SO (Microchip)

8-bit Microcomputer

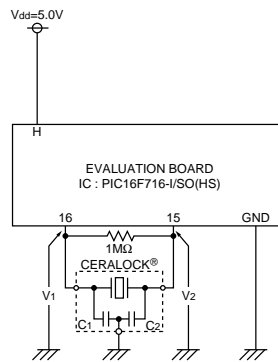

CERALOCK®: CSTCE12M0G52A-R0
C1=10pF (Typ.)
C2=10pF (Typ.)

Continued on the following page. ↗

Application Circuits Utilization

Continued from the preceding page.

HD64F36077GH (Renesas)

16-bit Microcomputer

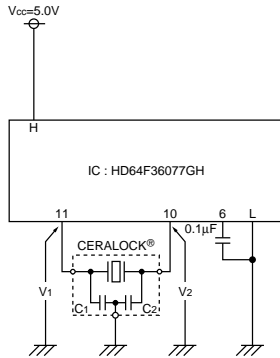

H: 3, 7, 12
L: 8, 9

CERALOCK®: CSTCE8M00G52-R0
C1=10pF (Typ.)
C2=10pF (Typ.)

LC87F5G32A (Sanyo)

8-bit Microcomputer

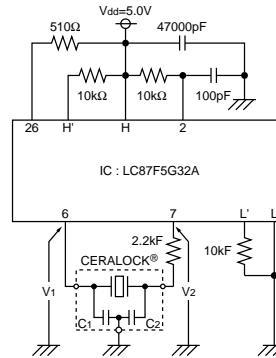

H: 8, 19, 39
L: 5, 20, 40
H': 29, 31, 35
L': 30, 32-34, 36

CERALOCK®: CSTLS5M00G53-B0
C1=15pF (Typ.)
C2=15pF (Typ.)

µPD70F3215HYGC (NEC Electronics)

32-bit Microcomputer

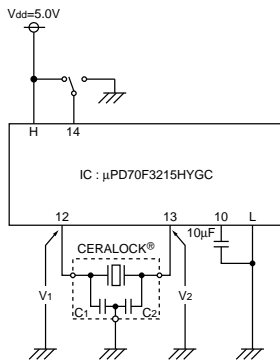

H: 1, 5, 9, 34, 70
L: 2, 8, 11, 33, 69

CERALOCK®: CSTCR5M00G55-R0
C1=39pF (Typ.)
C2=39pF (Typ.)

ATmega128 (Atmel)

8-bit Microcomputer

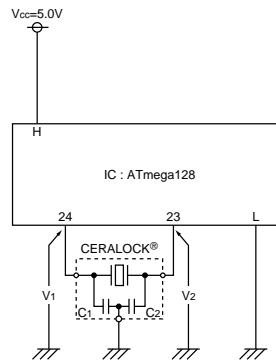

H: 21, 52, 64
L: 22, 53, 63

CERALOCK®: CSTCE8M00G52-R0
C1=10pF (Typ.)
C2=10pF (Typ.)

ST7FLITE29F2B6 (ST Microelectronics)

8-bit Microcomputer

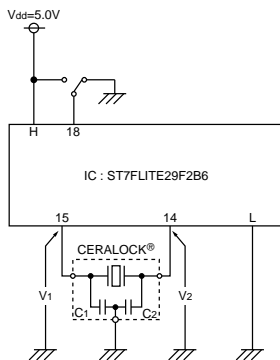

H: 17
L: 16

CERALOCK®: CSTCE16M0V53-R0
C1=15pF (Typ.)
C2=15pF (Typ.)

TMS320F2810PBKA (Texas Instrumets)

32-bit Microcomputer

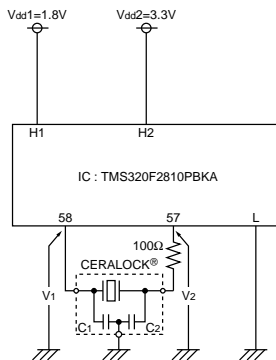

H1: 20, 29, 42, 56, 63, 74, 82, 94, 99,
100, 102, 110, 114
H2: 1, 13, 14, 25, 49, 52, 83, 104, 118
L: 12, 15, 17, 26, 30, 39, 53, 59, 62, 73,
88, 95, 103, 109, 115, 117, 128

CERALOCK®: CSTCE15M0V53-R0
C1=15pF (Typ.)
C2=15pF (Typ.)

Ceramic Resonators (CERALOCK®)



MHz Lead Type -Standard Frequency Tolerance for General Usage-

MURATA's ceramic resonator, "CERALOCK" with built-in load capacitors, has been widely applied as the most suitable component for clock oscillators in a broad range of microprocessors. The CSTLS series can be used in the design of oscillation circuits not requiring external load capacitors, enabling both high-density mounting and cost reduction.

■ Features

1. Oscillation circuits do not require external load capacitors.
There is some variation in built-in capacitance values applicable to various IC (except for CSALS series).
2. The series is stable over a wide temperature range.
3. The resonators are compact, lightweight and exhibit superior shock resistance performance.
4. They enable the design of oscillator circuits requiring no adjustment.
5. The series is inexpensive and available in stable supply.

■ Applications

1. DTMF generators
2. Clock oscillators for microcomputers
3. Remote control units
4. Automated office equipment

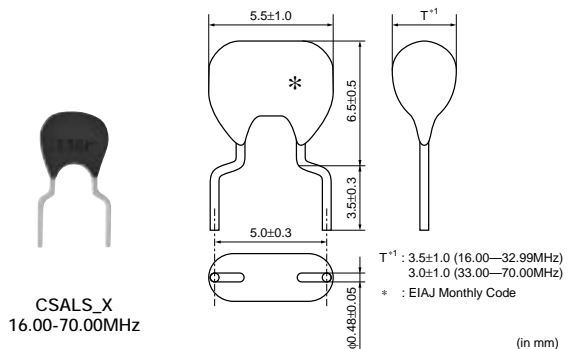
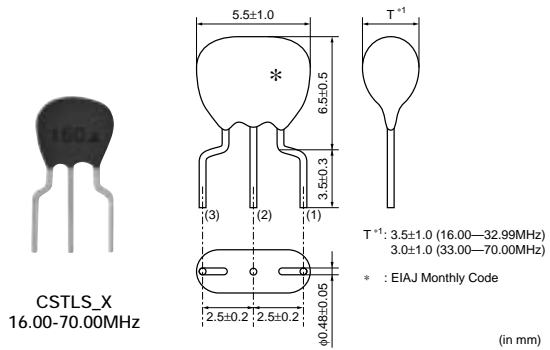
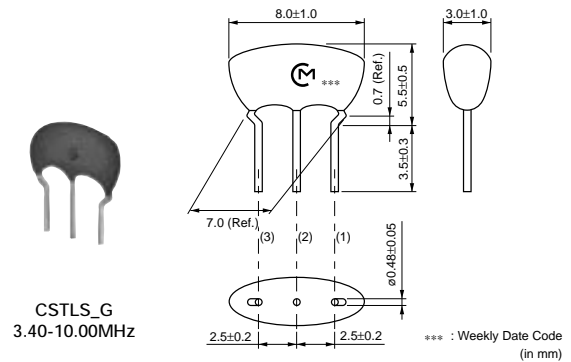

Part Number	Oscillating Frequency (MHz)	Initial Tolerance	Temp. Stability (%)	Temperature Range (°C)
CSTLS_G	3.40 to 10.00	±0.5%	±0.2 [-0.4% to +0.2%:Built-in Capacitance 47pF type]	-20 to 80
CSALS_X	16.00 to 70.00	±0.5%	±0.2	-20 to 80
CSTLS_X	16.00 to 70.00	±0.5%	±0.2	-20 to 80

Irregular or stop oscillation may occur under unmatched circuit conditions. Please check the actual conditions prior to use.
 The order quantity should be an integral multiple of the "Minimum Quantity" shown in the packaging page.

■ Oscillation Frequency Measuring Circuit

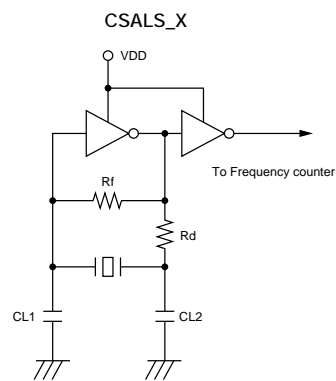
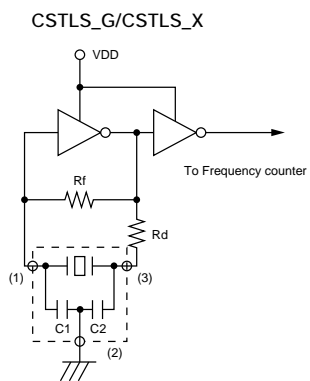

■ Oscillation Frequency Temperature Stability

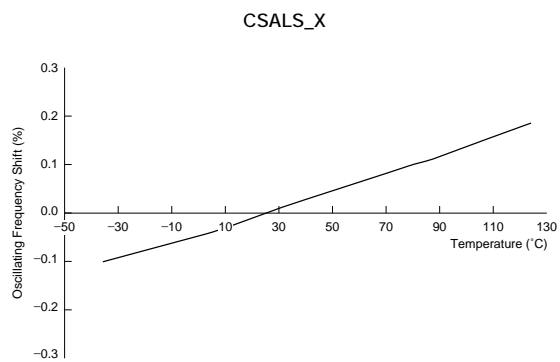
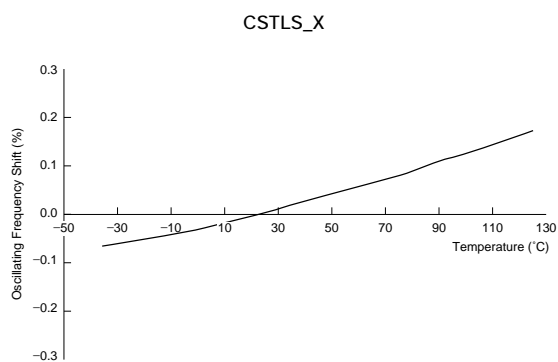
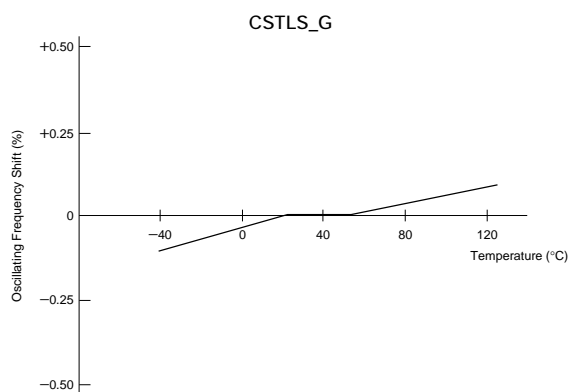

Ceramic Resonators (CERALOCK®)



kHz Chip Type -Standard Frequency Tolerance for General Usage-

MURATA's original package technologies have enabled the development of the kHz band "CERALOCK". The series is perfect in miniature remote control units and AV modules. "CERALOCK" can be reflow soldered and mounted by automatic placers.

■ Features

1. The series withstands reflow soldering.
2. The series is mountable by automatic placers.
3. No adjustment is necessary for oscillation circuits.

■ Applications

1. Clock oscillators for microprocessors
2. OA equipment
3. AV modules



CSBFB_J
430-519kHz

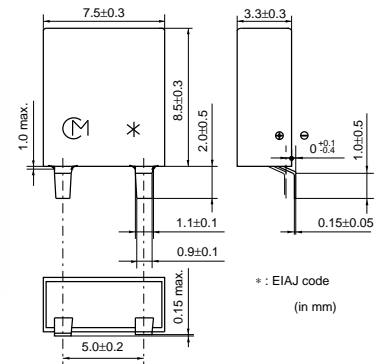

CSBFB_J
700-1250kHz

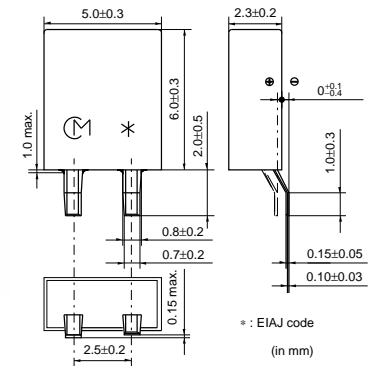

6

Part Number	Oscillating Frequency (kHz)	Initial Tolerance	Temp. Stability (%)	Temperature Range (°C)
CSBFB_J	430 to 519, 700 to 1250	±0.5%	±0.3	-20 to 80

Irregular or stop oscillation may occur under unmatched circuit conditions. Please check the actual conditions prior to use.

■ Oscillation Frequency Measuring Circuit

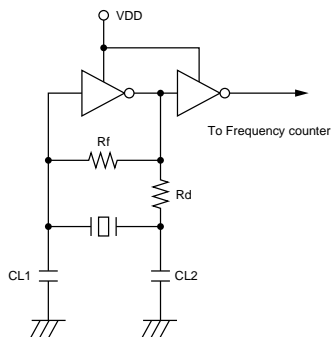

■ Oscillation Frequency Temperature Stability

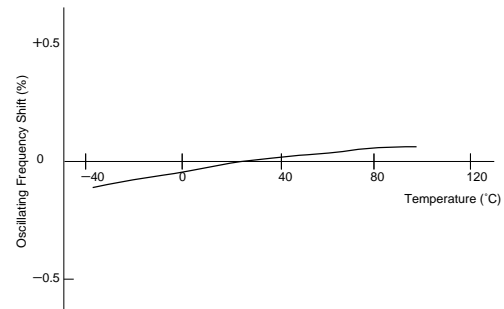

Continued on the following page. ↗

Continued from the preceding page.

Standard Land Pattern Dimensions

CSBFB_J (430-519kHz)

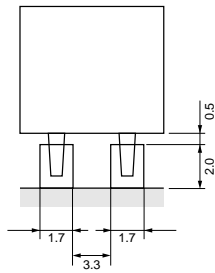

(in mm)

CSBFB_J (700-1250kHz)

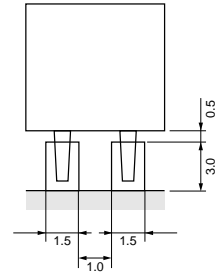

(in mm)

Ceramic Resonators (CERALOCK®)



kHz Lead Type -Standard Frequency Tolerance for General Usage-

The CSBLA series ceramic resonators owe their development to MURATA's innovative expert technologies and the application of mass production techniques typically utilized in the manufacture of piezoelectric ceramic components. Because of their high mechanical Q and consistent high quality, the CSBLA series are ideally suited to microprocessor and remote control unit applications.

■ Features

1. The series is stable over a wide temperature range and with respect to long-term aging.
2. The series comprises fixed, tuned, solid-state devices.
3. The resonators are miniature and lightweight.
4. They exhibit excellent shock resistance performance.
5. Oscillating circuits requiring no adjustment can be designed by utilizing these resonators in conjunction with transistors or appropriate ICs.

■ Applications

1. Square-wave and sine-wave oscillators
2. Clock generator for microprocessors
3. Remote control systems

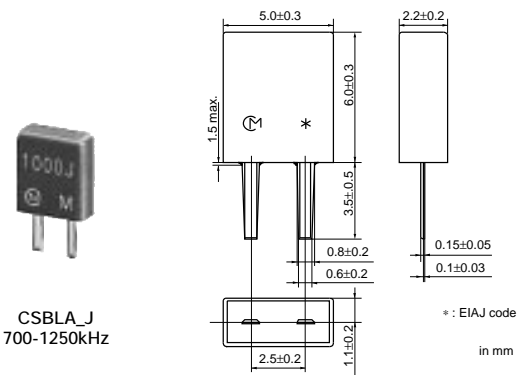
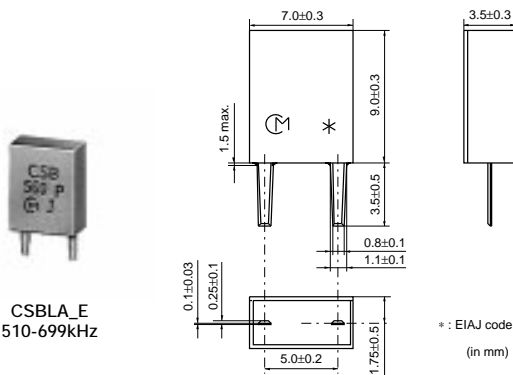
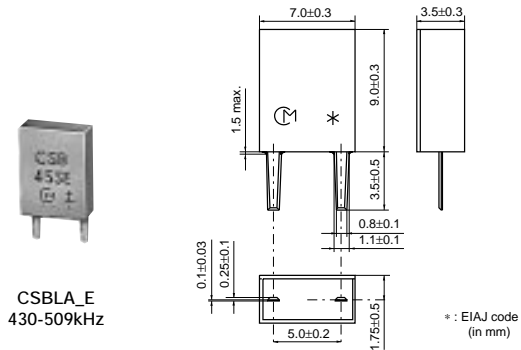
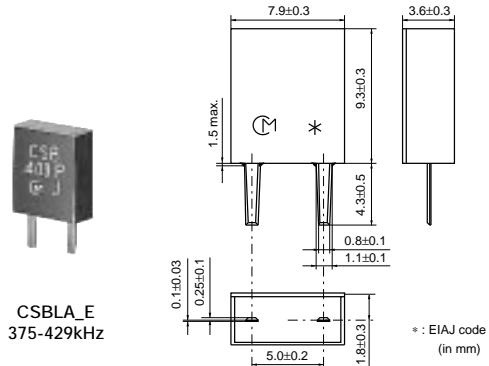

Part Number	Oscillating Frequency (kHz)	Initial Tolerance	Temp. Stability (%)	Temperature Range (°C)
CSBLA_E	375 to 699	-	±0.3	-20 to +80
CSBLA_J	700 to 1250	±0.5%	±0.3	-20 to 80

Irregular or stop oscillation may occur under unmatched circuit conditions. Please check the actual conditions prior to use.
 The order quantity should be an integral multiple of the "Minimum Quantity" shown in the packaging page.

■ Oscillation Frequency Measuring Circuit

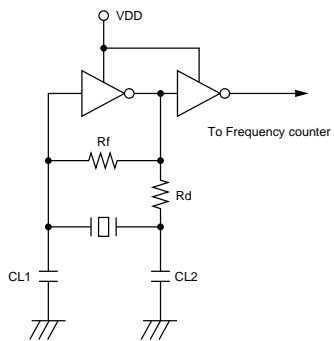

■ Oscillation Frequency Temperature Stability

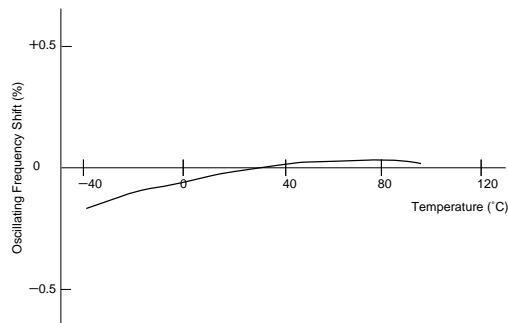

MHz Chip Type Notice (Soldering and Mounting) for General Usage

■ CSTCC Series

1. Soldering Conditions

(1) Reflow

One heat stress, shown in the profile at right, is applied to resonator; then, after being placed in natural conditions for 1 hour, the resonator is measured.

- (a) Pre-heating conditions should be +150 to +180°C for 60 to 120 seconds. Ascending time up to +150°C should be longer than 30 seconds.
- (b) Heating conditions should be within 40 seconds at +230°C min., but peak temperature should be lower than +260°C.

(2) Soldering Iron

Components shall be measured after soldering on PCB at +350±5°C for 3.0±0.5 seconds and leaving in natural condition for 24 hours. The soldering iron shall not touch the components while soldering.

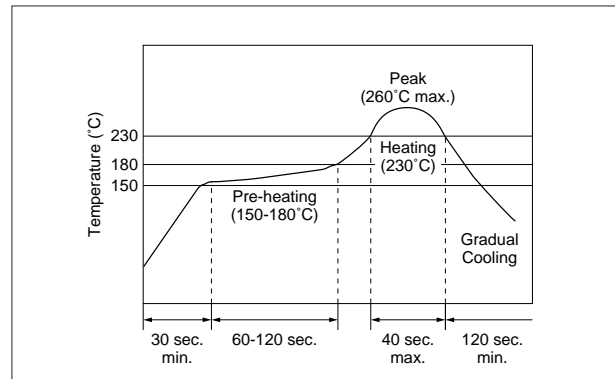

2. Wash

Some series do not withstand washing.
Please check the list at right before use.

Series	Wash
CSTCC (Except 2.00 - 3.49MHz)	Available
CSTCC (Only 2.00 - 3.49MHz)	Not Available

(1) Cleaning Solvents

HCFC, Isopropanol, Tap water, Demineralized water, Cleanthrough750H, Pine alpha 100S, Techno care FRW

(2) Temperature Difference : dT *1

$dT \leq 60^\circ\text{C}$ ($dT = \text{Component} - \text{solvent}$)

*1 ex. In case the component at +90°C immerses into cleaning solvent at +60°C, then $dT = 30^\circ\text{C}$.

(3) Conditions

(a) Ultrasonic Wash

1 minute max. in above solvent at +60°C max.
(Frequency: 28kHz, Output: 20W/l)

(b) Immersion Wash

5 minutes max. in above solvent at +60°C max.

(c) Shower or Rinse Wash

5 minutes max. in above solvent at +60°C max.

(4) Drying

5 minutes max. by air blow at +80°C max.

(5) Others

- (a) Total washing time should be within 10 minutes.
- (b) The component may be damaged if it is washed with chlorine, petroleum, or alkali cleaning solvent.

3. Notice for Mounting

- (a) The component is recommended for use with placement machines which employ optical placement capabilities. The component might be damaged by excessive mechanical force. Please make sure to evaluate by using placement machines before going into mass production. Do not use placement machines which utilize mechanical positioning. Please contact Murata for details beforehand.

- (b) Please insure the component is thoroughly evaluated in your application circuit.
- (c) Please do not apply excess mechanical stress to the component and terminals during soldering.

MHz Chip Type Notice (Soldering and Mounting) for General Usage

■ CSTCR/CSTCE_V/CSTCG/CSTCE_G/CSTCE_XK Series

1. Soldering Conditions

(1) Reflow

One heat stress, shown in the profile at right, is applied to resonator; then, after being placed in natural conditions for 1 hour, the resonator is measured.

(a) Pre-heating conditions should be +150 to +180°C for 60 to 120 seconds. Ascending time up to +150°C should be longer than 30 seconds.

(b) Heating conditions should be within 40 seconds at +230°C min., but peak temperature should be lower than +260°C.

(2) Soldering Iron

Components shall be measured after soldering on PCB at +350±5°C for 3.0±0.5 seconds and leaving in natural condition for 24 hours. The soldering iron shall not touch the components while soldering.

2. Wash

Please contact us in case you need washable component.

3. Notice for Mounting

(a) The component is recommended for use with placement machines which employ optical placement capabilities. The component might be damaged by excessive mechanical force. Please make sure to evaluate by using placement machines before going into mass production. Do not use placement machines which utilize mechanical positioning. Please contact Murata for details beforehand.

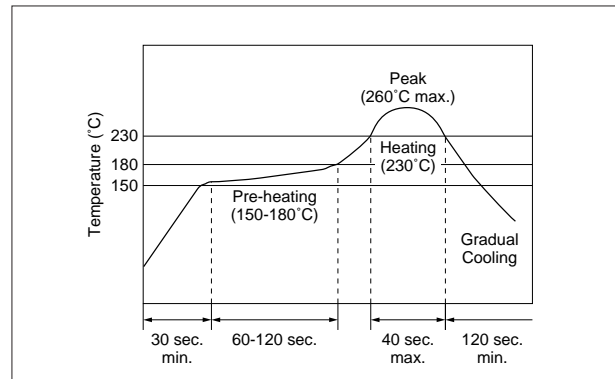

(b) Please insure the component is thoroughly evaluated in your application circuit.

(c) Please do not apply excess mechanical stress to the component and terminals during soldering.

MHz Chip Type Notice (Soldering and Mounting) for General Usage

■ CSTCV/CSACV Series

1. Soldering Conditions

(1) Reflow

One heat stress, shown in the profile at right, is applied to resonator; then, after being placed in natural conditions for 1 hour, the resonator is measured.

(a) Pre-heating conditions should be +150 to +180°C for 60 to 120 seconds. Ascending time up to +150°C should be longer than 30 seconds.

(b) Heating conditions should be within 40 seconds at +230°C min., but peak temperature should be lower than +260°C.

(2) Soldering Iron

Components shall be measured after soldering on PCB at +350±5°C for 3.0±0.5 seconds and leaving in natural condition for 24 hours. The soldering iron shall not touch the components while soldering.

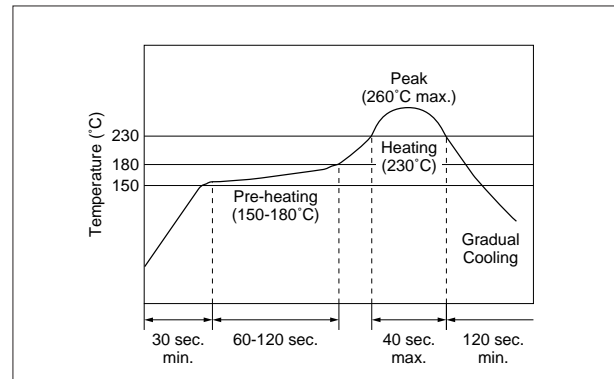

2. Wash

(1) Cleaning Solvents

HCFC, Isopropanol, Tap water, Demineralized water, Cleanthrough750H, Pine alpha 100S, Techno care FRW

(2) Temperature Difference : dT *1

$dT \leq 60^\circ\text{C}$ ($dT = \text{Component} - \text{solvent}$)

*1 ex. In case the component at +90°C immerses into cleaning solvent at +60°C, then $dT = 30^\circ\text{C}$.

(3) Conditions

(a) Ultrasonic Wash

1 minute max. in above solvent at +60°C max.
(Frequency: 28kHz, Output: 20W/l)

(b) Immersion Wash

5 minutes max. in above solvent at +60°C max.

(c) Shower or Rinse Wash

5 minutes max. in above solvent at +60°C max.

(4) Drying

5 minutes max. by air blow at +80°C max.

(5) Others

(a) Total washing time should be within 10 minutes.

(b) The component may be damaged if it is washed with chlorine, petroleum, or alkali cleaning solvent.

3. Notice for Mounting

(a) The component is recommended for use with placement machines which employ optical placement capabilities. In some cases, placement machines which utilize mechanical positioning may apply excessive mechanical force which might result in damage to the ceramic resonator. Please contact Murata before mounting this product using placement machines which use mechanical positioning.

(b) Please insure the component is thoroughly evaluated in your application circuit.

(c) Please do not apply excess mechanical stress to the component and terminals during soldering.

MHz Chip Type Notice (Soldering and Mounting) for General Usage

■ CSACW/CSTCW/CSTCZ Series

1. Soldering Conditions

(1) Reflow

One heat stress, shown in the profile at right, is applied to resonator; then, after being placed in natural conditions for 1 hour, the resonator is measured.

(a) Pre-heating conditions should be +150 to +180°C for 60 to 120 seconds. Ascending time up to +150°C should be longer than 30 seconds.

(b) Heating conditions should be within 40 seconds at +230°C min., but peak temperature should be lower than +260°C.

(2) Soldering Iron

Components shall be measured after soldering on PCB at +350±5°C for 3.0±0.5 seconds and leaving in natural condition for 24 hours. The soldering iron shall not touch the components while soldering.

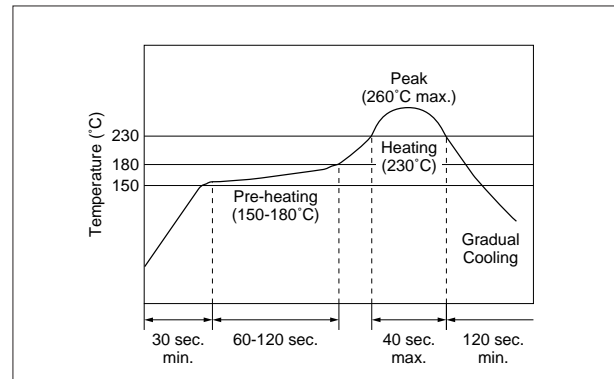

2. Wash

Please contact us in case you need washable component.

3. Notice for Mounting

(a) Please insure the component is thoroughly evaluated in your application circuit.

(b) Please do not apply excess mechanical stress to the component and terminals during soldering.

MHz Chip Type Notice for General Usage

■ Notice (Storage and Operating Conditions)

1. Product Storage Condition

Please store the products in room where the temperature/humidity is stable. And avoid such places where there are large temperature changes. Please store the products under the following conditions:

Temperature: -10 to + 40 degrees C

Humidity: 15 to 85% R.H.

2. Expire Date on Storage

Expire date (Shelf life) of the products is six months after delivery under the conditions of a sealed and an unopened package. Please use the products within six months after delivery. If you store the products for a long time (more than six months), use carefully because the products may be degraded in the solderability and/or rusty. Please confirm solderability and characteristics for the products regularly.

3. Notice on Product Storage

- (1) Please do not store the products in a chemical atmosphere (Acids, Alkali, Bases, Organic gas, Sulfides and so on), because the characteristics may be reduced in quality, and/or be degraded in the solderability due to the storage in a chemical atmosphere.

- (2) Please do not put the products directly on the floor without anything under them to avoid damp places and/or dusty places.

- (3) Please do not store the products in the places such as: in a damp heated place, in a place where direct sunlight comes in, in place applying vibrations.

- (4) Please use the products immediately after the package is opened, because the characteristics may be reduced in quality, and/or be degraded in the solderability due to storage under the poor condition.

- (5) Please do not drop the products to avoid cracking of ceramic element.

4. Others

Conformal coating or washing of the component is not acceptable because it is not hermetically sealed. Please be sure to consult with our sales representative or engineer whenever and prior to using the products.

■ Notice (Rating)

The component may be damaged if excess mechanical stress is applied.

■ Notice (Handling)

"CERALOCK" may stop oscillating or oscillate irregularly under improper circuit conditions.

MHz Lead Type Notice for General Usage

■ Notice (Soldering and Mounting)

1. Soldering Conditions

(1) Reflow

The component cannot withstand reflow soldering.

(2) Soldering Iron

(a) Lead terminals are immersed up to 1.5 mm from components body in soldering bath of +260+-5 degrees C for 10+-1.0 seconds, and then components shall be left in natural condition for 1 hour.

(b) Lead terminal is directly contacted with the tip of soldering iron of +350+-5 degrees C

for 3.0+-0.5 seconds, and then components shall be left in natural condition for 1 hour.

(3) Please do not apply excessive mechanical stress to the component and lead terminals during soldering.

2. Wash

The component cannot withstand washing.

■ Notice (Storage and Operating Conditions)

1. Product Storage Condition

Please store the products in room where the temperature/humidity is stable. And avoid such places where there are large temperature changes. Please store the products under the following conditions:

Temperature: -10 to + 40 degrees C

Humidity: 15 to 85% R.H.

2. Expire Date on Storage

Expire date (Shelf life) of the products is six months after delivery under the conditions of a sealed and an unopened package. Please use the products within six months after delivery. If you store the products for a long time (more than six months), use carefully because the products may be degraded in the solderability and/or rusty. Please confirm solderability and characteristics for the products regularly.

3. Notice on Product Storage

(1) Please do not store the products in a chemical atmosphere (Acids, Alkali, Bases, Organic gas, Sulfides and so on), because the characteristics may be reduced in quality, and/or be degraded in the solderability due to the storage in a chemical atmosphere.

(2) Please do not put the products directly on the floor without anything under them to avoid damp places and/or dusty places.

(3) Please do not store the products in the places such as: in a damp heated place, in a place where direct sunlight comes in, in place applying vibrations.

(4) Please use the products immediately after the package is opened, because the characteristics may be reduced in quality, and/or be degraded in the solderability due to storage under the poor condition.

(5) Please do not drop the products to avoid cracking of ceramic element.

4. Others

Conformal coating or washing of the component is not acceptable because it is not hermetically sealed. Please be sure to consult with our sales representative or engineer whenever and prior to using the products.

■ Notice (Rating)

The component may be damaged if excess mechanical stress is applied.

■ Notice (Handling)

"CERALOCK" may stop oscillating or oscillate irregularly under improper circuit conditions.

kHz Type Notice for General Usage

■ Notice (Soldering and Mounting)

CSBFB_J (430-519kHz/700-1250kHz)

1. Soldering Conditions

(1) Reflow

One heat stress, shown in the profile at right, is applied to resonator; then, after being placed in natural conditions for 1 hour, the resonator is measured.

- (a) Pre-heating conditions should be +150 to +180°C for 60 to 120 seconds. Ascending time up +150°C should be longer than 30 seconds.
- (b) Heating conditions should be within 40 seconds at +230°C min., but peak temperature should be lower than +260°C.

(2) Soldering Iron

Components shall be measured after soldering on PCB at +350±5°C for 3.0±0.5 seconds and leaving in natural condition for 24 hours. The soldering iron shall not touch the components while soldering.

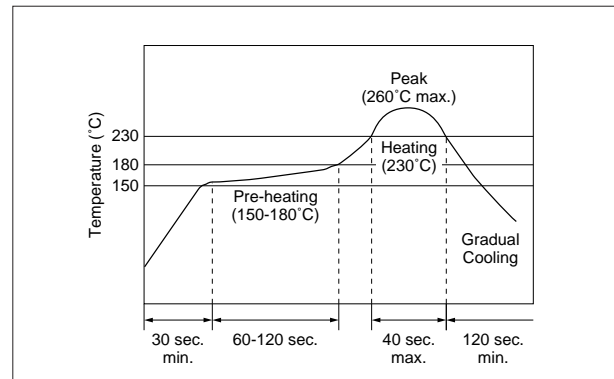

2. Wash

(1) Cleaning Solvents

HCFC, Isopropanol, Tap water, Demineralized water, Cleanthrough750H, Pine alpha 100S, Techno care FRW

(2) Temperature Difference : dT *1

$dT \leq 60^\circ\text{C}$ ($dT = \text{Component} - \text{solvent}$)

*1 ex. In case the component at +90°C immerses into cleaning solvent at +60°C, then $dT = 30^\circ\text{C}$.

(3) Conditions

(a) Ultrasonic Wash

1 minute max. in above solvent at +60°C max.
(Frequency: 28kHz, Output: 20W/l)

(b) Immersion Wash

5 minutes max. in above solvent at +60°C max.

(c) Shower or Rinse Wash

5 minutes max. in above solvent at +60°C max.

(4) Drying

5 minutes max. by air blow at +80°C max.

(5) Others

- (a) Total washing time should be within 10 minutes.
- (b) The component may be damaged if it is washed with chlorine, petroleum, or alkali cleaning solvent.

(c) Ultrasonic cleaning of the component is acceptable. However, the size of bath, size and thickness of PCB should be evaluated to confirm stable electrical characteristics are maintained.

3. Notice for Mounting

- (a) Please insure the component is thoroughly evaluated in your application circuit.
- (b) Please do not apply excess mechanical stress to the component and lead terminals during soldering.

(c) In the case of the bulk component, dry heating treatment (130°C. for 5 hours min.) is required before reflow soldering. Then, the component should be soldered within 48 hours after dry heating treatment.

kHz Type Notice for General Usage

■ Notice (Soldering and Mounting)

CSBLA_E

1. Soldering Conditions

(1) Reflow

The component cannot withstand reflow soldering.

(2) Soldering Iron

(a) Lead terminals are immersed up to 1.5 mm from components body in soldering bath of +260+-5 degrees C for 10+-1.0 seconds, and then components shall be left in natural condition for 1 hour.

(b) Lead terminal is directly contacted with the tip of soldering iron of +350+-5 degrees C

for 3.0+-0.5 seconds, and then components shall be left in natural condition for 1 hour.

(3) Please do not apply excessive mechanical stress to the component and lead terminals during soldering.

2. Wash

The component cannot withstand washing.

■ Notice (Soldering and Mounting)

CSBLA_J

(1) Cleaning Solvents

HCFC, Isopropanol, Tap water, Demineralized water, Cleanthrough750H, Pine alpha 100S, Techno care FRW.

(2) Temperature Difference: dT *1

dT<=30 C. (dT=Component-solvent)

*1 ex. In case the component at +90 degrees C. immerses into cleaning solvent at +60 degrees C., then dT=30 degrees C.

(3) Conditions

1. Ultrasonic Wash

1 minute max. in above solvent at +60 degrees C. max. (Frequency: 28kHz, Output: 20W/L)

2. Immersion Wash

5 minutes max. in above solvent at +60 degrees C. max.

3. Shower or Rinse Wash

5 minutes max. in above solvent at +60 degrees C. max.

(4) Drying

5 minutes max. by air blow at +80 degrees C. max.

(5) Others

1. Total washing time should be within 10 minutes.

2. Please insure the component is thoroughly evaluated in your application circuit.

3. The component may be damaged if it is washed with alkali cleaning solvent.

4. Please do not apply excess mechanical stress to the component and lead terminals during soldering.

5. Ultrasonic cleaning of the component is acceptable. However, the size of bath, size and thickness of PBC should be evaluated to confirm stable electrical characteristics are maintained.

■ Notice (Storage and Operating Condition)

CSBFB_J/CSBLA_J

1. Product Storage Condition

Please store the products in room where the temperature/humidity is stable. And avoid such places where there are large temperature changes. Please store the products under the following conditions:

Temperature: -10 to + 40 degrees C

Humidity: 15 to 85% R.H.

2. Expire Date on Storage

Expire date (Shelf life) of the products is six months after delivery under the conditions of a sealed and an unopened package. Please use the products within six months after delivery. If you store the products for a long time (more than six months), use carefully because the products may be degraded in the solderability and/or rusty. Please confirm solderability and characteristics for the products regularly.

3. Notice on Product Storage

(1) Please do not store the products in a chemical atmosphere (Acids, Alkali, Bases, Organic gas, Sulfides and so on), because the characteristics may be reduced in quality, and/or be degraded in the solderability due to the storage in a chemical atmosphere.

(2) Please do not put the products directly on the floor without anything under them to avoid damp places and/or dusty places.

(3) Please do not store the products in the places such as: in a damp heated place, in a place where direct sunlight comes in, in place applying vibrations.

(4) Please use the products immediately after the package is opened, because the characteristics may be reduced in quality, and/or be degraded in the solderability due to storage under the poor condition.

(5) Please do not drop the products to avoid cracking of ceramic element.

Continued on the following page. 

kHz Type Notice for General Usage

☒ Continued from the preceding page.

4. Others

Conformal coating of the component is acceptable. However, the resin material, curing temperature, and other process conditions should be evaluated to confirm that stable electrical characteristics are maintained.

Please be sure to consult with our sales representative or engineer whenever and prior to using the products.

■ Notice (Storage and Operating Condition)

CSBLA_E

1. Product Storage Condition

Please store the products in room where the temperature/humidity is stable. And avoid such places where there are large temperature changes. Please store the products under the following conditions:

Temperature: -10 to + 40 degrees C

Humidity: 15 to 85% R.H.

2. Expire Date on Storage

Expire date (Shelf life) of the products is six months after delivery under the conditions of a sealed and an unopened package. Please use the products within six months after delivery. If you store the products for a long time (more than six months), use carefully because the products may be degraded in the solderability and/or rusty. Please confirm solderability and characteristics for the products regularly.

3. Notice on Product Storage

(1) Please do not store the products in a chemical atmosphere (Acids, Alkali, Bases, Organic gas, Sulfides and so on), because the characteristics may be reduced in quality, and/or be degraded in the solderability due to the storage in a chemical atmosphere.

(2) Please do not put the products directly on the floor without anything under them to avoid damp places and/or dusty places.

(3) Please do not store the products in the places such as: in a damp heated place, in a place where direct sunlight comes in, in place applying vibrations.

(4) Please use the products immediately after the package is opened, because the characteristics may be reduced in quality, and/or be degraded in the solderability due to storage under the poor condition.

(5) Please do not drop the products to avoid cracking of ceramic element.

4. Others

Conformal coating or washing of the component is not acceptable because it is not hermetically sealed. Please be sure to consult with our sales representative or engineer whenever and prior to using the products.

■ Notice (Rating)

The component may be damaged if excess mechanical stress is applied.

■ Notice (Handling)

"CERALOCK" may stop oscillating or oscillate irregularly under improper circuit conditions.

MHz Chip Type Packaging for General Usage

Minimum Quantity

Part Number	Plastic Tape ø180mm	Plastic Tape ø330mm	Bulk	Dimensions
CSTCC_G	2,000	6,000	500	a
CSTCR_G	3,000	9,000	500	a
CSTCR_G15L	3,000	9,000	500	a
CSTCE_G	3,000	9,000	500	b
CSTCE_G15L	3,000	9,000	500	b
CSTCE_V	3,000	9,000	500	b
CSTCE_V13L	3,000	9,000	500	b
CSTCE_XK	3,000	9,000	500	b
CSTCE_XT	3,000	9,000	500	b
CSTCG_V	3,000	9,000	500	b
CSTCZ_X12R	3,000	9,000	500	b
CSTCW_X	3,000	9,000	500	b
CSTCW_X11	3,000	9,000	500	b
CSTCW_X_M	3,000	9,000	500	b
CSACW_X	3,000	9,000	500	b

The order quantity should be an integral multiple of the "Minimum Quantity" shown above.

(pcs.)

Dimensions of Reel

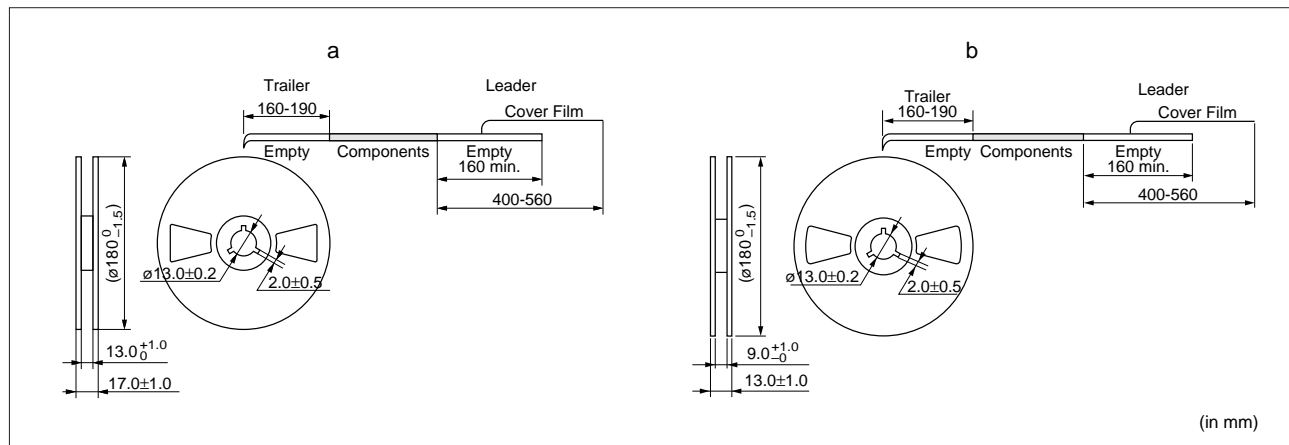

(in mm)

Dimensions of Taping

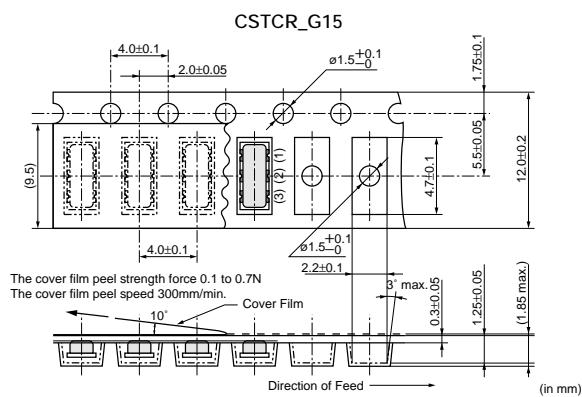

(in mm)

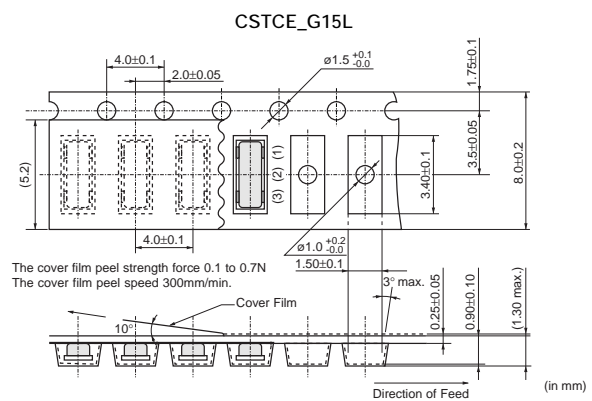

(in mm)

Continued on the following page. ↗

MHz Chip Type Packaging for General Usage

Continued from the preceding page.

Dimensions of Taping

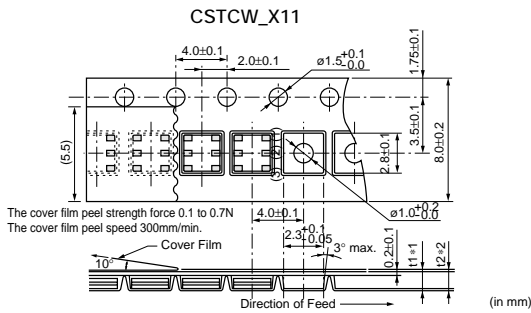
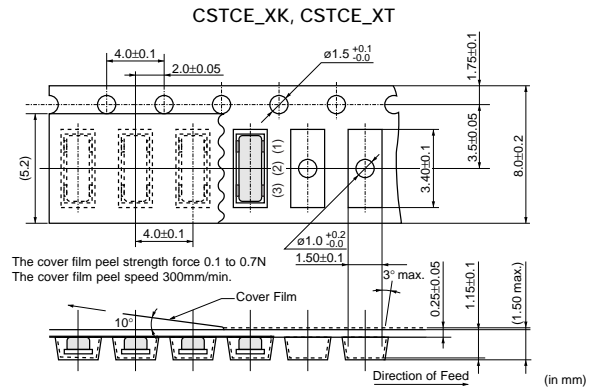
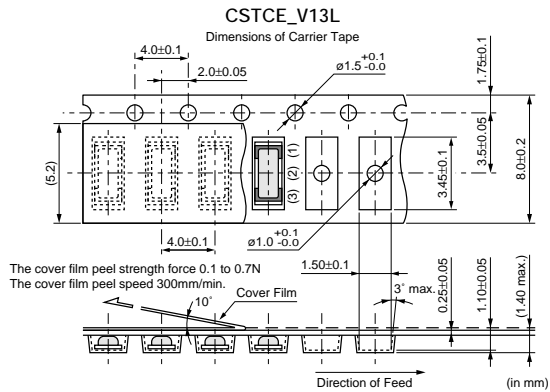

*1, *2 : Dimensions vary with product thickness of CERALOCK®

Thickness of CERALOCK®	1.40-1.20	1.15-1.00	0.95-0.90	
t1	*1	1.48±0.1	1.30±0.1	1.12±0.1
t2	*2	2.1 max.	1.9 max.	1.7 max.

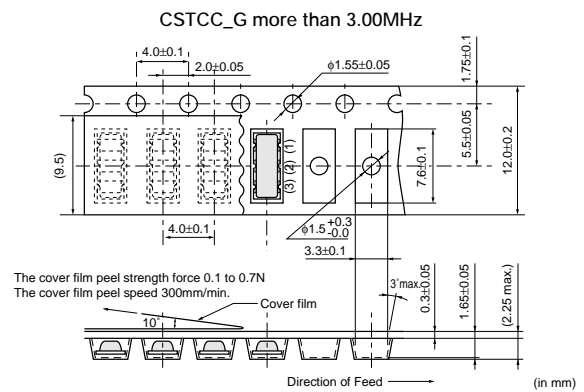
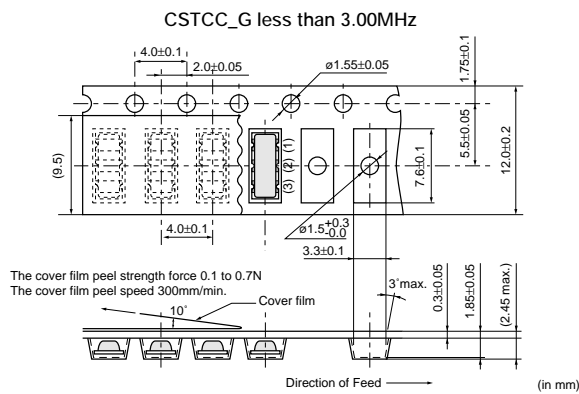
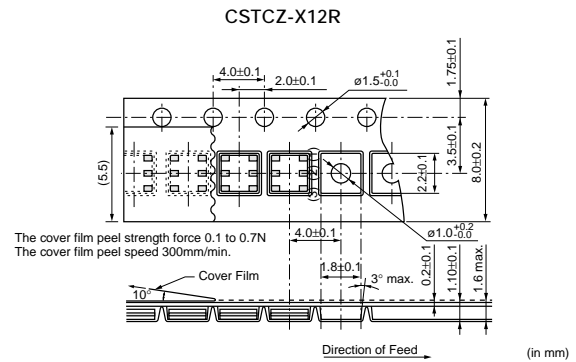

Continued on the following page. ↗

MHz Chip Type Packaging for General Usage

Continued from the preceding page.

■ Dimensions of Taping

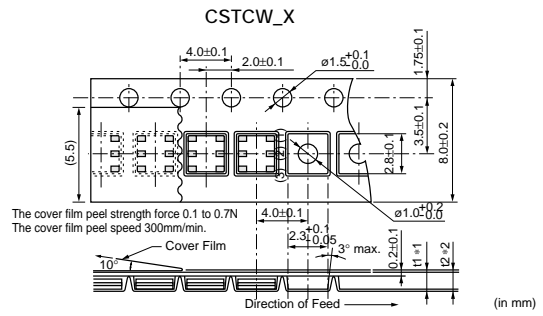
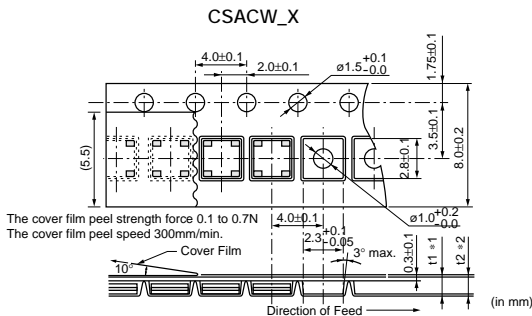
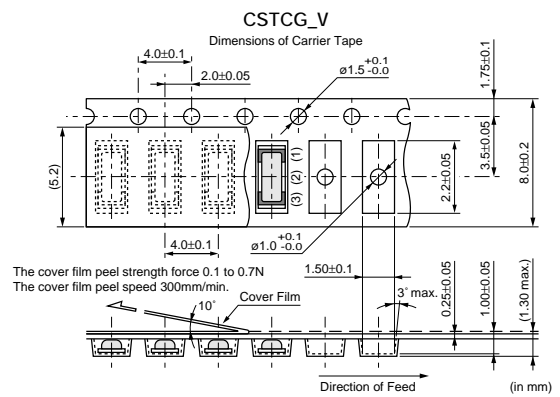
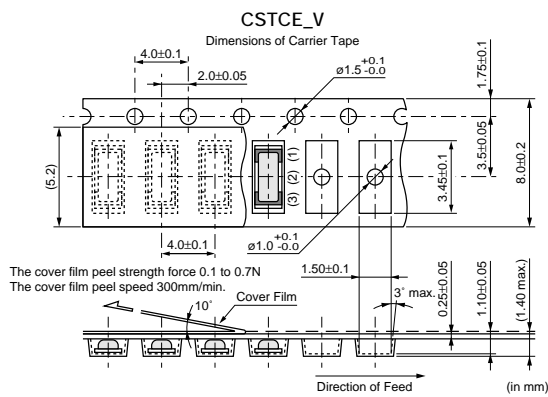
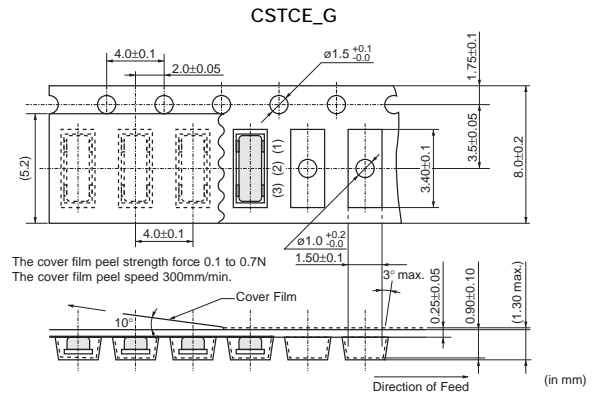
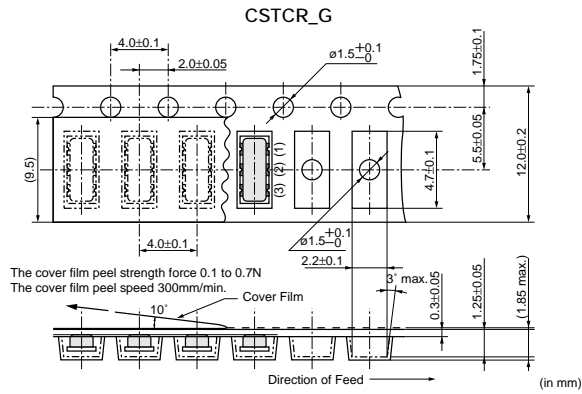

*1, *2 : Dimensions vary with product thickness of CERALOCK®

Thickness of CERALOCK®	1.40-1.20	1.15-1.00	0.95-0.90	
t1	*1	1.48±0.1	1.30±0.1	1.12±0.1
t2	*2	2.1 max.	1.9 max.	1.7 max.

*1, *2 : Dimensions vary with product thickness of CERALOCK®

Thickness of CERALOCK®	1.40-1.20	1.15-1.00	0.95-0.90	
t1	*1	1.48±0.1	1.30±0.1	1.12±0.1
t2	*2	2.1 max.	1.9 max.	1.7 max.

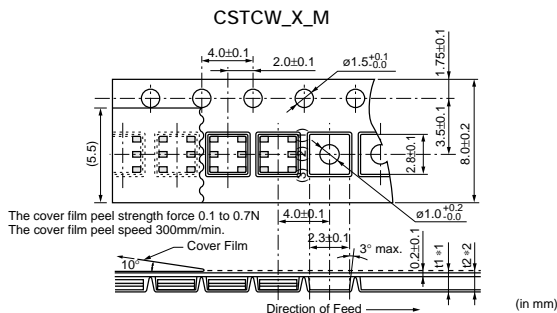

*1, *2 : Dimensions vary with product thickness of CERALOCK®

Thickness of CERALOCK®	1.40-1.20	1.15-1.00	0.95-0.70	
t1	*1	1.48±0.1	1.30±0.1	1.12±0.1
t2	*2	2.1 max.	1.9 max.	1.7 max.

MHz Lead Type Packaging for General Usage

Minimum Quantity

Part Number	Ammo Pack	Bulk
CSTLS_G (3.40 to 10.0MHz)	2,000	500
CSTLS_X (16.00 to 70.00MHz)	2,000	500

The order quantity should be an integral multiple of the "Minimum Quantity" shown above.

(pcs.)

Tape Dimensions of CSTLS_G

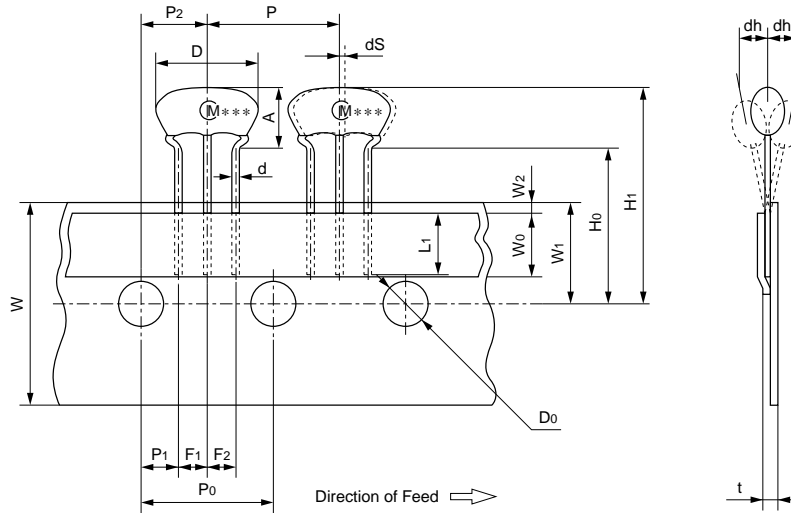

Item	Code	Dimensions	Tolerance	Remarks
Width of diameter	D	8.0	±1.0	
Height of resonator	A	5.5	±0.5	
Dimensions of terminal	d	ø0.48	±0.05	
Lead length under the hold down tape	L1	5.0 min.	—	
Pitch of component	P	12.7	±0.5	Tolerance for Pitches 10xP0=127±1
Pitch of sprocket hole	P0	12.7	±0.2	
Length from sprocket hole center to lead	P1	3.85	±0.5	
Length from sprocket hole center to component center	P2	6.35	±0.5	
Lead spacing (I)	F1	2.5	±0.2	
Lead spacing (II)	F2	2.5	±0.2	
Slant forward or backward	dh	0	±1.0	1mm max.
Width of carrier tape	W	18.0	±0.5	
Width of hold down tape	W0	6.0 min.	—	Hold down tape does not exceed the carrier tape.
Position of sprocket hole	W1	9.0	±0.5	
Gap of hold down tape and carrier tape	W2	0	+0.5 -0	
Distance between the center of sprocket hole and lead stopper	H0	18.0	±0.5	
Total height of resonator	H1	23.5	±1.0	
Diameter of sprocket hole	D0	ø4.0	±0.2	
Total tape thickness	t	0.6	±0.2	
Body tilt	dS	0	±1.0	

(in mm)

Continued on the following page.

MHz Lead Type Packaging for General Usage

Continued from the preceding page.

■ Tape Dimensions of CSTLS_X

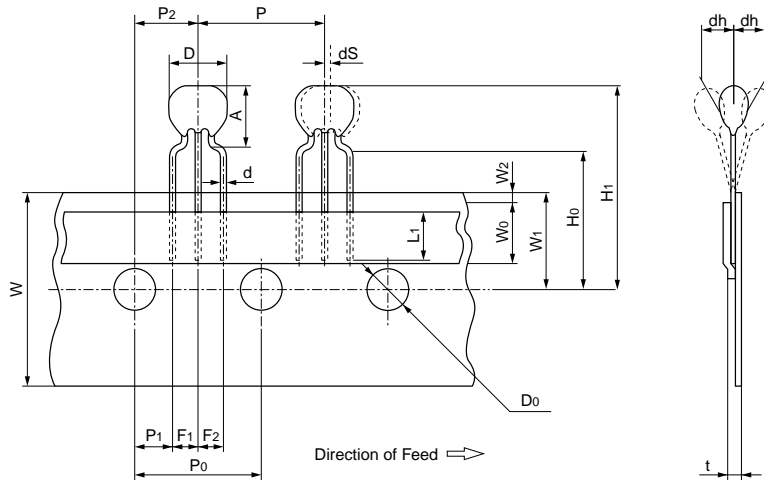

Item	Code	Dimensions	Tolerance	Remarks
Width of diameter	D	5.5	±1.0	
Height of resonator	A	6.5	±0.5	
Dimensions of terminal	d	ø0.48	±0.05	
Lead length under the hold down tape	L1	5.0 min.	—	
Pitch of component	P	12.7	±0.5	Tolerance for Pitches 10xP0=127±1
Pitch of sprocket hole	P0	12.7	±0.2	
Length from sprocket hole center to lead	P1	3.85	±0.5	
Length from sprocket hole center to component center	P2	6.35	±0.5	
Lead spacing (I)	F1	2.5	±0.2	
Lead spacing (II)	F2	2.5	±0.2	
Slant forward or backward	dh	0	±1.0	1mm max.
Width of carrier tape	W	18.0	±0.5	
Width of hold down tape	W0	6.0 min.	—	Hold down tape does not exceed the carrier tape.
Position of sprocket hole	W1	9.0	±0.5	
Gap of hold down tape and carrier tape	W2	0	+0.5 -0.0	
Distance between the center of sprocket hole and lead stopper	H0	18.0	±0.5	
Total height of resonator	H1	24.5	±1.0	
Diameter of sprocket hole	D0	ø4.0	±0.2	
Total tape thickness	t	0.6	±0.2	
Body tilt	dS	0	±1.0	

(in mm)

MHz Lead Type Packaging for General Usage

Minimum Quantity

Part Number	Ammo Pack	Bulk
CSALS_X (16.00 to 70.00MHz)	2,000	500

The order quantity should be an integral multiple of the "Minimum Quantity" shown above.

(pcs.)

Tape Dimensions of CSALS

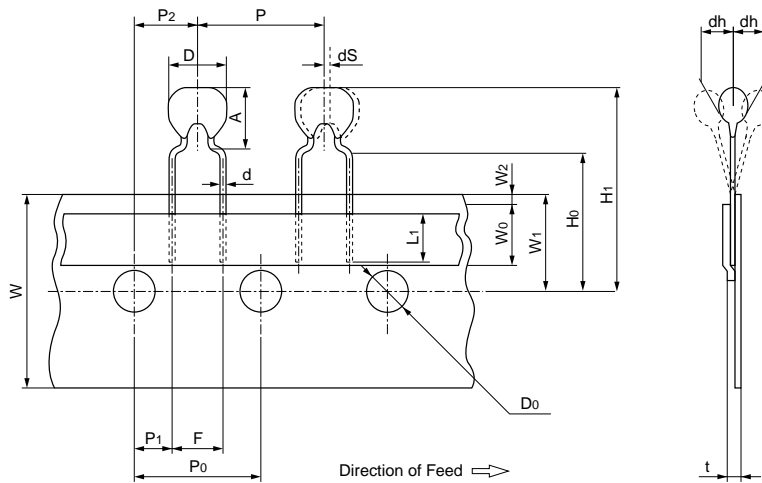

Item	Code	Dimensions	Tolerance	Remarks
Width of diameter	D	5.5	±1.0	
Height of resonator	A	6.5	±0.5	
Dimensions of terminal	d	ø0.48	±0.05	
Lead length under the hold down tape	L1	5.0 min.	—	
Pitch of component	P	12.7	±0.5	Tolerance for Pitches 10xP0=127±1
Pitch of sprocket hole	P0	12.7	±0.2	
Length from sprocket hole center to lead	P1	3.85	±0.5	
Length from sprocket hole center to component center	P2	6.35	±0.5	
Lead spacing	F	5.0	±0.3	
Slant forward or backward	dh	0	±1.0	1mm max.
Width of carrier tape	W	18.0	±0.5	
Width of hold down tape	W0	6.0 min.	—	Hold down tape does not exceed the carrier tape.
Position of sprocket hole	W1	9.0	±0.5	
Gap of hold down tape and carrier tape	W2	0	+0.5 -0	
Distance between the center of sprocket hole and lead stopper	H0	18.0	±0.5	
Total height of resonator	H1	24.5	±1.0	
Diameter of sprocket hole	D0	ø4.0	±0.2	
Total tape thickness	t	0.6	±0.2	
Body tilt	dS	0	±1.0	

(in mm)

kHz Type Packaging for General Usage

■ CSBFB Series Minimum Quantity

Part Number	Plastic Tape ø330mm	Bulk
CSBFB_J (430 to 519kHz)	1,500	500
CSBFB_J (700 to 1250kHz)	3,000	1,000

The order quantity should be an integral multiple of the "Minimum Quantity" shown above.

(pcs.)

■ Dimensions of Reel

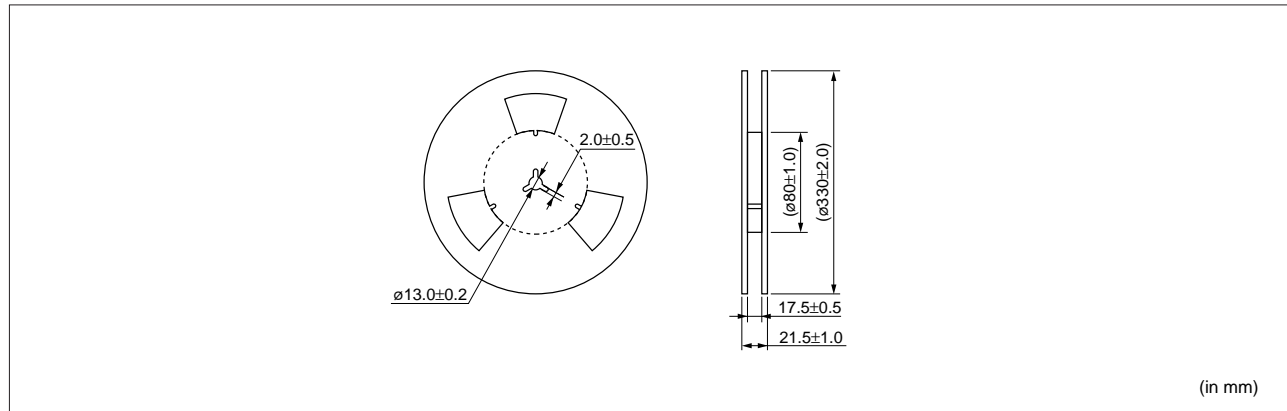

■ Dimensions of Taping

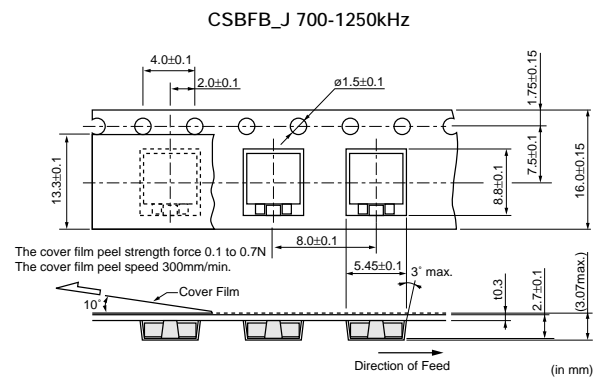
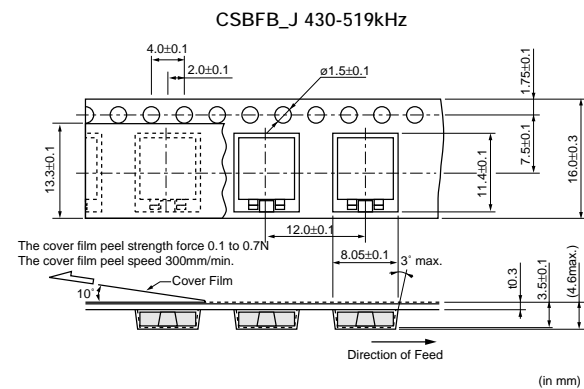

■ CSBLA Series Minimum Quantity

Part Number	Magazine	Bulk
CSBLA_E	50	500
CSBLA_J	100	1,000

The order quantity should be an integral multiple of the "Minimum Quantity" shown above.

(pcs.)

△Note:

1. Export Control

<For customers outside Japan>

No muRata products should be used or sold, through any channels, for use in the design, development, production, utilization, maintenance or operation of, or otherwise contribution to (1) any weapons (Weapons of Mass Destruction [nuclear, chemical or biological weapons or missiles] or conventional weapons) or (2) goods or systems specially designed or intended for military end-use or utilization by military end-users.

<For customers in Japan>

For products which are controlled items subject to the "Foreign Exchange and Foreign Trade Law" of Japan, the export license specified by the law is required for export.

2. Please contact our sales representatives or product engineers before using the products in this catalog for the applications listed below, which require especially high reliability for the prevention of defects which might directly damage a third party's life, body or property, or when one of our products is intended for use in applications other than those specified in this catalog.

- | | |
|-----------------------------|--|
| ① Aircraft equipment | ② Aerospace equipment |
| ③ Undersea equipment | ④ Power plant equipment |
| ⑤ Medical equipment | ⑥ Transportation equipment (vehicles, trains, ships, etc.) |
| ⑦ Traffic signal equipment | ⑧ Disaster prevention / crime prevention equipment |
| ⑨ Data-processing equipment | ⑩ Application of similar complexity and/or reliability requirements to the applications listed above |

3. Product specifications in this catalog are as of September 2007. They are subject to change or our products in it may be discontinued without advance notice. Please check with our sales representatives or product engineers before ordering. If there are any questions, please contact our sales representatives or product engineers.

4. Please read rating and △ CAUTION (for storage, operating, rating, soldering, mounting and handling) in this catalog to prevent smoking and/or burning, etc.

5. This catalog has only typical specifications because there is no space for detailed specifications. Therefore, please approve our product specifications or transact the approval sheet for product specifications before ordering.

6. Please note that unless otherwise specified, we shall assume no responsibility whatsoever for any conflict or dispute that may occur in connection with the effect of our and/or a third party's intellectual property rights and other related rights in consideration of your use of our products and/or information described or contained in our catalogs. In this connection, no representation shall be made to the effect that any third parties are authorized to use the rights mentioned above under licenses without our consent.

7. No ozone depleting substances (ODS) under the Montreal Protocol are used in our manufacturing process.



<http://www.murata.com/>

Head Office
1-10-1, Higashi Kotari, Nagaokakyo-shi, Kyoto 617-8555, Japan
Phone: 81-75-951-9111

International Division
3-29-12, Shibuya, Shibuya-ku, Tokyo 150-0002, Japan
Phone: 81-3-5469-6123 Fax: 81-3-5469-6155 E-mail: intl@murata.co.jp