

# IQXO-35, -36 Industrial Oscillator

ISSUE 5; 19 OCTOBER 1999

## Delivery Options

- Please contact our sales office for current leadtimes

## Output Compatibility

- HCMOS/TTL
- Drive Capability: 50pF or 10TTL
- Non tri-state (IQXO-35)
- Tri-state (IQXO-36)

## Package Outline

- 8-pin DIL compatible resistance welded enclosure, hermetically sealed with glass to metal seals and high environmental performance

## Standard Frequency Stabilities

- $\pm 25\text{ppm}$ ,  $\pm 50\text{ppm}$ ,  $\pm 100\text{ppm}$   
(over operating temperature range)

## Frequency Tolerance @ 25°C (Optional)

- $\pm 5\text{ppm}$ ,  $\pm 10\text{ppm}$ ,  $\pm 25\text{ppm}$

## Operating Temperature Range

- -40 to 85°C

## Storage Temperature Range

- -55 to 125°C

## Environmental Specification

- Acceleration: 490m/s<sup>2</sup> for 1 minute in the 'Y<sub>1</sub>' plane
- Bump: 4000 bumps at 390m/s<sup>2</sup> in each of the three mutually perpendicular planes
- Hermetic Seal: not to exceed  $1 \times 10^{-8}$  mBar litres of Helium leakage
- Humidity: steady state: in accordance with test Ca of IEC 60068-2-3, for 56 days at 40°C at a relative humidity of 93%, cyclic: in accordance with test Db variant of IEC 60068-2-30, at severity b), 55°C for six cycles
- Shock: 981m/s<sup>2</sup> for 6ms, three shocks in each direction along the three mutually perpendicular planes
- Solderability: BS2011 test TA
- Rapid Change of Temperature over Operating Temperature Range: 10 cycles.
- Vibration: 10 to 60Hz 0.75mm displacement, 60 to 2000Hz 98.1m/s<sup>2</sup> acceleration, 30 minutes in each of three mutually perpendicular planes

## Tri-state Operation (IQXO-36)

- Logic '0' to pin 1 disables oscillator output; when disabled the oscillator output goes to the high impedance state
- No connection or Logic '1' to pin enables oscillator output
- Maximum 'pull-down' resistance required to disable output = 20k $\Omega$
- Disable current 50 $\mu$ A typical

## Marking

- Model number
- Frequency Stability Code
- Frequency Tolerance Code (Optional)
- Frequency
- Date Code (Year/Week)

## Minimum Order Information Required

- Frequency + Model Number + Frequency Stability

## Outline in mm

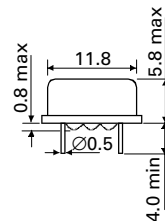

Pin connections  
 1. N/C or Enable/Disable.  
 4. GND  
 5. Output  
 8. +Vs

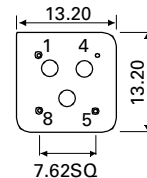

## Output Waveform - HCMOS/TTL

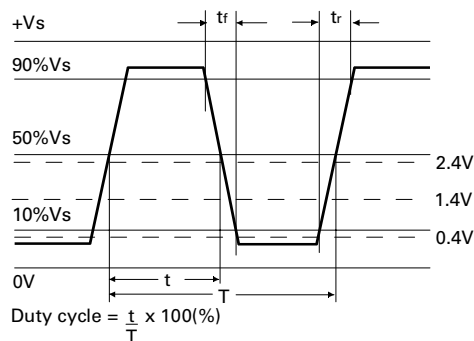

**Electrical Specifications - maximum limiting values when measured in HCMOS test circuit.**

Frequency Range	Frequency Stability	Supply Voltage	Supply Current	Rise Time( $t_r$ )	Fall Time( $t_f$ )	Duty Cycle	Model Number
500.0kHz to < 5.0MHz	$\pm 25\text{ppm}$ , $\pm 50\text{ppm}$ , $\pm 100\text{ppm}$	$5V \pm 0.25V$	20mA	15ns	15ns	45/55%	IQX0-35, -36
5.0 to < 16.0MHz	$\pm 25\text{ppm}$ , $\pm 50\text{ppm}$ , $\pm 100\text{ppm}$	$5V \pm 0.25V$	20mA	10ns	10ns	45/55%	IQX0-35, -36
16.0 to < 30.0MHz	$\pm 25\text{ppm}$ , $\pm 50\text{ppm}$ , $\pm 100\text{ppm}$	$5V \pm 0.25V$	30mA	10ns	10ns	45/55%	IQX0-35, -36
30.0 to < 50.0MHz	$\pm 25\text{ppm}$ , $\pm 50\text{ppm}$ , $\pm 100\text{ppm}$	$5V \pm 0.25V$	40mA	8ns	8ns	45/55%	IQX0-35, -36
50.0 to 70.0MHz	$\pm 25\text{ppm}$ , $\pm 50\text{ppm}$ , $\pm 100\text{ppm}$	$5V \pm 0.25V$	50mA	6ns	6ns	40/60%	IQX0-35, -36

**Ordering Example**

Frequency 22.0MHz      IQX0-35    B    F

Model number -35 = Non tri-state, -36 = Tri-state

Frequency Stability: A =  $\pm 25\text{ppm}$ , B =  $\pm 50\text{ppm}$ , C =  $\pm 100\text{ppm}$

Frequency Tolerance @ 25°C: D =  $\pm 5\text{ppm}$ ; E =  $\pm 10\text{ppm}$ ; F =  $\pm 25\text{ppm}$

Please note: Code combination A F is not available

LEADED SPX0s

**Test Circuit - HCMOS**

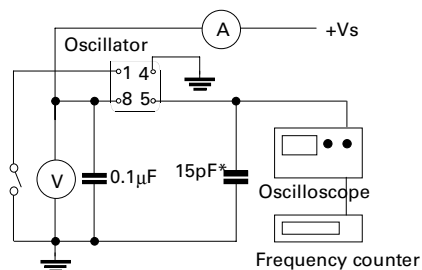

\*Inclusive of jigging & equipment capacitance

Note: Pin 1 = No connection on non tri-state models

**Test Circuit - TTL**

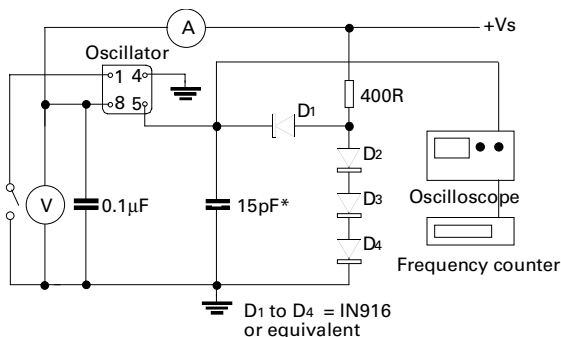

\*Inclusive of jigging & equipment capacitance

Note: Pin 1 = No connection on non tri-state models