

FGS-5S

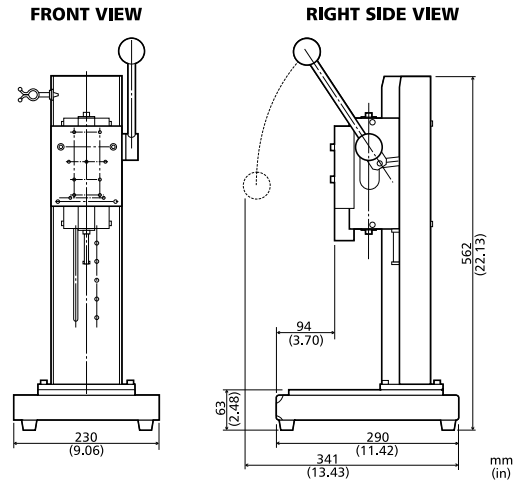

FGS-50L

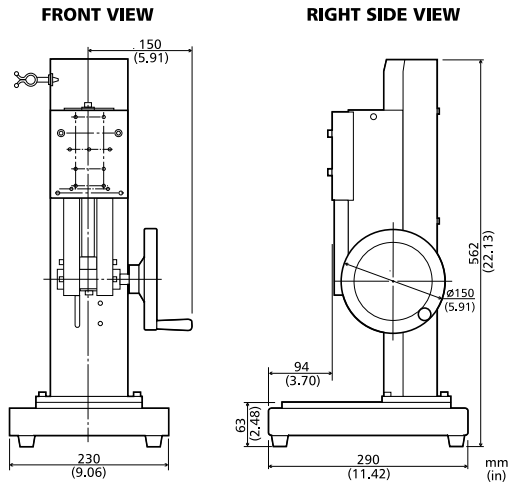

FGS-50H

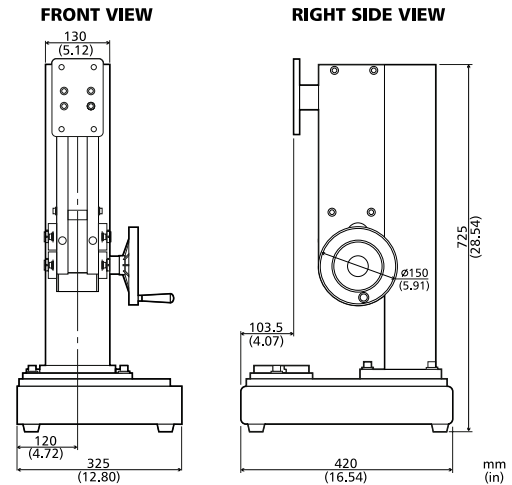

FGS-250H

HORIZONTAL/VERTICAL LEVER TEST STAND SPECIFICATIONS

Model	FGS-5S (lever)	
Capacity	50 lb (22 kg)	
Stroke	1.97" (50 mm)	
Vertical Clearance	1.6", 2.75", 3.94" (40 mm, 70 mm, 100 mm)	
Weight	22 lb (10 kg)	

VERTICAL TEST STAND SPECIFICATIONS

Model	FGS-50L (lever)	FGS-50H (hand wheel)
Capacity	110 lb (50 kg)	
Stroke	1.97" (50 mm)	5.9" (150 mm) 3 mm/wheel turn (approximately)
Vertical Clearance	3.31" - 11.57" (84 mm - 294 mm) 8 steps, 1.18"/step (30 mm/step)	2" - 7.95" (52 mm - 202 mm) 6 steps, 1.18"/step (30 mm/step)
Weight	33 lb (15 kg)	

HIGH-CAPACITY VERTICAL HAND WHEEL TEST STAND SPECIFICATIONS

Model	FGS-250H	
Capacity	500 lb (250 kg)	
Stroke	7.1" (180 mm) 0.25 mm/wheel turn (approximately)	
Vertical Clearance	9.17" (233 mm)	
Weight	132 lb (60 kg)	