

FLASHING FILAMENT

Light Sources

Power Components

Accessories

Light Transmitters



60

FLASHING FILAMENT BEACONS

Code No:	Voltage:	Light Source:	Current:
FF125-80	12v Dc ---	Ba15d x 21w	1.75 A
FF125-81	24v Dc ---	Ba15d x 21w	0.88 A
FF125-82	115v Ac ~	Ba15d x 15w	0.13 A
FF125-83	230v Ac ~	Ba15d x 15w	0.07 A

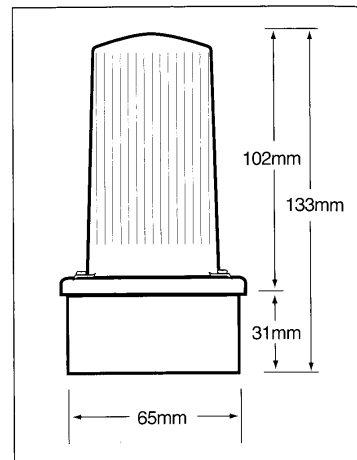

01 02 03 04 05

60 -25+66 IP 65 50/60 Hz

Kg 0.20

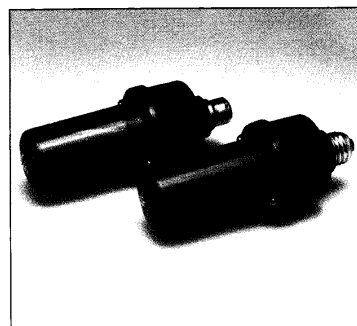

60

FLASHING FILAMENT BEACONS

Code No:	Voltage:	Light Source:	Current:
FF125ES-76	115v Ac ~	Ba15d x 15w	0.13 A
FF125ES-77	230v Ac ~	Ba15d x 15w	0.07 A
FF125BC-78	115v Ac ~	Ba15d x 15w	0.13 A
FF125BC-79	230v Ac ~	Ba15d x 15w	0.07 A

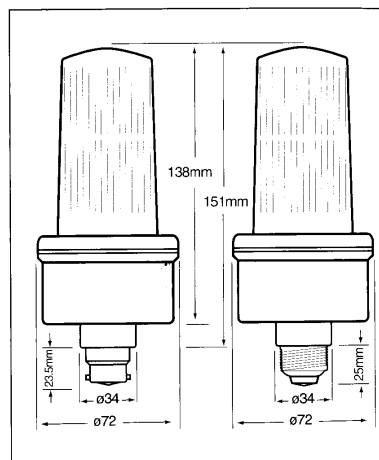

01 02 03 04 05

60 -25+66 IP 65 50/60 Hz

Kg 0.22



60

FLASHING FILAMENT AUDIBLE BEACONS

Code No:	Voltage:	Light Source:	Current:
FFA125-80	12v Dc ---	Ba15d x 21w	1.80 A
FFA125-81	24v Dc ---	Ba15d x 21w	0.90 A
FFA125-82	115v Ac ~	Ba15d x 15w	0.15 A
FFA125-83	230v Ac ~	Ba15d x 15w	0.08 A

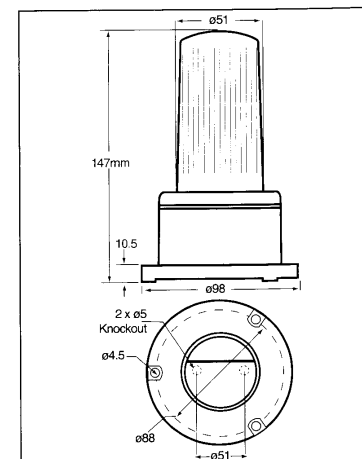

01 02 03 04 05

60 -25+66 IP 65 50/60 Hz

Kg 0.25

LED Beacons

LED 'Light Emitting Diode' beacons are ideally suited for long life applications typically achieving 100,000 hours of service. The 125 series LED beacon incorporates 48 off LED's in one enclosure and has two modes of operation, static and flashing (switch selectable on the pcb). The 201/200 & 401/400 series LED beacons incorporate 144 off LED's in one enclosure and has three modes of operation, static, flashing and rotating (switch selectable on the pcb).

Visual warning beacons communicate their message through two (sometimes three) variables:

- **Level of brightness**
- **The colour of the beacon dome**
- **Audibility if fitted with an audible signal**

Level of Brightness

Brightness depends upon the type of beacon chosen the rated power output of the unit i.e.: Watts and Joules, the distance that the signal is observed from and the dome colour of the beacon used. In general if the viewing distance is doubled the light intensity observed is reduced to a quarter and if the distance is quadrupled the light intensity is reduced to a sixteenth.

Beacon Dome Colours

The intensity of the light can be greatly reduced as it passes through the dome of the beacon. The extent of this reduction is dependent upon:

- The type of light source used i.e. conventional filament (Incandescent) bulb, tungsten halogen bulb or a xenon tube
- The colour of the beacon dome that is used.

The table below gives an indication of the percentage of light that will pass through the beacon dome for different light sources and dome colours.

COLOUR	FILAMENT	HALOGEN	XENON
Clear	100%	100%	100%
Amber	70%	70%	70%
Red	30%	27%	23%
Green	12%	15%	25%
Blue	8%	10%	13%

Different dome colours are used to convey different messages to the observer,

RED = Serious danger act now!

Amber = warning proceed with care

Green = ok proceed as normal

BLUE = specific process notice/warning

Alternatively Green colour beacons are used by Doctors and Veterinarians and Blue beacons for the police and Fire departments.

Audibility

Simply producing an audible sound when the beacon is illuminated. This is of particular use in low level noisy environments if the warning light is obscured from direct viewing or as a back-up warning should the bulb fail.

Siting and Maintenance of Visual Warning Beacons

- The siting and maintenance of visual warning beacons is as important as it's selection and application. When installing a light care should be taken to position it in the most effective place, if possible, to allow for all round light dispersion. However the following parameters should be noted.
- Always ensure that there is free air movement around the beacon enclosure as in normal operation this will warm up due to heat emitted from the light source. High power models can become quite hot over an extended period of time, therefore avoid siting the light under gantries, overhangs or in tight enclosed spaces with restricted air movement.
- Regularly clean the dome of the beacon, as this will maintain optimum light output and reduce heat build up. All domes produced by Moflash are manufactured from 'UV' stable polycarbonate plastic. Therefore do not clean with petroleum based cleaners.
- Areas of vibration should be avoided. If this is not possible then our Anti-Vibration mount 50080 should be used.
- In general it is not recommended that beacons be mounted directly onto conduit tubing without the use of a conduit box or bracket.
- To maintain the IP rating of the units the beacon must be mounted with the dome upwards and fully locked onto the base assembly. The beacon should also be suitably sealed at the point of connection using the correct cable glands.
- Xenon tube failures, unlike filament lamps, which fail immediately, deteriorate very slowly. Irregular or erratic flashing will indicate the pending failure of the tube. Once this is recognised the tube should be replaced as soon as possible. Failure to do so will result in electronic damage to the printed circuit board.

PRODUCT SPECIFICATIONS & CONFORMITIES

The CE Mark



The Moflash products that show the CE mark, are deemed to comply, where applicable, with the European Directive No: 89/336 regarding Electromagnetic Compatibility which states that 'An electrical product must not be susceptible to, or generate certain levels of, electromagnetic interference liable to interfere with other electronic equipment', and the European Directive No: 73/73 regarding low voltage electrical material which states that 'Electrical equipment within the voltage ranges of 50 to 1000v Ac and 75 to 1500v Dc are constructed within the principles of good engineering practice and provide adequate levels of protection against an electric shock'.

The Machinery Directive 89/392

The European machine directive 89/392 and its later amendments (91/368, 93/44 & 93/68) came into effect on the 1st January 1995. These directives are designed to harmonise wide ranging health and safety requirements in machinery design and daily use by indicating a potential hazard by the use of an immediately recognisable audible or visual warning signal.

prEN 842 Safety of machinery : Visual Warning Signals

Classifies the type of warning light and specifies the characteristics the warning light must achieve to conform to the machine directive.

Warning Signals

Visual warning signals must be at least five times brighter than the area where they are used.

Danger Signals

Clearly visible even in strong light, distinguishable from other lights and Visual warning signals and be understood immediately.

Emergency Signals

These have the highest priority and must be at least ten times brighter than the area that they are to be used in and understood immediately.

UL and CSA Approvals



Moflash offer a range of warning beacons that conform to the North American UL 'Underwriters Laboratories' specification requirements and the Canadian CSA 'Canadian Standard Association' specifications for visual warning beacons.

IEC 73 - Colours of Luminous Indicators & Push Buttons

Establishes the various meanings of coloured luminous indicators and push buttons to conform to the machine directive.

Colour: RED

DANGER ACT NOW
Danger of live or unguarded
Moving machinery or essential
Equipment in protected zone

Colour: YELLOW

WARNING: PROCEED WITH CARE
Temperature of pressure different
from normal level

Colour: GREEN

SAFETY PRECAUTION: GO AHEAD
Checks complete the machine
is about to start

Colour: BLUE

SPECIFIC MEANING GIVEN DEPENDING ON
SITUATION
Pre-set ready or remote control

Colour: WHITE

NO SPECIFIC MEANING
Could confirm an earlier message

All Moflash coloured domes are manufactured from 'UV' stable polycarbonate plastic that will not tarnish, fade or become brittle over a period of time unlike many domes available that are produced from Acrylic plastic.

Hazardous Areas BS 5501 - EN 50 018 to EN 50 020

The risk of an explosive atmosphere being formed is obviously a variable factor being dependent upon the conditions in a given environment. Thus in order to achieve a consistent level of safety, hazardous areas are classified into three zones as defined in BS 5345 part 1:

Zone 0

A zone in which an explosive atmosphere is constantly present, or present for long periods.

Zone 1

A zone in which an explosive atmosphere is likely to occur in normal operation.

Zone 2

A zone in which an explosive atmosphere is not likely to occur in normal operation, and if it occurs it will exist only for a short time

PRODUCT SPECIFICATIONS & CONFORMITIES

Apparatus Groups (Gas Groups)

Apparatus for use in hazardous areas is, where appropriate, grouped in one of four sub-groups, namely I, IIA, IIB, IIC. Apparatus Sub-Grouping is normally applied to Flameproof and Intrinsically safe types of protection. Other types of protection apply equally to all gases subject only to temperature classification.

The former applies mainly to apparatus designed to BS 4683 and BS 550, the following table shows the relationship between the apparatus group and the Representative gas.

Apparatus Group	Representative Gas
I (Mining)	Methane
IIA	Propane & Industrial Methane
IIB	Ethylene
IIC	Hydrogen

Maximum Surface Temperature

A gas/air mixture can ignite when it comes into contact with excessively hot surface. The surface temperature at which equipment operates is therefore of crucial importance. The equipment is temperature classified as follows:

Class	T1	T2	T3	T4	T5	T6
Max Surface Temperature in Centigrade	450C	300C	200C	135C	100C	85C







Note: The above information is intended as a guide only. The selection of Hazardous area equipment should only be undertaken by a suitably qualified Engineer and installed according to the relevant standards.

IP Ratings

The IP 'Ingress Protection' rating system provides a means of classifying the Degrees of protection from dust and water afforded by electrical equipment and enclosures. The system is recognised in most countries and is set out in BS EN60529 1992 Degrees of protection.









First Number

Protection Against Solids



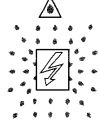
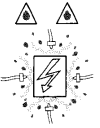

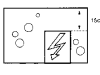

IP	Test	Description
0		No protection
1		Protection against solid objects over 50mm eg accidental touch by hands
2		Protection against solid objects over 12mm eg fingers
3		Protection against solid objects over 2.5mm [tools & wires]
4		Protection against solid objects over 1mm [tools, wires & small wires]
5		Protection against dust – limited Ingress [no harmful deposit]
6		Totally protected against dust

Second Number

Protection Against Liquids

IP	Test	Description
0		No protection
1		Protected against vertically falling drops of water
2		Protected against direct sprays of water up to 15° from the vertical
3		Protection against sprays 60° from the vertical
4		Protection against water sprayed from all directions – limited Ingress permitted
5		Protection against low pressure jets of water sprayed from all directions – limited Ingress permitted
6		Protection against strong pressure jets of water eg for use on shipdecks – limited Ingress permitted
7		Protection against the effects of temporary immersion between 15cm and 1m. Duration of test 30minutes
8		Protection against long periods of immersion under pressure

PRODUCT SPECIFICATIONS & CONFORMITIES

	Icon Legends	Legenda de Iconos	Erklärung der Abbildungen	Legendes des Icones	Legenda Icone	
		Single Flashes or Pulses per minute	Flashes simples por minuto	Einfacher Blitz oder Pulse pro minute	Signaux Clignotants ou Pulsations Simples par minute	Flash Signoli o Impulsi al minuto
		Single or Double flashes per minute. Shows the unit has a double flash option	Flashes Simples o Dobles por minuto. Muestra que la unidad tiene una opcion de doble flash	Einfacher oder Doppelblitz pro minute. Zeigt, ob das gerat die Doppelblitzfunktion hat	Signaux clignotants simples ou doubles par minute. Indigue que l' unite est equipee d' une option de signal clignotant double.	Flash singoli o doppi al minuto. Indica che il dispositivo puo fornire flash doppi
		Revolutions per minute	Revoluciones por minuto	Umdrehungen pro minute	Tours / minute	Giri al minuto
	IP	Ingress Protection of the Unit	Grado de proteccion IP	Einbruchschutz	Protection de l' unite	Indice di protezione del dispositivo
		Operating Temperature in Centigrade	Temperatura de funcionamiento	Arbeitstemperatur des gerates	Temperatures de service de l' unite	Temperatura di funzionamento in gradi centigadi
	Kg	Boxed weight including the Dome	Peso empaquetado incluida la cupula	Verpackungsgewicht einschlieblich haube	Poids conditionne, y compris partie superieure	Peso inscatolato con calotta
		Operates on a frequency of 50/60 Hz AC~	Funciona a una frecuencia de 50/60 Hz AC	Arbeitet bei 50/60 Hz wechselstrom	Fonctionne sur une frequence de 50/60 Hz CA	Funziona con 50/60 Hz in CA
		Fitted with Audible Sounder. Indicates Decibel level at 1 meter	Dispone de dispositivo acustico. Indica el nivel de decibelios a 1 metro	Mit akustischem signal versehen. Gibt lautstarke in dB in 1 m entfernung an	Equipe d' um signal sonore. Indique le niveau de decibel a 1 m	Dotato di segnalatore acustico. Indica i dB a 1m
		Lens Colours	Colores de Lentes	Linsen / Haubenfarbe	Couleur Lentille / Partie Superieure	Colore Calotta
	01	Amber	Ambar	Gelb	Jaune	Arancio
	02	Red	Rojo	Rot	Rouge	Rosso
	03	Blue	Azul	Blau	Bleu	Blu
	04	Green	Verde	Grun	Vert	Verde
	05	Clear	Transparente	Klar/Durchsichtig	Transparent	Incolore