

- Simple to use Remote Control
- 4 -16 Channel Transmitters
- Learn up to 48 Transmitter Switches per system
- Flexible Button Mapping:
 - Learn a switch to any output
 - Learn a switch to multiple outputs
- Range:
 - Up to 200 metres at 433MHz
 - Up to 500 metres at 433MHz Narrowband.
- Outputs can be Momentary, Latched or Timed (up to 15 minutes)
- Outputs Rated up to 30A @ 230Vac

The '200' series is a modular Radio Remote control system, which may be constructed by simply plugging together the desired modules.



Modular Remote Control Systems

200 Series

A Remote Control System can be constructed using a FireFly, FireBlade, '204' or '205' hand held transmitter with a 210 receiver and any combination of output module(s).

The transmitters have up to 16 buttons. Each button can be paired any or many specific outputs of the receiver. Each 210 receiver has the capacity to learn up to 48 unique transmitter switches.

The output modules can be used to provide relay controlled outputs, each of the output modules connects directly to the 210Rx.

Any transmitter switch may be married to one or many of the receiver's outputs, or a single switch may be mapped to any number of the receiver's outputs to enable a powerful and flexible remote control system. Full configuration instructions follow in section 3.

The transmitter encoder uses EMC compliant radio transmitter modules and complies with ETSI330-220

Custom systems

We regularly supply pre-wired / bespoke systems, please contact our sales dept for further assistance

**R. F. Solutions Ltd.,
Unit 21, Cliffe Industrial Estate,
South Street,
Lewes,
E. Sussex,**

BN8 6JL, England

Tel +44 (0)1273 898 000 Fax +44 (0)1273 480 661

Email sales@rfsolutions.co.uk

<http://www.rfsolutions.co.uk>

RF Solutions is a member of the Low Power Radio Association

Information contained in this document is believed to be accurate, however no representation or warranty is given and R.F. Solutions Ltd. assumes no liability with respect to the accuracy of such information.
Use of R.F.Solutions as critical components in life support systems is not authorised except with express written approval from R.F.Solutions Ltd.



FireFly Transmitters

- Robust RF Solutions design
- Compact Fob (90 x 54 x 27 mm)
- 1, 2, 4, 8 Switch Versions
- Up to 100 metres range
- Lithium Cell Battery (CR2032)
- LED Indication of Transmission
- Supplied with wall mounting holster and lanyard



Part Number	Description	Range** (Metres)	Freq (MHz)	Compatible Decoders
FIREFLY-TX1	FM Transmitter 1 Sw	100	433.92	210-433F
FIREFLY-TX2	FM Transmitter 2 Sw	100	433.92	210-433F
FIREFLY-TX4	FM Transmitter 4 Sw	100	433.92	210-433F
FIREFLY-TX8	FM Transmitter 8 Sw	100	433.92	210-433F

** Range stated is optimum, direct line of sight. In worst conditions this can be reduced

FireBlade Transmitters

- Robust RF Solutions design
- Compact Fob: 90 x 54 x 27 mm (Excluding antenna)
- 1, 2, 4, 8 Switch Versions
- Up to 500 metres range
- Lithium Cell Battery (CR2032)
- LED Indication of Transmission
- Supplied with wall mounting holster and lanyard



Part Number	Description	Range** (Metres)	Freq (MHz)	Compatible Decoders
FIREBLADE-TX1	FM Narrowband Transmitter 1 Sw	500	433.92	210-525N
FIREBLADE-TX2	FM Narrowband Transmitter 2 Sw	500	433.92	210-525N
FIREBLADE-TX4	FM Narrowband Transmitter 4 Sw	500	433.92	210-525N
FIREBLADE-TX8	FM Narrowband Transmitter 8 Sw	500	433.92	210-525N

** Range stated is optimum, direct line of sight. In worst conditions this can be reduced

204 Transmitters

- Pocket Fob with Wall Mounting Holster (96 x 47 x 23mm)
- 4, 8/16 Switch Versions
- Range;
 - 433MHz Up to 100 Metres
 - 458MHz NB Up to 500 Metres
- Lithium Cells Battery (CR2016)
- LED Indication of Transmission



The 8/16 unit has 8 switches and a 'shift' key, pressing the shift key causes the LED to change from Red to Green shifting the switches as either 1-8 or 9-16.

Part Number	Description	Range** (Metres)	Freq (MHz)	Compatible Decoders
204C4-433F	FM Transmitter 4 Sw	100	433.92	210-433F
204C16-433F	FM Transmitter 8/16 Sw	100	433.92	210- 433F
204C4-525N	FM Narrowband Transmitter 4 Sw	500	434.525	210-525N
204C16-525N	FM Narrowband Transmitter 8/16 Sw	500	434.525	210- 525N

** Range stated is optimum, direct line of sight. In worst conditions this can be reduced

205 Transmitters

- Hand Held Tx
- Rugged 'Polypropylene' Enclosure IP67
- 8 or 16 Switch Version
- Coloured Switches IP67
- Range;
 - 458MHz NB Up to 500 Metres
- Battery Type 2 x CR2016
- Dimensions, excluding Antenna:
90 x 250 x 41mm (w x h x d)



Part Number	Description	Range** (Metres)	Freq (MHz)	Compatible Decoders
205C8-525N	FM Narrowband Transmitter 8 Sw	500	434.525	210-525N
205C16-525N	FM Narrowband Transmitter 16 Sw	500	434.525	210- 525N

** Range stated is optimum, direct line of sight. In worst conditions this can be reduced

Receivers

- 16 Output Channels
- Volt Free contact Inputs via Screw Terminals
- 12 / 24Vdc Supply
- Antenna Supplied

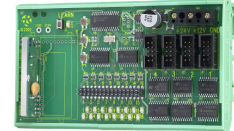

Part Number	Description	Range** (Metres)	Freq (MHz)	Compatible Transmitter
210-433FR	FM Receiver	200	433.92	204/205-433F
210-525NR	FM Narrow Band Receiver	500	434.525	204/205-525N

Output Modules

- Connect Directly to 210 Rx (Cable Supplied)
- no power connections required



Part Number	Description	No of Outputs	Max Switching (per output)
215	Relay Module	8	5A @230Vac
216	Relay Module	4	12A @230Vac
230	Relays Module	4	30A @230Vac

Enclosure / Power Supply

- IP56 Insulation Class 2
- DIN Rails mounted on Steel Plate
- 12Vdc 1A PSU incorporated accepts 110-240Vac (5A Fused)

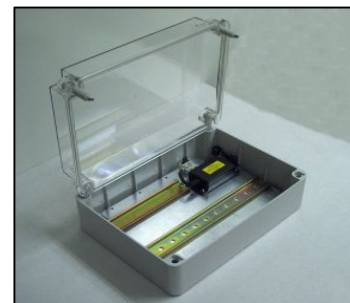

Dimensions

External	315 x 235 x 130mm
Internal	300 x 220 x 120mm
DIN Rail length 1	285mm
DIN Rail length 2	180mm

Part No	Description
ENC-DA3	DIN Rail Enclosure Assembly, Two Mounting Rails, 12Vdc PSU Fitted
PSU12V1AIN-IP	Power Supply 110-240Vac input, 12Vdc 1A Output

1 Pre-Configuring the Remote Control System

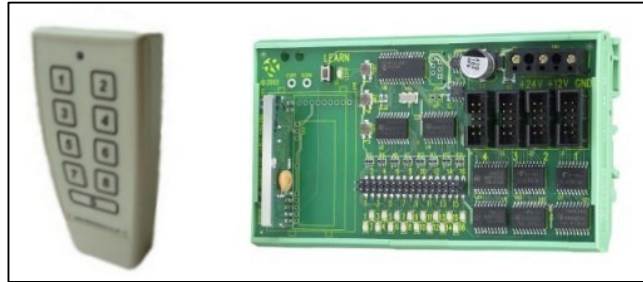

There are three Steps:

1. Pre-Configure the 210Rx to operate with a type of Transmitter (e.g. the 204 range or 205 range)
2. Map the Transmitter(s) switch(es) to the 210Rx output(s)
3. Set the 210Rx outputs to be latching, momentary or timed.

1.1 Pre-Configure the 210Rx to operate with a Transmitter Series

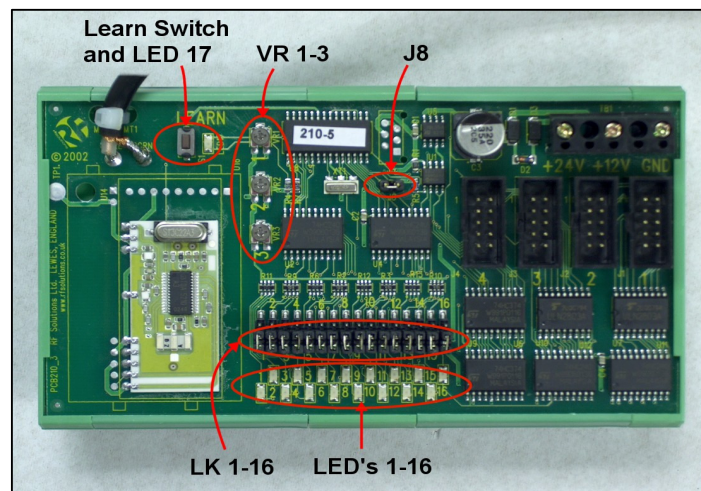

1. Ensure option link J8 is open.
2. Apply power to the 210Rx, All output LEDs flash alternately. This is factory reset default state.
3. Briefly Press any switch on the transmitter.
The 210Rx will now confirm this by flashing LED 1 to show it is configured for use with a handheld transmitter.
Note This will now happen at each power on.

Mapping a Transmitter Switch to a 210 Receiver Output

One or many transmitter switches may be mapped to one or many 210Rx outputs, Decide which switch on the Transmitter is to operate which output channel on the 210 Receiver decoder.

1. Briefly press the 210 Rx learn switch until the LED1-16 indicates the desired output channel
2. Operate the desired transmitter switch briefly
3. The LED on the 210Rx will extinguish.
4. Operate the desired transmitter switch briefly again
5. The LED on the 210Rx will turn on briefly and then extinguish.
6. The selected transmitter switch will operate the 210Rx output channel.

This procedure may be repeated for each transmitter and each 210Rx output required.

1.2 Configuration of the 210Rx Receiver Decoder Outputs

Option links LK 1-16 configure the operation of the outputs. Please note that the link status is read only on 'power up' and thus after changing the links, power must be removed and re-applied.

LK 1-16	Output 1	Outputs 2 -16
Open	Mom or Timed	Mom (The O/P operates for as long as the transmitter switch is held on)
Connected	Latch or Timed	Latch (The O/P changes state each time the Transmitter is operated)

1.2.1 Setting the Timed output (Channel 1)

This is set by VR1 with a delay of from 0 to 15 minutes. To set the time delay:

1. Remove power.
2. Place a shorting link header on option link J8.
3. Apply power
4. Depress and release the learn button twice.
5. The 210Rx will then enter the 'time set mode'
6. LED1 will illuminate, indicating that output 1 time delay is to be set.
7. Using a fine screwdriver, adjust potentiometer VR1.
8. An indication of the time delay set is shown by LED's 9-15.

After setting the timed output the unit must be powered down and option link header J8 removed before it can be used.

1.3 Erasing the 210Rx Receiver Outputs (Return to Factory Default State)

1. To completely erase the 210Rx decoder's memory, press and hold the 210Rx learn switch.
2. The learn LED (LED 17) will illuminate
3. Hold the Learn switch until the learn LED extinguishes (approx 10 seconds).
4. Release the learn button and all the output LED's 1-16 will now flash alternately to indicate that all encoder data has been erased and the 21Rx has returned to factory default state.

Note: It is not possible erase individual transmitters.

1.4 Connecting output Modules to the 210 Receiver

A range of '200' series output modules are available which can be plugged into the 210 Receiver via the four IDC header boxes on the receiver. The selection of output module will be dependant on the application. Please see DS200S-1 for a summary the available modules and references to individual datasheets for each output module.

2 Antenna and Range

2.1 Connecting an Antenna

The 210Rx has a 300mm flying lead cable (50ohm) with a panel mount BNC socket provided to mount on an enclosure. This cable may be extended however please note that typically there is a 50% range reduction with every 3metres of coax cable used!

For increasing range performance a +3dB gain antenna is available. This is supplied with wall mounting bracket and 2metres of coax cable, it plugs in directly to the 210Rx BNC connector.

2.2 Range

The antenna choice and position directly controls the system range. Keep it clear of other metal in the system. The best position by far, is protruding from the top of the product. This is often not desirable for practical or ergonomic reasons and thus a compromise may be needed. If an internal antenna must be used then try to keep it away from other metal items, and in particular large ones like transformers, batteries and PCB tracks and earth planes.

Note that the space around the antenna is as important as the antenna itself. All radio systems are dependant on a radio signal being received through airspace.

The range quoted is the optimal in direct line of sight without obstacles and in good atmospheric conditions.

Range is affected by many things, for example local environmental conditions, atmospheric conditions, interference from other radio transmitters. For evaluating the local environment please see our RF Meter (DS006)

In very worse case applications the range quoted may be reduced to 30% of the optimal range stated.

2.3 Signal integrity

In systems where many encoders are in close proximity there may be occasions when, due to signal overlay between encoders, it is difficult or impossible to guarantee system integrity. In such circumstances it is the responsibility of the installer to ensure that the system performance is adequate for the purposes of the installation.

2.4 Information availability

All products are supplied with their relevant datasheets. These are also available for download from the website or on request from RF Solutions Ltd.

3 Module Technical Specifications

Receivers

Connector	O/P Channels
1	1 - 4
2	5 - 8
3	9 - 12
4	13 - 16

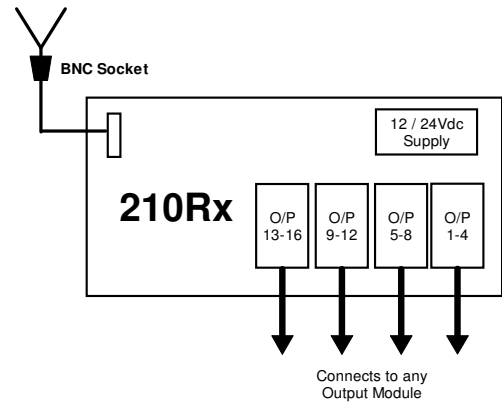

Technical Specifications

Dimensions: Within DIN Rail: 138 x 82 mm (PCB: 133 x 72mm)
Storage Temperature: -10 to +70° Celsius. **Operating Temperature:** 0 to +55° Celsius.

Electrical Characteristics	Min	Typical	Max	Units
Supply Voltage: 12V Supply	10	12	16	V
Supply Voltage: 24V Supply	21	24	30	V
Supply Current : Quiescent		25		mA
Time from Tx Switch depressed to 210Rx output			100	mSecs
Time from Tx Switch release to Decoder output			200	mSecs
Switched output Voltage (I out = 1mA)				
Logic Low	0	0.2	0.8	V
Logic High	3.5	3.8	5	V

Part Numbering

Part No	Description
210-433FR	Receiver Decoder 16 Channels DIN Rail Mounting, FM @ 433.92MHz
210-525NR	Receiver Decoder 16 Channels DIN Rail Mounting, FM Narrow Band @ 434.525MHz
210-458FR	Receiver Decoder 16 Channels DIN Rail Mounting, FM High Power @ 458.850MHz

Output Modules

215 Relay Output Module

- 8 relay switches rated 230Vac at 5A
- Each relay provides 'input' and 'normally open' screw terminals

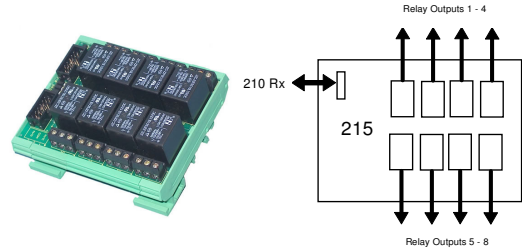

Dimensions: Within DIN Rail: 93 x 82 mm (PCB: 90 x 72mm)
 Storage Temperature: -10 to +70° Celsius. Operating Temperature: 0 to +55° Celsius.

Electrical Characteristics	Min	Typical	Max	Units
Supply Voltage	From 210Rx module			
Relay* output Rating Type HRS1KH3-12	Max rating is 3A/220VAC/30VDC			

***The relay contacts in this unit are for functional use only and must not be used for isolation purposes**

216 Relay Output Module

- 4 relay outputs rated at 230Vac ,12A peak and 5A continuous current rating.
- 'normally open' and 'normally closed' screw terminals.

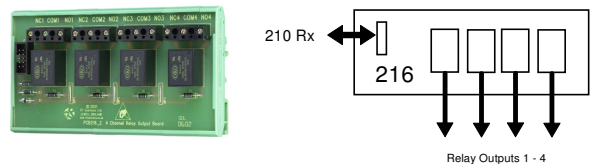

Dimensions: Within DIN Rail: 135 x 82 mm (PCB: 132 x 72mm)
 Storage Temperature: -10 to +70° Celsius. Operating Temperature: 0 to +55° Celsius.

Electrical Characteristics	Min	Typical	Max	Units
Supply Voltage	From 210Rx module			
Relay* output Rating (type KB12) at 230Vac		5	12	A

***The relay contacts in this unit are for functional use only and must not be used for isolation purposes**

230 Relay Output Module

- 4 relay (type K7SFA12) outputs rated for up to 30A at 230Vac.
- Each relay provides 'input' and 'normally open' Spade Terminals.

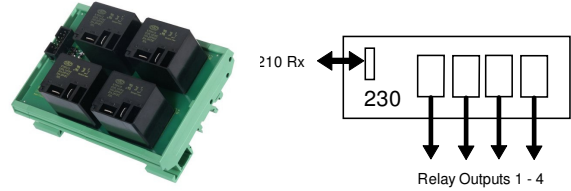

Dimensions: Within DIN Rail: 115 x 82 mm (PCB: 109 x 72mm)
 Storage Temperature: -10 to +70° Celsius. Operating Temperature: 0 to +55° Celsius.

Electrical Characteristics	Min	Typical	Max	Units
Supply Voltage	From 210Rx module			
Relay output Rating @ 230Vac*			30	A
@ 12Vdc			20	A

*The relay contacts in this unit are for functional use only and must not be used for isolation purposes

R. F. Solutions Ltd.,
Unit 21, Cliffe Industrial Estate, South Street, Lewes,
E Sussex, BN8 6JL. England

Tel +44 (0)1273 898 000 Fax +44 (0)1273 480 661

Email sales@rfsolutions.co.uk <http://www.rfsolutions.co.uk>

RF Solutions is a member of the Low Power Radio Association