



# Quam

## 8C5PAX

### 8" Dual Cone Loudspeaker

#### 0203 - LOUDSPEAKER, INDIVIDUAL

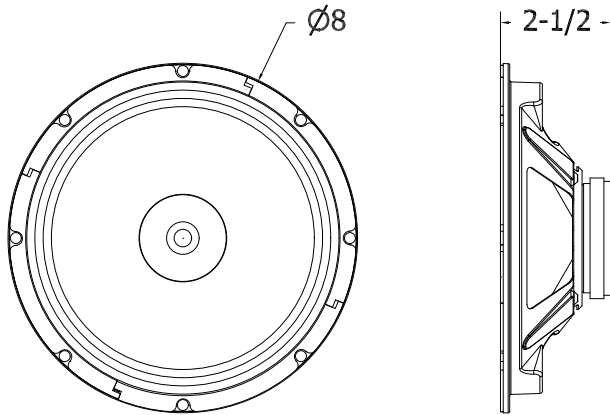

#### GENERAL DESCRIPTION

The Quam 8C5PAX is an 8" frame, 8 Ohm loudspeaker with concentric mount hard fiber HF cone. Finish: Black baked epoxy hybrid.

#### INTENDED USE

Wide frequency response replacement loudspeaker or combined with recommended Quam components to form a complete loudspeaker system; indoor environment.

Program Material: Signal tones, voice and music

#### SYSTEM COMPONENTS

N/A

#### RECOMMENDED ADDITIONAL QUAM COMPONENTS

Refer to Section 0104.6 - Customer Specified Assembly or individual components listed below:

- 0502- Transformers
- 0301- Baffles, Round -or-
- 0302- Baffles, Square
- 0401.1- Flush Mounted Back Boxes, Round -or-
- 0401.2 Flush Mounted Back Boxes, Square
- 0402- Loudspeaker Mounting Devices

#### AUDIO SPECIFICATIONS

Speaker Size	8" frame
Average Sensitivity	92 dB SPL, 1W/ 1M
Power Rating	12W RMS, EIA 426A Standard
Calculated Output	103dB SPL, 10W/ 1M
Magnet Type, Weight	BeFe Ceramic, 4.8oz. Nominal
Frequency Response Nominal	65Hz - 17 kHz EIA 462A Standard
Coverage Angle	100° Included Angle,
Mounting	-6 dB / 2 kHz, Half space
Audio Connection	8x 1/4" Holes spaced 45° apart On 7-5/8" circle
	0.205" Spade lug

Recommended construction sequences, installation instructions and A&E Specifications are available in various formats on the Quam Architects' and Engineers' Resources CD or on the web at: [www.quamspeakers.com](http://www.quamspeakers.com)

#### Quam-Nichols Company

234 East Marquette Road, Chicago, IL 60637  
 Phone: (800) NEED NOW Fax: (888) NEED NOW  
 (800) 633 - 3669 (888) 633 - 3669  
 E-Mail: [neednow@qnc.com](mailto:neednow@qnc.com) [www.quamspeakers.com](http://www.quamspeakers.com)

© 2009 Quam-Nichols Company Quam-Nichols reserves the right to make changes and/or improvements to its products at any time and without notice.



T8C5PAX\_09MY08

02

LOUDSPEAKERS, INDIVIDUAL