

keene electronics K-LAB-20

KLAB20 20W STEREO AUDIO AMP THAT FITS FLUSH TO THE WALL!

Overview

The Keene K-LAB-20 is ideal for use in multi-room audio installations. It is a high quality stereo audio amplifier that's built into a std sized UK double pattress. It provides 20W (RMS per channel) of amplification eliminating the need to make space for a conventional amplifier. It draws it's own power from an externally located mains adaptor and control is by infra red remote.

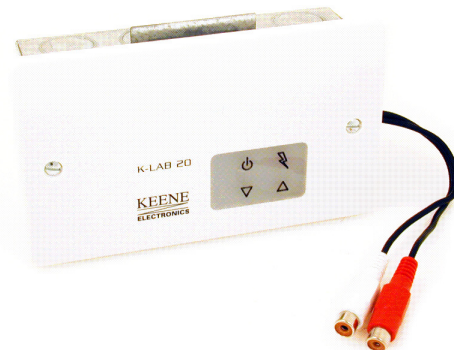

Installation

Installation should only be carried out by a qualified installer or electrician, as a certain amount of electrical knowledge is assumed.

- 1 Cut a hole in the wall large enough to mount the amp, (35mm depth) and cut channels or use conduit for the cables.
2. The amp is mounted with the LED window downwards.
3. Remove the faceplate from the amp.
4. Holes are provided in the pcb to allow use of the original pattress mounting slots use 2 screws into the slots to fix the amp to the wall. If fixing in a studded wall you will need to attach the supplied metal lugs for plasterboard fixing.
5. Feed the speaker cables through the 2 top holes, the signal cables through the lower right hole and the power supply connector through the lower left hole. Note power supply is 10 to 15 V DC centre positive and must be capable of at least 2.5A if you are not using the recommended psu please verify that the supply is correct BEFORE connecting it to the amp. If using the recommended supply we suggest that it is connected in accordance with the instructions in section 9 below. The amp can be used from a car battery or for that matter a car with engine running but NOT directly from a car battery charger as these can damage the unit
6. In order to make a reliable and safe connection without short circuits it is recommended that the speaker cables and signal cables are prepared and tinned prior to connection, with no more than 1/4" or about 7mm of tinned wire extending out of the insulation.
7. Connect the speakers being careful to keep both left and right connections the same. As the amp is fully bridged there is NOT a common ground or return connection so if the positive speaker connection for the left speaker is connected to terminal "A", the same should be connected on the right speaker. It should be noted that the recommended minimum speaker impedance is 4 ohms on each channel, if driving 2 speakers or more on each channel use them in series if they are both 4 ohms or parallel if they are both 8 ohms. Note the speaker corresponding to the left input is actually on the right hand terminals in the amp as viewed from the front.

Installation continued..

8. Connect the input signal cables using tinned cable. Connect the screens to the 2 centre connections and the 2 signal wires (centre cores) to the top and bottom connectors. Note all the connectors are of the superior rising clamp style so that they make a sound connection without biting through the copper of the cable. Also supplied is a short cable with phono line sockets to open end that can be used to provide trailing line sockets should you prefer.

9. Finally plug in the power supply. If using the recommended supply we suggest that it is hidden in the cavity wall or another dummy part. **The mains connection should be via a fused and switched mains outlet such as order code SWL1 from Keene Electronics.**

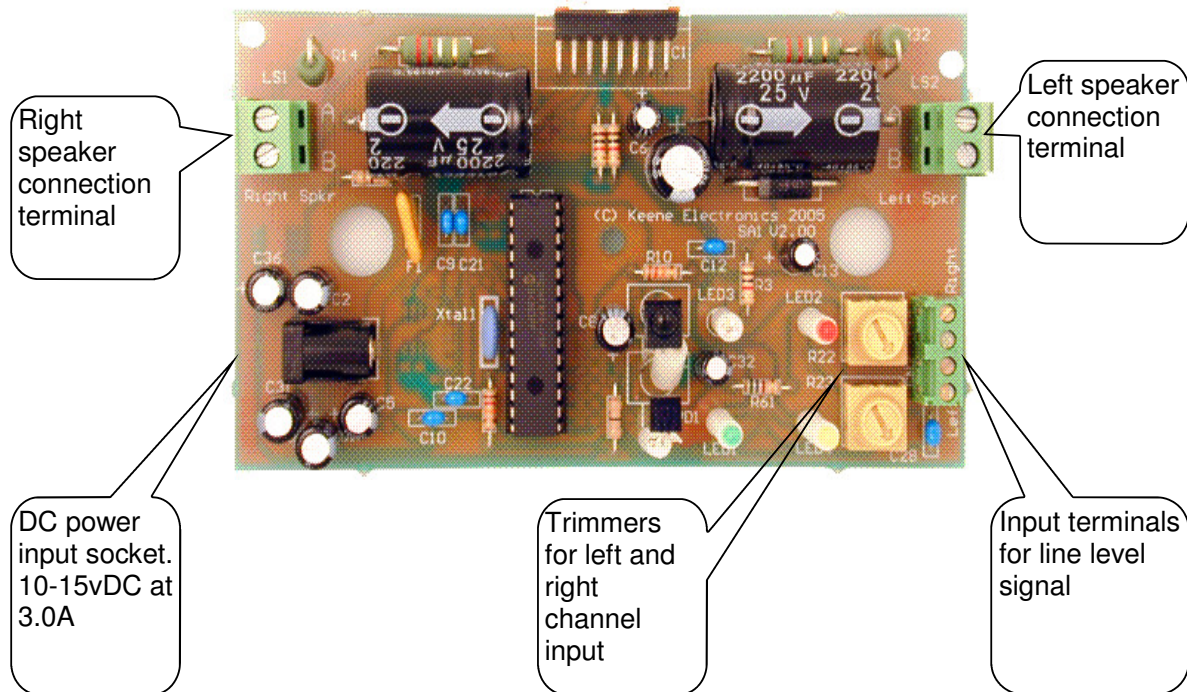

10. Double check all connections and, if all is well switch on. The red and blue LEDs will illuminate, replace the faceplate and refer to the operating instructions.

11. The trimmer controls independently attenuate the left and right channels and may be used to compensate for any imbalance in the input signal and to fine tune for loudspeaker placement. The default is maximum for both channels.

12. Use in bathrooms etc, The unit is not IP rated for use in damp environments but if due care is given to positioning of the mains supply and to water proofing of the amp (such as mounting behind a Perspex panel or sealing the unit) then it should be capable of operating in such an environment. Please use a qualified electrician operating to current regulations if you intend to use this unit in a bathroom.

Operating instructions

Firstly please note that the volume control system used does not go to zero volume a standby button is provided for when you require the unit to produce no sound.

There are 256 steps to the volume control from a minimum volume of 0 to a maximum volume setting of

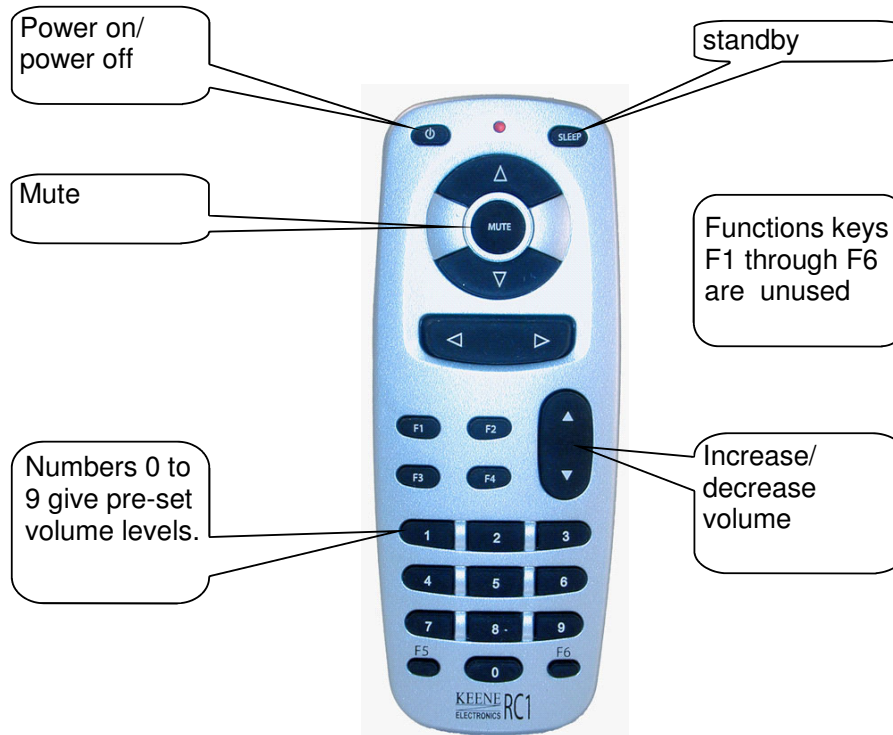

255. These are accessed by pressing the volume up and volume down buttons.

The 10 number keys from zero (minimum) to 9 (maximum) provide a range of preset volumes within this range.

Pressing the mute button will take the amp to an extremely low volume.

The sleep button will switch it to standby. When in standby any active button will restore the amp to operation. The amp remembers the volume setting that was in use when it went into standby, on restore it will select either the stored volume or the volume of the key pressed whichever is the lower. On first key press the volume is deliberately inhibited at 50% of maximum. Subsequent key presses will allow higher volumes to be selected.

The power will also put the unit into standby although only the power button can be used to switch the unit back on again.

It is safe to leave the amp in standby as very little current is used in that mode. In standby only the Red power LED will be illuminated. This is the normal method of switching off the amp.

All the LEDs are configured to fade as the ambient light level drops; this is so that the led brightness does not look excessive even in a darkened bedroom.

In the event of a power failure the amp will resume operation in the same state (on or standby) and at the same volume setting when power is restored.

The amp should have been wired via a switched fused mains outlet if you have any reason to suspect the

Specifications:

amp has a fault please switch off at the mains and consult your installer.

Power output: 20W RMS per channel into 4ohms
Distortion: < 1% typically less than 0.2% up to rated power
Bandwidth: 20Hz to 20KHz Passive limitation built in
Supply: 10V to 15V (absolute max 18V DC) minimum current 3.0A. Connection via a 2.1mm DC connector centre positive, auto mute on under voltage.
Fuse: self resetting 3A built in – to clear remove power for at least 20 seconds, clear fault and reconnect
Amplifier topology: full bridge mode all speaker connections are live (no common ground connection)
Recommended minimum speaker impedance: 4 ohms per channel
Absolute minimum speaker impedance: 2 ohms per channel
SNR: 60dB
Voltage gain: 27dB
Input required to produce full output: approx 775mV

Extras you may find useful:

Ceiling mount loudspeakers [CMS8U]

Switched Spur outlet
An MK style switched fused spur outlet, ideal for making a safe connection to the KLAB20 power supply. [SWL1]

