

# Wi-Sys Communications Inc.

## WS3914 Low Current GPS Antenna

### Applications:

- ◆ Automotive Navigation
- ◆ Fleet Management & Telematics
- ◆ Marine Navigation
- ◆ Asset Tracking
- ◆ Military Radio and Vehicle
- ◆ Law Enforcement



The WS3914 GPS antenna uses the same advanced circuitry as our high performance WS3910 antenna, redesigned to operate on only 2 mA of current – setting a new standard for the industry. Performance is not sacrificed; the antenna still features a custom designed ceramic patch element along with a patented low noise amplifier and SAW filter, enabling the WS3914 to provide a consistent, clear signal while minimizing loss-of-lock. The WS3914 antenna is ideal for portable applications where low power operation is a necessity.

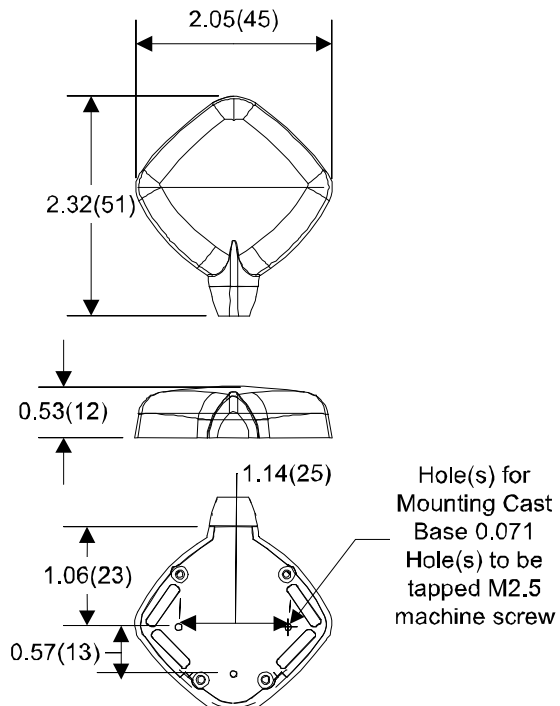

### Features:

- ◆ Extremely low current:  
2 mA @ 2.7 VDC
- ◆ Very low noise figure:  
1 dB
- ◆ Excellent out-of-band  
signal rejection
- ◆ High performance  
patented LNA
- ◆ Wide range of connector  
types available
- ◆ Wide voltage input range  
(2.5 – 3.3 VDC)



a time and place...  
for everything

## Wi-Sys Communications Inc.

### WS3914 GPS Antenna

*Designed for low power use while maintaining GPS performance, the WS3914 antenna's advanced circuitry integrates a SAW filter and low-noise amplifier to ensure a reliable and clear signal for the GPS receiver even in difficult conditions. The antenna design and industry leading low current draw makes the WS3914 antenna ideal for portable or telematics applications using MONITOR, STANDBY or SLEEP modes.*

### The Wi-Sys Antenna Family

**WS3910:** High gain, low noise GPS antenna

**WS3916:** Low cost GPS antenna

**WS3917:** Low cost filtered GPS antenna

**WS3940:** Active GPS + Cellular Combined Glass mount/covert antenna

**WS3942:** Active GPS + Cellular Combined Magnetic mount antenna

**WS3950/WS3960:** High gain, low noise Embedded antenna

**WS3954/WS3964:** low current Embedded GPS antenna

**WS3957/WS3967:** low price filtered Embedded GPS antenna

**WS3977:** Through-hole Mount GPS Antenna

## Technical Specifications

### Environmental Specifications

- ◆ -40c to +80c operating (-45c to +80c storage)
- ◆ Humidity: 95% max (non condensing)

### Mechanical

- ◆ 45mm x 51mm x 12mm (2.05" x 2.32" x 0.53")
- ◆ 120g (4.2 oz)
- ◆ Attachment methods: Magnetic (5 lb lift-off force) or permanent (pre-threaded for 3x M2.5 screws)
- ◆ Shock: Vertical axis 50G Other axes 30G
- ◆ Vibration: 3 axis, sweep = 15 min  
10 –200 Hz log sweep: 3G

### Antenna Response

- ◆ Frequency: 1575.42 MHz
- ◆ Gain: @ 90° 3 dBic  
@ 20° -2.0 dBic
- ◆ Polarization: Right Hand Circular
- ◆ Axial ratio: @ 90° 4 dB  
@ 20° 6 dB

### Electrical

- ◆ Voltage: 2.5 – 3.3 VDC
- ◆ Current: 2.0 mA @ 2.7VDC (typical)
- ◆ Cable: 1.5 DS-QEHV Shikoku Cable Co. Ltd.
- ◆ Cable loss: 1.3 dB/m typical
- ◆ Cable Length: 3 meter standard, other lengths optional
- ◆ Connector: SMA standard  
SMB, SMC, MCX, BNC, TNC optional

### LNA Specifications

- ◆ Frequency: 1572.5 – 1578 MHz
- ◆ Output Impedance: 50 Ohm
- ◆ VSWR: 1.5:1 max (at connector)
- ◆ Gain: @ 3.3VDC: 18 dB (typical)
- ◆ Noise figure: 1 dB
- ◆ Out-of-band rejection: + 15 MHz: 10 dB/- 15 MHz: 30 dB  
+ 20 MHz: 20 dB/- 20 MHz: 30 dB  
+ 40 MHz: 40 dB/- 40 MHz: 40 dB

### Wi-Sys Communications Inc.

31B Richardson Side Road  
Ottawa, ON K2K 0A1 Canada  
Tel 613.254.7386 Fax 613.254.7388  
sales@wi-sys.com www.wi-sys.com

