

PAULSTRADYN®

New !

Natural frequency :

- axial 7 Hz
- radial 3 to 5.5 Hz



ADVANTAGES

- Better than 90% isolation at 1.500 rpm (25 Hz).
- Constant height over wide load range.
- Stabilised characteristics during Service Life.
- Simple to fit.
- 400 hours protection against salt spray*.
- Design.

* When mounted according to the recommendations given in the catalogue.



Finite element modeling

New formula SILTECH

- Low increase of stiffness with frequency
- Low creep

APPLICATIONS

Anti vibration isolation for static equipment :

- rotating machinery such as fans, air-conditioning, pumps, compressors, generator sets.
- pipework, ceilings, transformers, electrical enclosures.

DIMENSIONS

Fig. 1

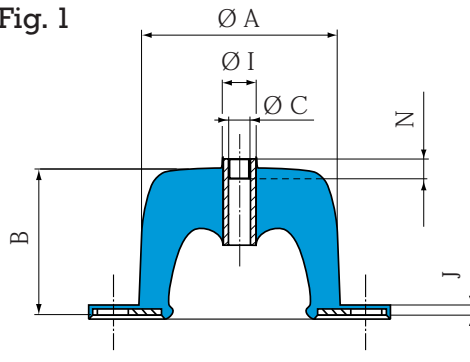
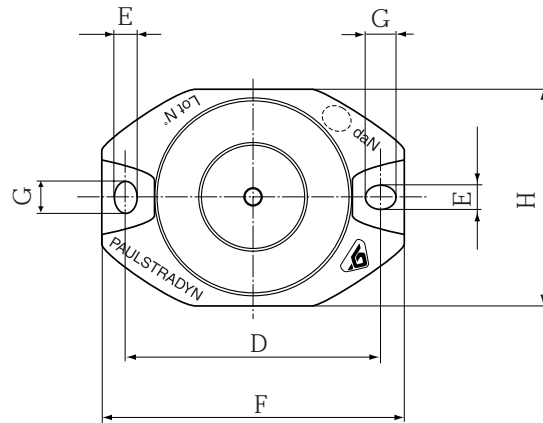
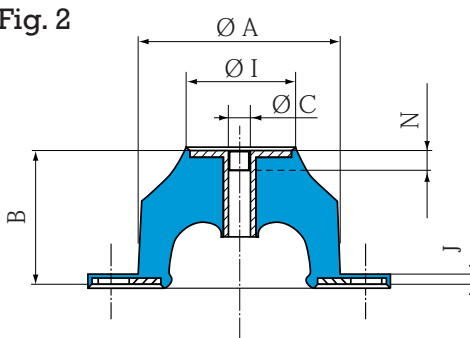

Fig. 2



Designation	Ref.	Nominal load NL (daN)	Fig.	Dimensions (mm)											
				Ø A	B*	Ø C	D	E	F	G	H	Ø I	J	N	
Paulstradyn	4 7 12	533701 533702 533703	4 7 12	1	40	40	M6	52	6.2	64	6.2	44	12	2.5	6
Paulstradyn	20 30 50	533704 533705 533706	20 30 50	2	60	40	M6	76	6.2	90	8.2	64	32	2.5	6
Paulstradyn	70 100 130	533707 533708 533709	70 100 130	2	80	40	M8	100	8.2	122	12.2	84	48	2.5	12
Paulstradyn	160 200 260	533710 533711 533712	160 200 260	2	100	40	M10	124	10.2	152	16.2	104	68	3	10
Paulstradyn	325 400 500	533713 533714 533715	325 400 500	2	150	40	M12	182	12.2	214	20.2	154	116	4.5	10
Paulstradyn	640 820 1050 1350	533716 533717 533718 533719	640 820 1050 1350	2	200	40	M16	240	14.2	280	24.2	204	159	5.5	20

* : Height, unloaded 40 mm, under load 32 mm (see Technical Characteristics).

NL : Nominal static load with mounting under axial compression.



TECHNICAL CHARACTERISTICS

The vibration attenuation and height characteristics under nominal load are **stabilised after one month under load at 20°C**.

Common characteristics

- Natural axial frequency 7 Hz, with nominal load.
- Natural radial frequency 3 to 5.5 Hz.
- Maximum displacement :
 - axial : 12 mm.
 - radial : ± 10 mm.

Vibration attenuation

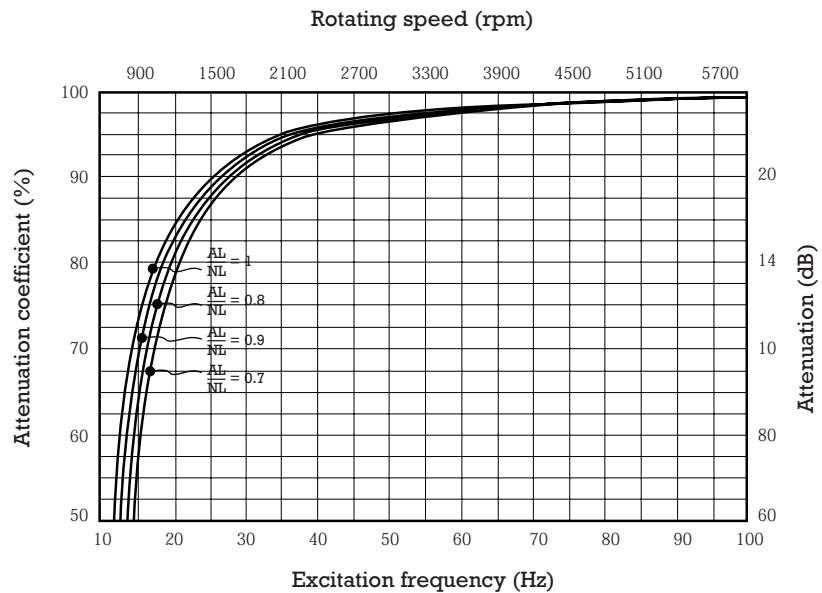

$$\frac{AL}{NL} = \text{Ratio} \frac{\text{Actual load}}{\text{Nominal load}}$$

Height under load

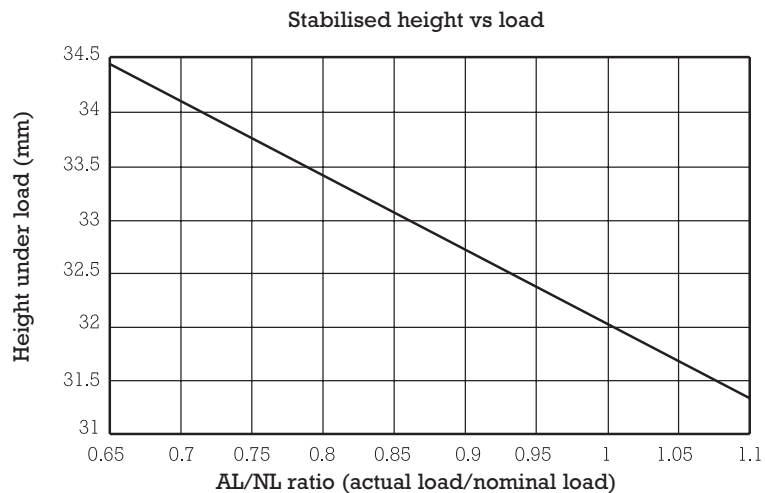

Temperature

Operating temperature : - 20°C to + 70°C.

Other characteristics*

- Good dynamic performance at high frequency.
- Withstands fatigue and shocks.
- Reduced creep.

* Detailed Technical Characteristics can be sent on request. Ask us for details.



MOUNTING

Standard mounting

- ① machine base or foot
dimensions > $\varnothing M^*$
- ② supporting structure (floor)
dimensions > base of mounting F x H* (refer
page 39)
- ③ screw $\varnothing C^{**}$
- ④ screw $\varnothing K$, a washer is required between the screw
head and the PAULSTRADYN*
- ⑤ screw $\varnothing K$, a washer is required between the
screw head and the PAULSTRADYN*

Note : * to distribute the load and resist corrosion
** nuts and screws grade 4.6 minimum.

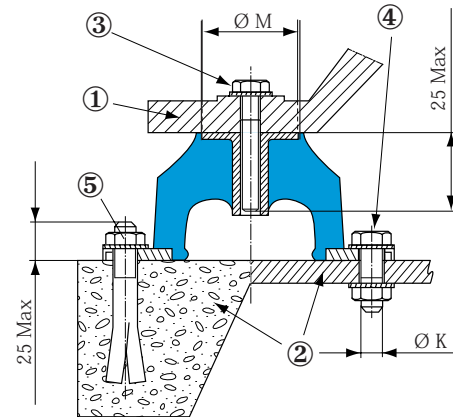

ON CONCRETE ON CHASSIS

Fig. 1

Recommended torque

Diameter K (mm)	M6	M8	M10	M12
torque N.m.	2	5	12	20

Note : Do not paint the mountings after fitting.

Alternative mounting

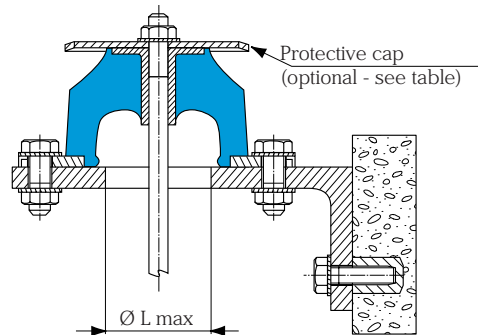

Fig. 2

Mounting and cap references

Paulstradyn references	Dimensions (mm)			Réfrence coupelle (en option)
	$\varnothing K$ Fig. 1	$\varnothing L$ max Fig. 2	$\varnothing M$ max Fig. 1	
533701, 533702, 533703	M5	27	14	342919
533704, 533705, 533706	M5	40	34	342356
533707, 533708, 533709	M6	46	50	342733
533710, 533711, 533712	M8	47	70	342734
533713, 533714, 533715	M10	99	118	342353
533716, 533717, 533718, 533719	M12	127	162	342354