

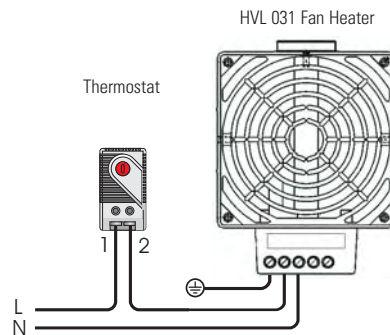

Shown: 100W - HVL 031 Fan Heater

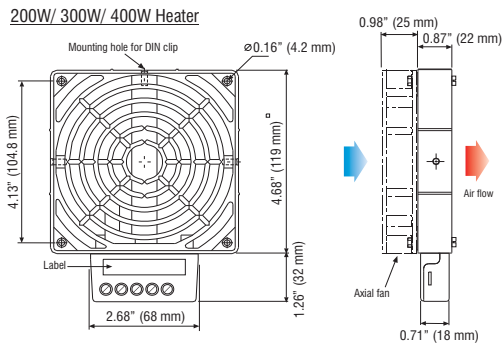

Important! Heater must be operated together with a fan. Operating without a fan creates the danger of overheating.

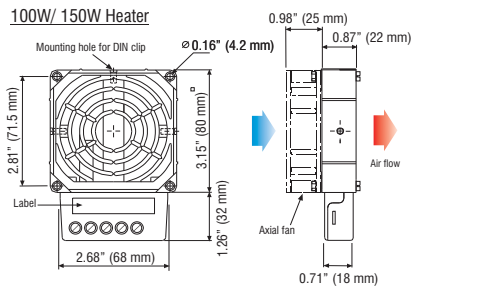

- Compact size**
- Flat design**
- Built-in overheat protection**
- 3-side DIN rail mountable**

The compact HVL 031 high-performance fan heater prevents formation of condensation and provides an evenly distributed interior air temperature in enclosures. For large OEM use, this fan heater can also be provided without the fan, in which case the OEM/customer must provide a fan which meets the minimum airflow requirements.



Technical Data

Heating element	high performance cartridge
Overheat protection	built-in temperature limiter
Heater body	die-cast aluminum, glass bead finish
Connection	3-pole terminal AWG 14 max. (2.5mm ²), torque 0.8Nm max..
Connection housing	plastic, UL 94V-0, black
Mounting	clip for 35mm DIN rail, EN 60 715
Mounting position	horizontal
Operating / Storage temperature	-49 to +158°F (-45 to +70°C)
Protection class / Protection type	I (grounded) / IP20
Axial fan, ball bearing	service life 50,000h at 77°F (25°C)
Air flow, free blowing	see table below
Axial fan connection	2-pole terminal AWG 14 max. (2.5mm ²), terminals L2/N2
Approvals	UL File No. E187294 (all), VDE (230VAC only)

Part No. - 120VAC	Part No. - 230VAC	Heating capacity	Min. airflow (free blowing)	Dimensions (as mounted)	Weight (approx.)
03102.9-00	03102.0-00	100W	20 cfm (35m ³ /h)	1.85 x 3.15 x 4.41" (47 x 80 x 112mm)	1.3 lbs. (600g)
03103.9-00	03103.0-00	150W	20 cfm (35m ³ /h)	1.85 x 3.15 x 4.41" (47 x 80 x 112mm)	1.3 lbs. (600g)
03113.9-00	03113.0-00	200W	63 cfm (108m ³ /h)	1.85 x 4.68 x 5.94" (47 x 119 x 151mm)	2.0 lbs. (900g)
03114.9-00	03114.0-00	300W	63 cfm (108m ³ /h)	1.85 x 4.68 x 5.94" (47 x 119 x 151mm)	2.0 lbs. (900g)
03115.9-00	03115.0-00	400W	63 cfm (108m ³ /h)	1.85 x 4.68 x 5.94" (47 x 119 x 151mm)	2.0 lbs. (900g)

Specifications are subject to change without notice. Suitability of this product for its intended use and any associated risks must be determined by the end customer/ buyer in its final application.