

Air Conditioners

Outdoor Air Conditioners T15, T20 and T29 Series 800-4,000 BTU/Hr.

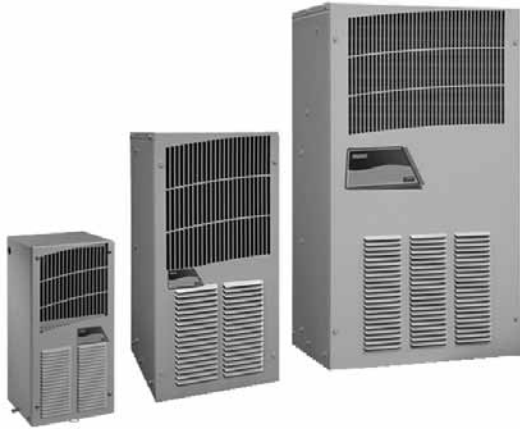

Application

Outdoor Air Conditioners provide high-efficiency positive cooling for wall-mount and stand-alone enclosures. Designed for outdoor applications requiring up to UL Type 4 rating.

Features

- Equipped with head pressure control for low ambient operation, compressor heater, coated condenser coil and thermostat
- Surface and internal recess mounting capabilities
- Equipped with a screwdriver-adjustable thermostat
- EMI/RFI noise suppressor is standard
- Reusable and washable air filter
- Broad operating range of -40 F (-40 C) to 131 F (55 C)
- All units use a CFC-free refrigerant
- Includes power cord with plug
- Built-in hanging brackets
- High performance, industrial grade and efficiency fans
- Hardware, gasket and instruction manual furnished
- Closed-loop cooling

Specifications

Galvanized steel

Finish

RAL 7035 smooth light-gray polyester powder coating

Bulletin: MCL

Industry Standards

Maintain UL/cUL Type 12, 3R or 4 rating when properly installed on a UL/cUL Type 12, 3R or 4 rated enclosure.

UL/cUL Listed; File No. SA6453

CE

Standard Product T15 Series

Catalog Number	Voltage	Hz	Phase	BTU/Hr. @ Max. Ambient Temp.	Full Load Amps	50 Hz Max. Amb. Temp (°F)	50 Hz Max. Amb. Temp (°C)	60 Hz Max. Amb. Temp (°F)	60 Hz Max. Amb. Temp (°C)	Shipping Weight (lb.)	Shipping Weight (kg)
T150116G100	100/115	50/60	1	800/800	3.8/3.6	125	52	131	55	27	12
T150126G100	220/230	50/60	1	800/900	1.4/1.5	125	52	131	55	27	21

Replacement Filter No. 10100091

Standard Product T20 Series

Catalog Number	Voltage	Hz	Phase	BTU/Hr. @ Max. Ambient Temp.	Full Load Amps	60 Hz Max. Amb. Temp (°F)	60 Hz Max. Amb. Temp (°C)	Shipping Weight (lb.)	Shipping Weight (kg)
T200216G100	115	50/60	1	1800/2000	7	131	55	56	25
T200226G100	230	50/60	1	1800/2000	3.5	131	55	56	25

Replacement Filter No. 10100090

Standard Product T29 Series

Catalog Number	Voltage	Hz	Phase	BTU/Hr. @ Max. Ambient Temp.	Full Load Amps	60 Hz Max. Amb. Temp (°F)	60 Hz Max. Amb. Temp (°C)	Shipping Weight (lb.)	Shipping Weight (kg)
T290416G100	115	50/60	1	3600/4000	13.8/13.6	131	55	107	49
T290426G100	230	50/60	1	3600/4000	6.9/6.8	131	55	107	49

Replacement Filter No. 10100093

Air Conditioners

800 BTU

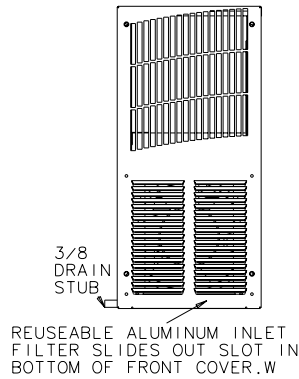

FRONT VIEW

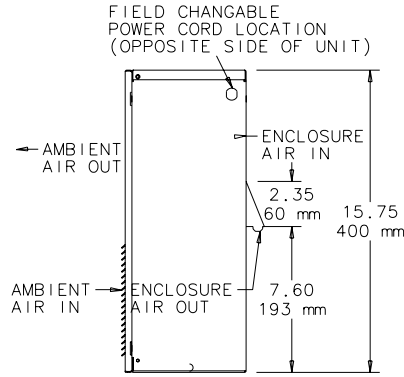

RIGHT VIEW

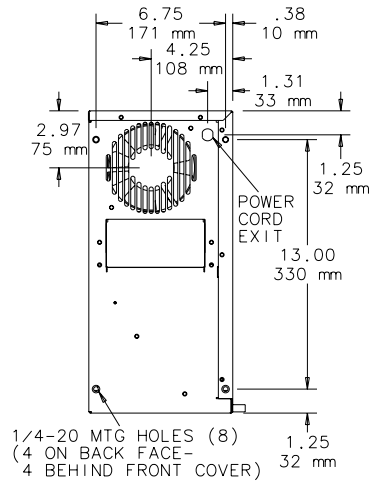

BACK VIEW

87939674

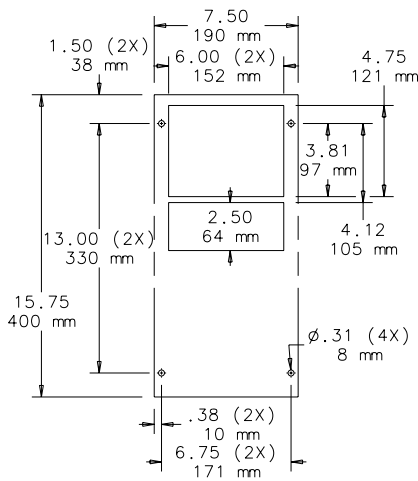

CUTOUT EXTERNAL MOUNTED

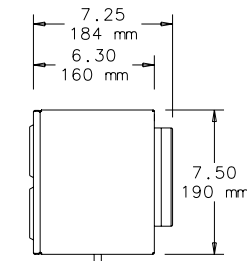

BOTTOM VIEW

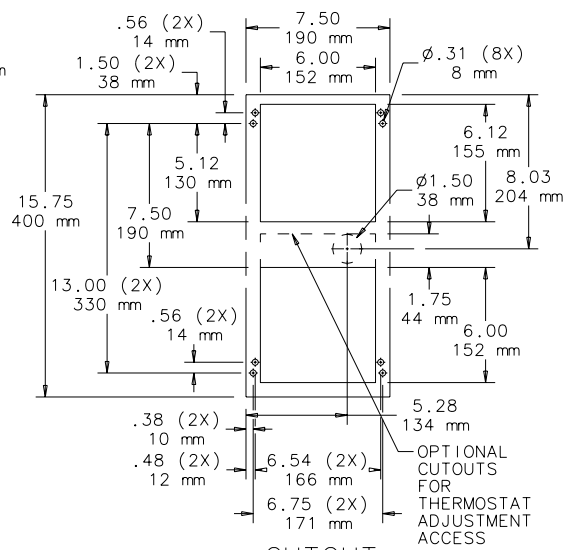

CUTOUT INTERNAL MOUNTED

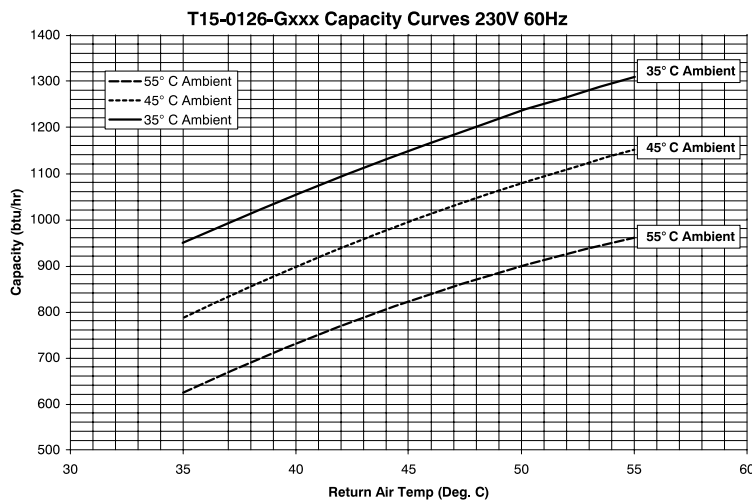

Air Conditioners

2000 BTU

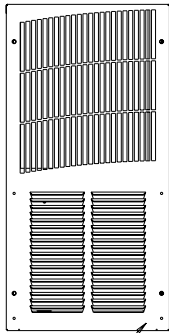

REUSEABLE ALUMINUM INLET FILTER SLIDES OUT SLOT IN BOTTOM OF FRONT COVER.

FRONT

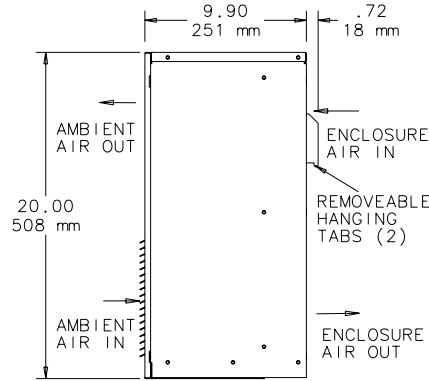

RIGHT

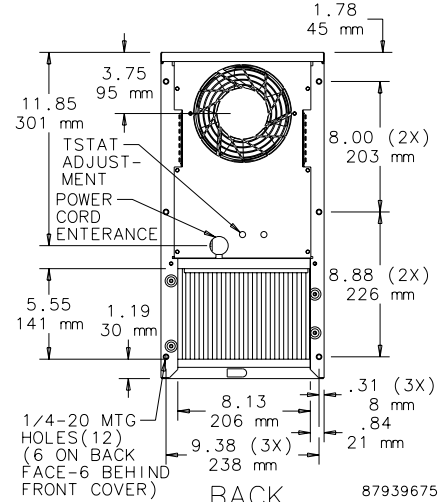

BACK

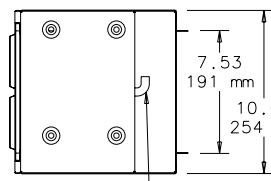

BOTTOM

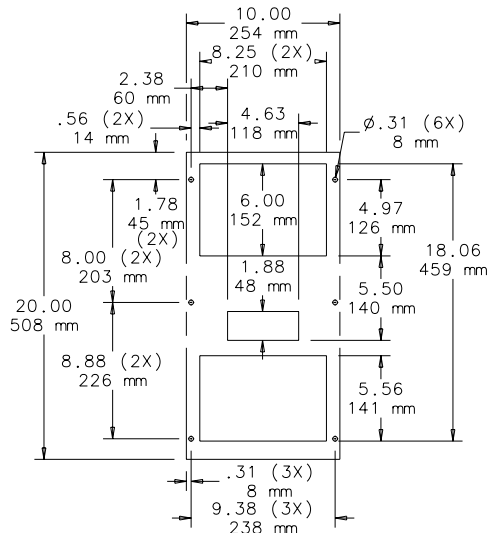

CUTOUT EXTERNAL MOUNTED

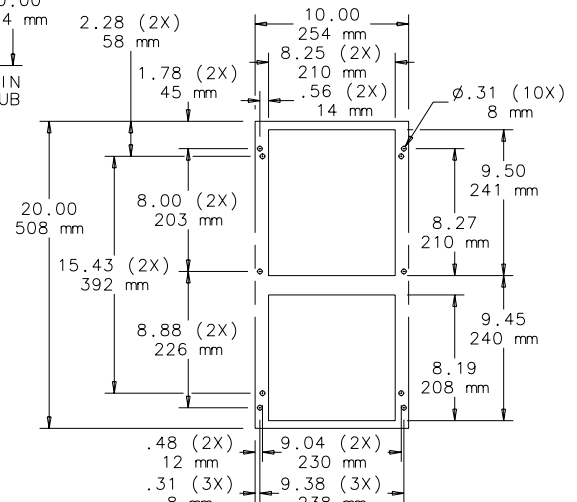

CUTOUT INTERNAL MOUNTED

T20-0216-Gxxx Capacity Curves 115V 60Hz

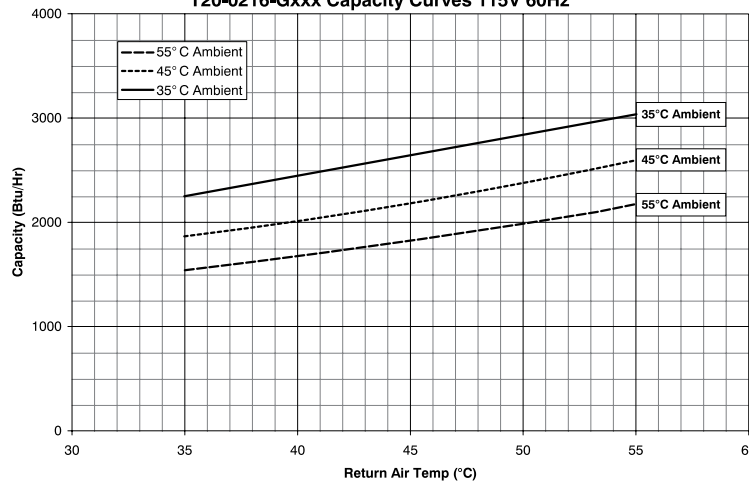

Air Conditioners

4000 BTU

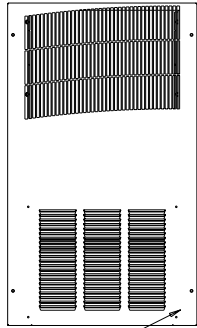

REUSEABLE ALUMINUM INLET FILTER SLIDES OUT SLOT IN BOTTOM OF FRONT COVER.

FRONT

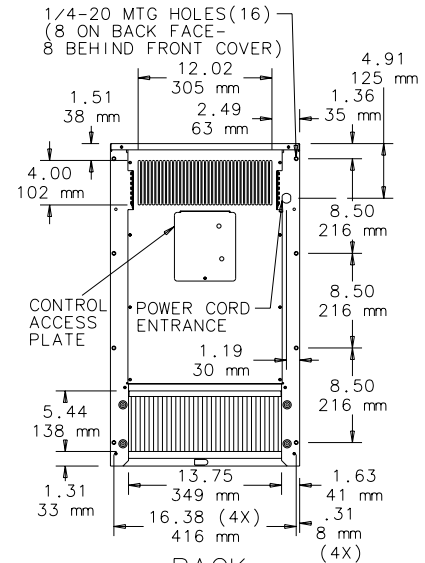
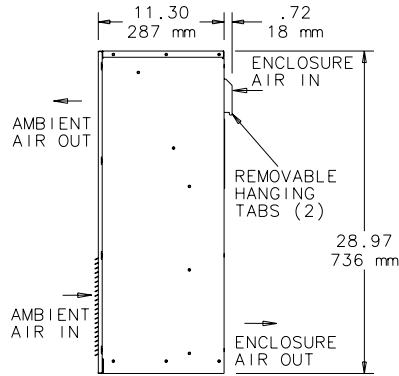

87939676

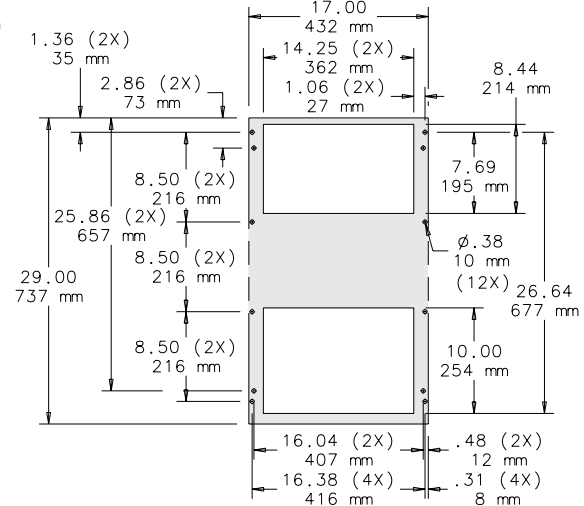
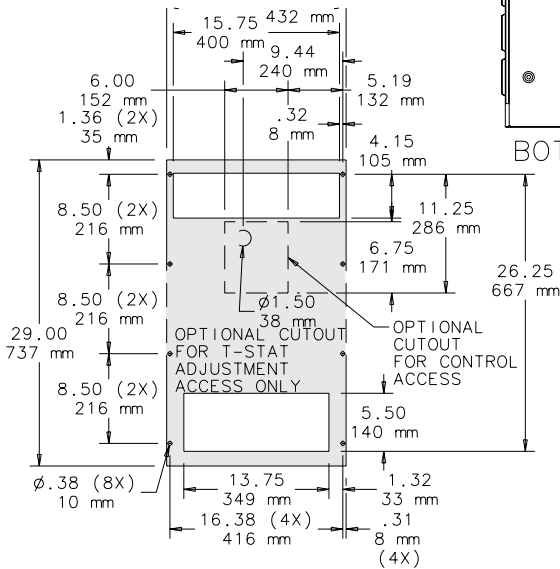
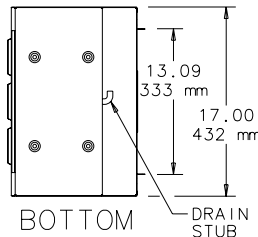

T29-04x6-Gxxx Capacity Curves, 60 Hz

