

19" Rack Accessories

Strips, Nuts & Panel Fixing Kits



Caged Nuts



Features:

A range of caged nuts suitable for fixing front panels on sub-rack systems instrument cases, etc. Available in two thread sizes, each of which is suitable for two ranges of material thickness. The steel nut is held captive in a spring steel cage. Nuts and cages are zinc-plated.

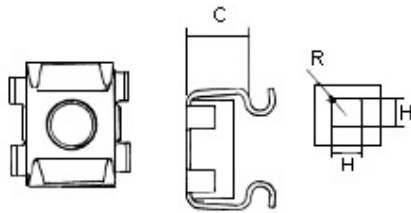

Specifications

Cage Type	Panel Range (Material Thickness)	Nut Size	H	R	C	Part Number
M5 Narrow	0.71 to 1.63 (22 to 16 s.w.g)	11.1SQ x 4.8TH	9.53	0.81	5.8	SCF008
M6 Narrow						SCF010
M5 Wide	SCF009					
M6 Wide	SCF011					

Dimensions : Millimetres



19" Rack Accessories

Strips, Nuts & Panel Fixing Kits



Rack Mounting Strip

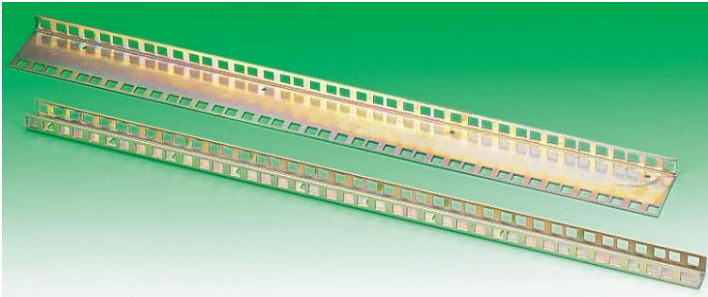

Features:

'L' and 'U' section strip with holes conforming to IEC297 made from cadmium plated mild steel and passivated for strength and long service life. Supplied in 2m (45U) lengths.

Specifications

Type	Part Number
L section	SCF001
U section	SCF002

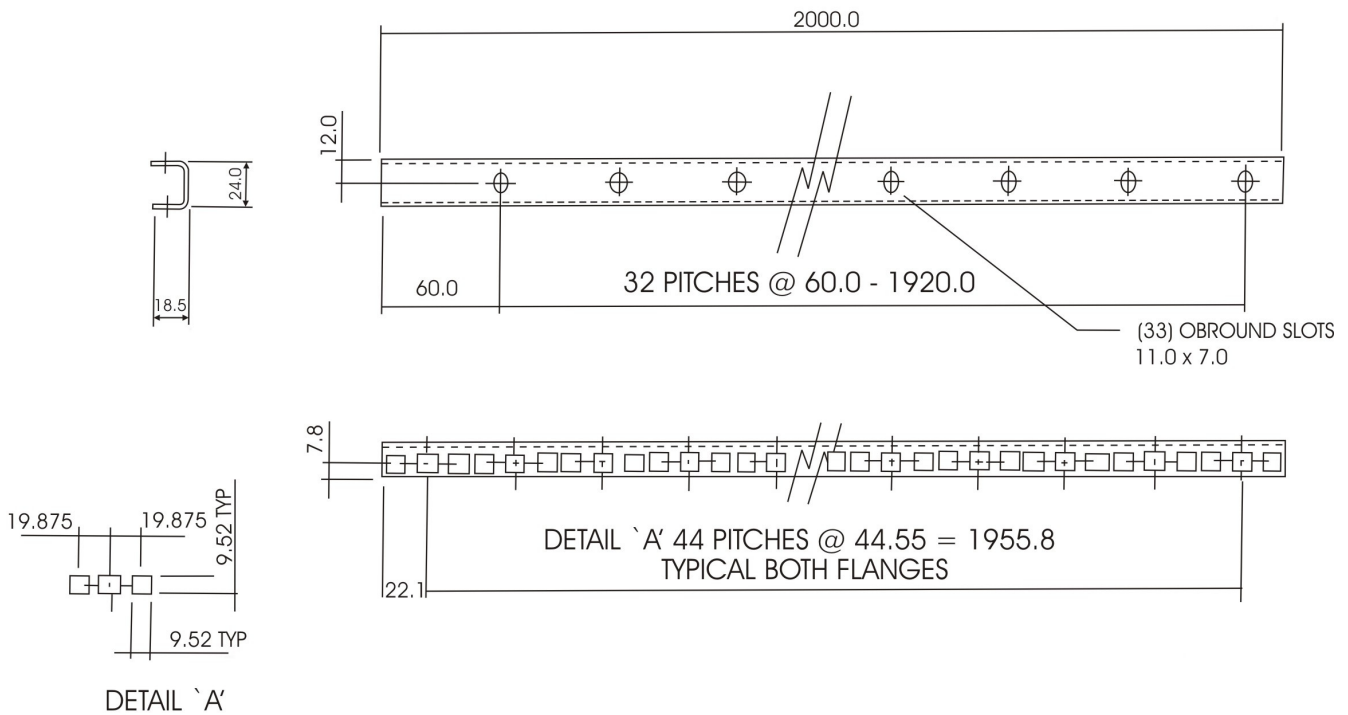

19" Rack Accessories

Strips, Nuts & Panel Fixing Kits

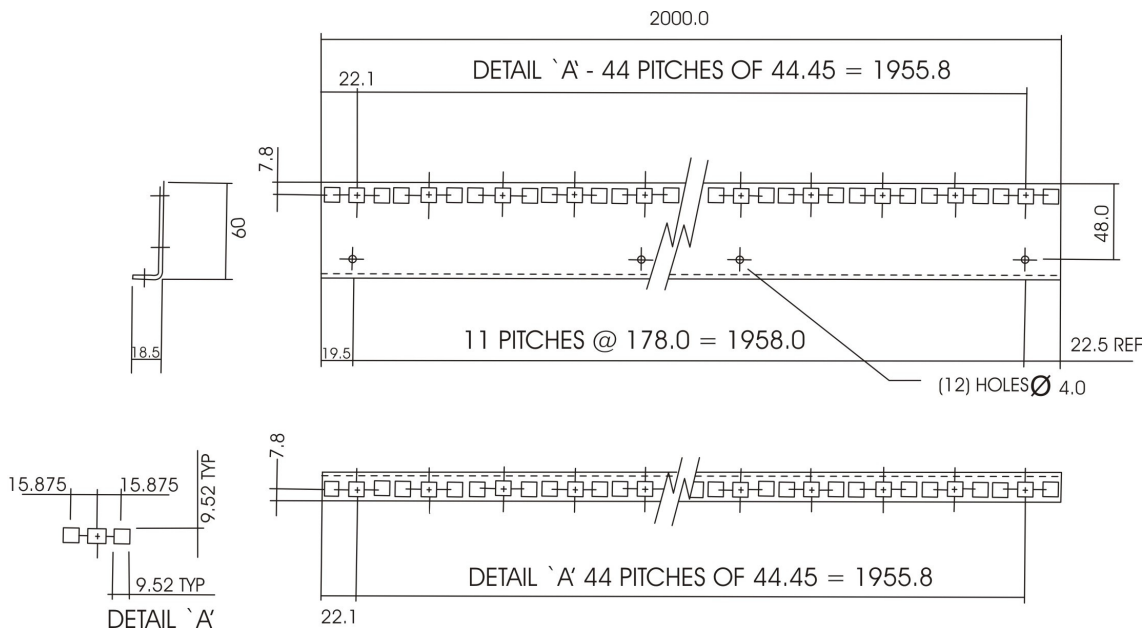

19" Rack Accessories

Strips, Nuts & Panel Fixing Kits



Notes:

International Sales Offices:

 AUSTRALIA – Farnell InOne Tel No: ++ 61 2 9645 8888 Fax No: ++ 61 2 9644 7898	 FINLAND – Farnell InOne Tel No: ++ 358 9 560 7780 Fax No: ++ 358 9 345 5411	 NETHERLANDS – Farnell InOne Tel No: ++ 31 30 241 7373 Fax No: ++ 31 30 241 7333	 SWITZERLAND – Farnell InOne Tel No: ++ 41 1 204 64 64 Fax No: ++ 41 1 204 64 54
 AUSTRIA – Farnell InOne Tel No: ++ 43 662 2180 680 Fax No: ++ 43 662 2180 670	 FRANCE – Farnell InOne Tel No: ++ 49 89 61 39 39 39 Fax No: ++ 33 474 68 99 90	 NEW ZEALAND – Farnell InOne Tel No: ++ 64 9 357 0646 Fax No: ++ 64 9 357 0656	 UK – Farnell InOne Tel No: ++ 44 8701 200 200 Fax No: ++ 44 8701 200 201
 BELGIUM – Farnell InOne Tel No: ++ 32 3 475 2810 Fax No: ++ 32 3 227 3648	 GERMANY – Farnell InOne Tel No: ++ 49 89 61 39 39 39 Fax No: ++ 49 89 613 59 01	 NORWAY – Farnell InOne Tel No: ++ 45 44 53 66 66 Fax No: ++ 45 44 53 66 02	 UK – BuckHickman InOne ++ 44 8450 510 150 ++ 44 8450 510 130
 BRAZIL – Farnell-Newark InOne Tel No: ++ 55 11 4066 9400 Fax No: ++ 55 11 4066 9410	 HONG KONG – Farnell-Newark InOne Tel No: ++ 852 2268 9888 Fax No: ++ 852 2268 9899	 PORTUGAL – Farnell InOne Tel No: ++ 34 93 475 8804 Fax No: ++ 34 93 474 5288	 UK – CPC ++ 44 8701 202 530 ++ 44 8701 202 531
 CHINA – Farnell-Newark InOne Tel No: ++86 10 6238 5152 Fax No: ++86 10 6238 5022	 IRELAND – Farnell InOne Tel No: ++ 353 1 830 9277 Fax No: ++ 353 1 830 9016	 SINGAPORE – Farnell-Newark InOne Tel No: ++ 65 6788 0200 Fax No: ++ 65 6788 0300	 EXPORT – Farnell InOne Tel No: ++ 44 8701 200 208 Fax No: ++ 44 8701 200 209
 DENMARK – Farnell InOne Tel No: ++ 45 44 53 66 44 Fax No: ++ 45 44 53 66 06	 ITALY – Farnell InOne Tel No: ++ 39 02 93 995 200 Fax No: ++ 39 02 93 995 300	 SPAIN – Farnell InOne Tel No: ++ 34 93 475 8805 Fax No: ++ 34 93 474 5107	
 ESTONIA – Farnell InOne Tel No: ++ 358 9 560 7780 Fax No: ++ 358 9 345 5411	 MALAYSIA – Farnell-Newark InOne Tel No: ++ 60 3 7873 8000 Fax No: ++ 60 3 7873 7000	 SWEDEN – Farnell InOne Tel No: ++ 46 8 730 50 00 Fax No: ++ 46 8 83 52 62	

For enquiries from all other markets

<http://www.farnellinone.com>
<http://www.buckhickmaninone.com>
<http://www.cpc.co.uk>

Disclaimer This data sheet and its contents (the "Information") belong to the Premier Farnell Group (the "Group") or are licensed to it. No licence is granted for the use of it other than for information purposes in connection with the products to which it relates. No licence of any intellectual property rights is granted. The Information is subject to change without notice and replaces all data sheets previously supplied. The Information supplied is believed to be accurate but the Group assumes no responsibility for its accuracy or completeness, any error in or omission from it or for any use made of it. Users of this data sheet should check for themselves the Information and the suitability of the products for their purpose and not make any assumptions based on information included or omitted. Liability for loss or damage resulting from any reliance on the Information or use of it (including liability resulting from negligence or where the Group was aware of the possibility of such loss or damage arising) is excluded. This will not operate to limit or restrict the Group's liability for death or personal injury resulting from its negligence. Multicomp is the registered trademark of the Group. © Premier Farnell plc 2004.

