

474-307, 474-319, 474-356

HF - Series (IP 65)

Standard models

Flexible arm 250 mm

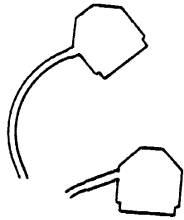

- Without joint ● 50W
- 50W
- With joint ● 50W
- 50W

Base without transformer

● 50W	12400	12600
○ 50W	12401	12601
● 50W	12410	12610
○ 50W	12411	12611

Flexible arm 500 mm

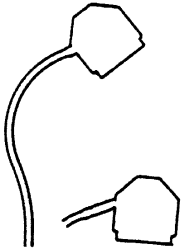

- Without joint ● 50W
- 50W
- With joint ● 50W
- 50W

● 50W	12420	12620
○ 50W	12421	12621
● 50W	12430	12630
○ 50W	12431	12631

Flexible arm 700 mm



- Without joint ● 50W
- 50W
- With joint ● 50W
- 50W

● 50W	12440	12640
○ 50W	12441	12641
● 50W	12450	12650
○ 50W	12451	12651

474-307

Jointed arm 250+400 mm

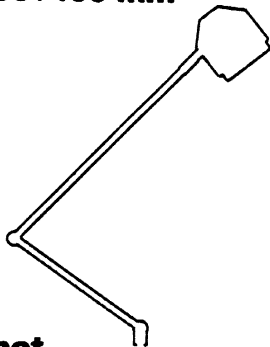

- 50W
- 50W

● 50W	12470	12670
○ 50W	12471	12671

Spot

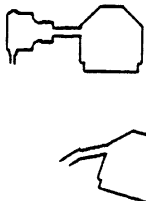

- Single joint ● 50W
- 50W
- Double joint ● 50W
- 50W

● 50W	12460	12660
○ 50W	12461	12661
● 50W	12462	12662
○ 50W	12463	12663

474-319

Accessories

Panel bracket	250 mm	●	15540
Fitted to flexible arm	500 mm	○	15541
	700 mm	●	15550
		○	15551
		●	15560
		○	15561

Trolley base	●	14024
	○	14025

Magnetic base	●	12010
---------------	---	-------

Wall bracket	●	14030
	○	14031

Screw-clamp bracket	●	14020
	○	14021

Dimmer		
Fitted in base		
AC/DC, 12/24V, 20-35W		14081

Switch		
Fitted to lamp head		12095

Handle		
Fitted to lamp head		12096

Protective transformer		
IP-23	230V/12V- 80VA	12030
IP-23	230V/24V- 80VA	12035

Distributor insert x 3		
For 12030/12035		12040

Plug-in-transformer		
IP-20	230V/11,5V- 50VA	12045
IP-20	230V/24V- 50VA	12050

For lenses, bulbs, reflectors and moisture/dust seal, see spare-part list pp. 10 - 12

● = Standard colour black
○ = Standard colour white



- Series

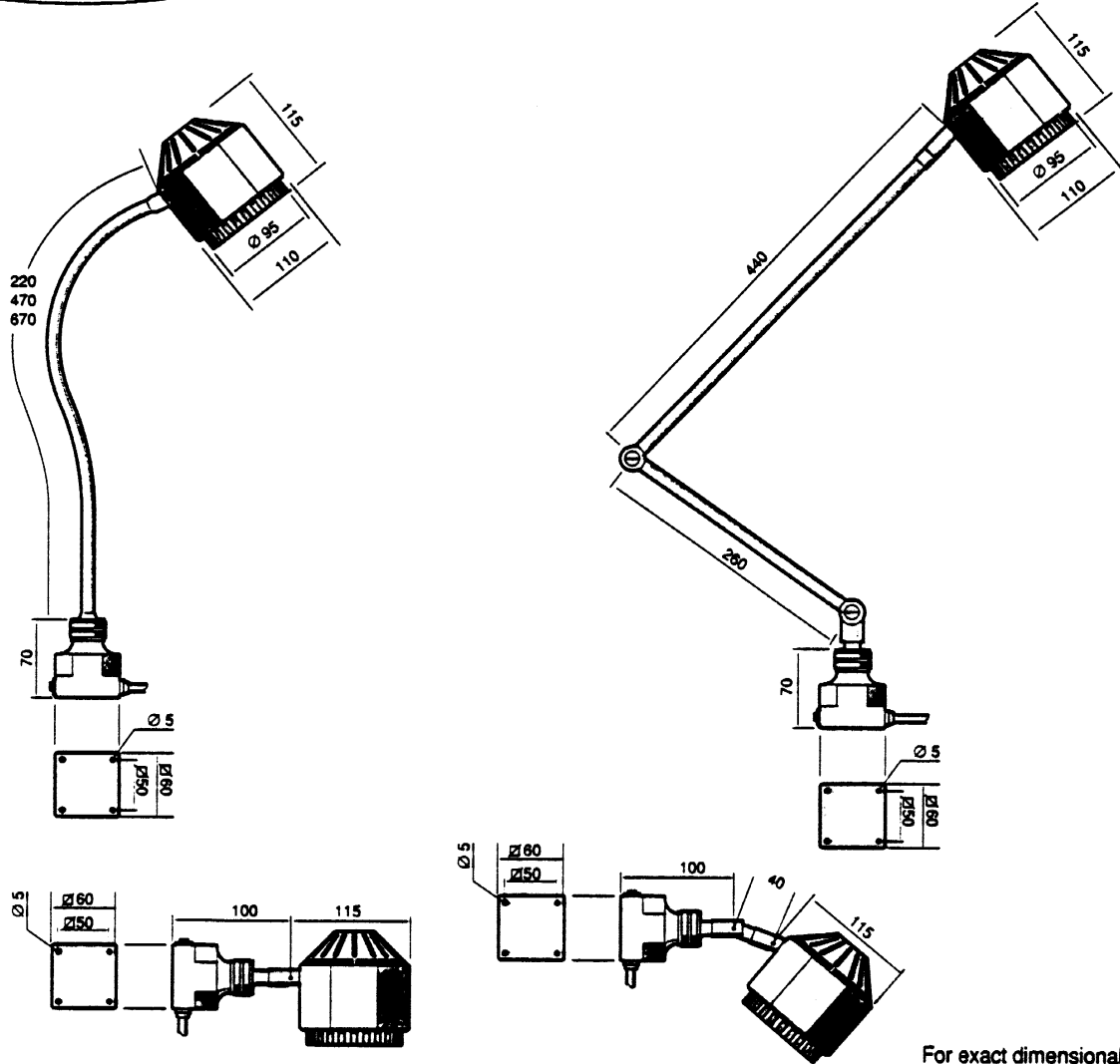
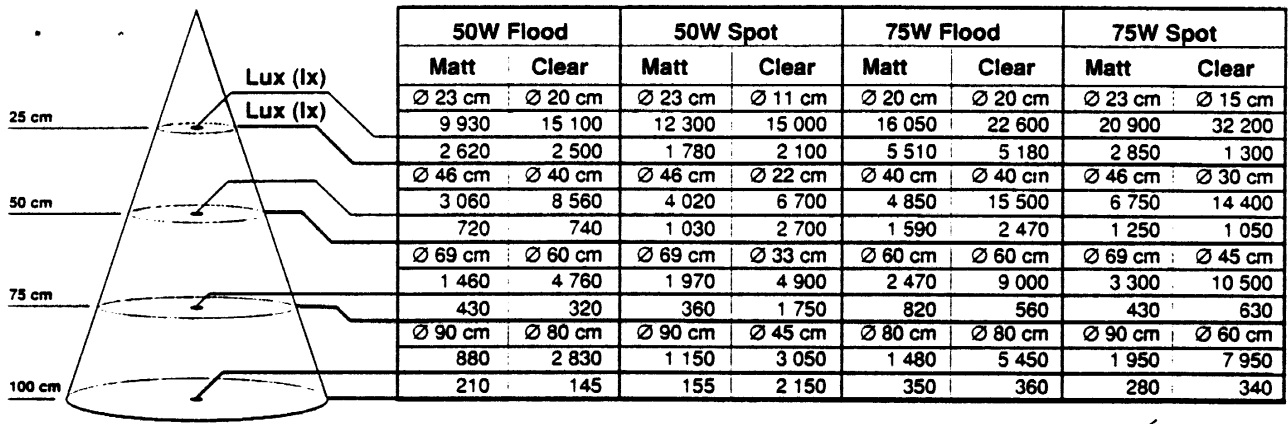

For exact dimensional data contact Sunnex.

Trolley base

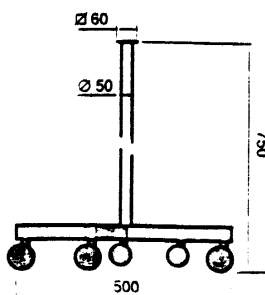

Magnetic base

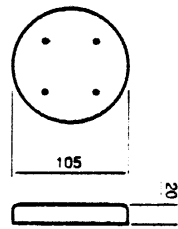

Screw-clamp bracket

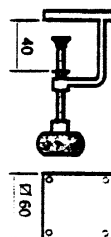

Wall bracket

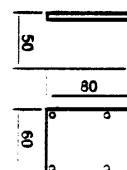

Panel mounting

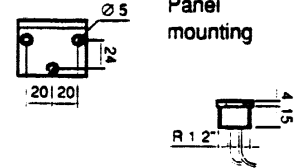

HS - series

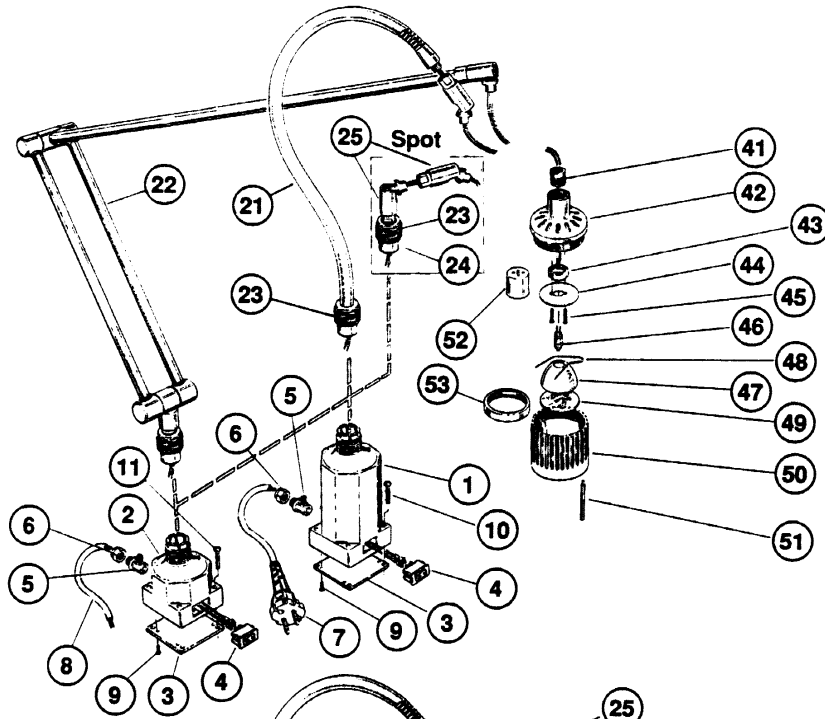

HF- series

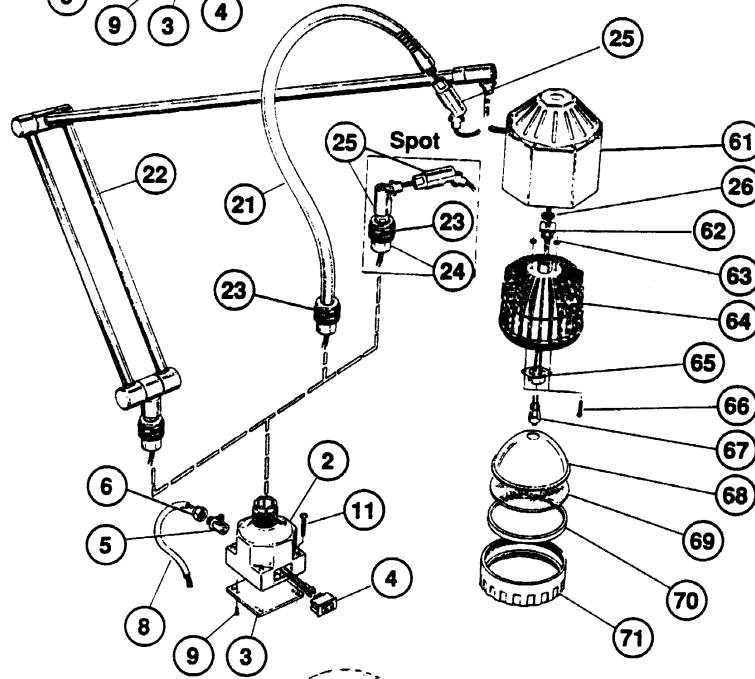

CL- series

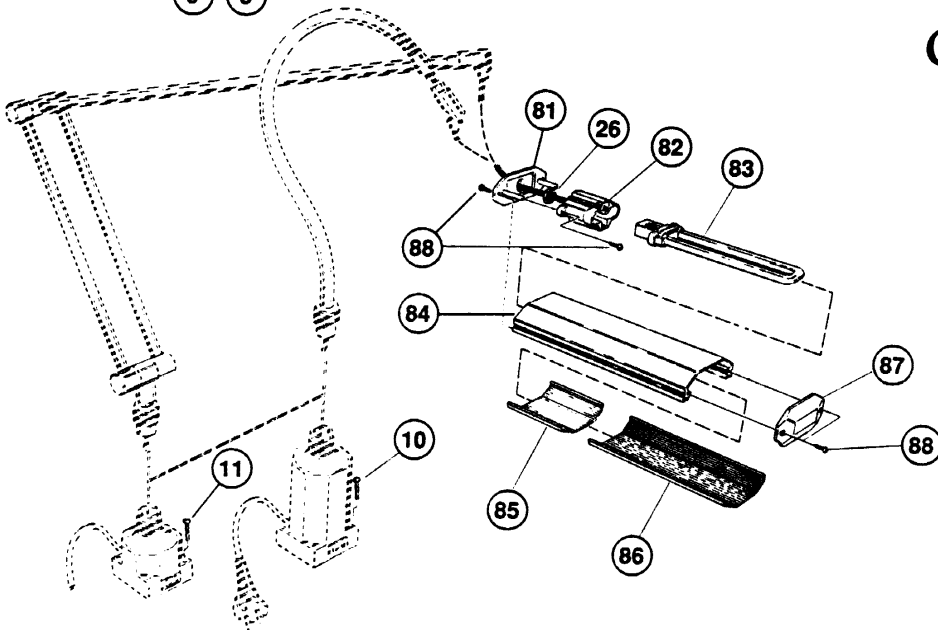

Item	Colour	Description	Qty	HS		HF	CL
Base parts							
1	●	Base with transformer 117/12 V	1	15328			
	○	Base with transformer 117/12 V	1	15329			
	●	Base with transformer 230-240/12V	1	15320			
	○	Base with transformer 230-240/12V	1	15321			
2	●	Base without transformer	1	15340	15340	15340	
	○	Base without transformer	1	15341	15341	15341	
3		Bedplate	1	15385	15385	15385	
4		Switch	1	15355	15355	15355	
5		Cord saver	1	15360	15360	15360	
6		Nut for cord saver	1	15361	15361	15361	
7		Power cord with moulded plug	1	15878			
8		Power cord without plug, 2 m, 2x0.75mm ²	1		15376	15376	
9		Screw FXS B4x9.5	4	15390	15390	15390	
10		Screw Ø9 M4x23 mm	4	15395			15395
11		Screw Ø9 M4x25 mm	4		15396	15396	15396
Arm parts							
21	●	Flexible arm, 250 mm	1	15500	15500	15500	
	○	Flexible arm, 250 mm	1	15501	15501	15501	
	●	Flexible arm, 500 mm	1	15510	15510	15510	
	○	Flexible arm, 500 mm	1	15511	15511	15511	
	●	Flexible arm, 700 mm	1	15520	15520	15520	
	○	Flexible arm, 700 mm	1	15521	15521	15521	
22	●	Jointed arm, 250+400 mm	1	15580	15580	15580	
	○	Jointed arm, 250+400 mm	1	15581	15581	15581	
23	●	Clamping nut	1	15305	15305	15305	
	○	Clamping nut	1	15306	15306	15306	
24		Stub, hexagonal	1	15242	15242	15242	
25	●	Combination joint, single spot joint, OMI 287	1	15212	15212	15212	
	○	Combination joint, single spot joint, OMI 287	1	15213	15213	15213	
	●	Combination joint, double spot joint, OMI 287	2	15212	15212	15212	
	○	Combination joint, double spot joint, OMI 287	2	15213	15213	15213	
26		Nut	1			15836	15836
HS-series							
41		Threated thimble	1	15210	15210		
42	●	Lamp head	1	15200	15200		
	○	Lamp head	1	15201	15201		
43		Lamp holder with 680 mm lead	1	15160	15160		
		Lamp holder with 880 mm lead	1	15161	15161		
44		Shield disk, 12V	1	15155	15155		
		Shield disk, 24V	1		15156		
45		Screw, RXS B4x16	2	15150	15150		
46		Bulb, 12V, 5W	1	15142	15142		
		Bulb, 12V, 10W	1	15145	15145		
		Bulb, 12V, 20W	1	15140	15140		
		Bulb, 24V, 10W	1	15144	15144		
		Bulb, 24V, 20W	1	15141	15141		
		Cold-light reflector, 12V, 20W, 10° beam	1	15124	15124		
		Cold-light reflector, 12V, 20W, 20° beam	1	15125	15125		
		Cold-light reflector, 12V, 20W, 30° beam	1	15126	15126		
47		Reflector, superspot	1	15120	15120		
		Reflector, spot	1	15121	15121		
		Reflector, flood	1	15123	15123		
48		Thrust spring	1	15130	15130		
49		Lens, clear	1	15110	15110		
		Lens, matt	1	15112	15112		
		Lens, red	1	15114	15114		
		Lens, opal	1	15113	15113		
50	●	Lampshade	1	15100	15100		
	○	Lampshade	1	15101	15101		
51	●	Spacer pin	1	15108			
	○	Spacer pin	1	15109			
52		Moisture and dust seal, silicone	1	15154	15154		
53		Moisture and dust seal, silicone	1	15153	15153		

● = Standard colour black

○ = Standard colour white

Item	Colour	Description	Qty	HS		HF	CL
				117V 12V 230V 12V	1222AV	1222AV	122V 230V
HF-series							
61	●	Lamp head	1			13800	
	○	Lamp head	1			13801	
62		Expanding cable grommet	1			13775	
63		O-ring	2			13817	
64		Heat shield	1			13815	
65		Lamp holder with 700mm led	1			13840	
		Lamp holder with 900mm led	1			13841	
66		Screw, PT-KA 3.0x14	2			15858	
67		Bulb, 12V, 35W	1			13830	
		Bulb, 12V, 50W	1			13831	
		Bulb, 12V, 75W	1			13832	
		Bulb, 12V, 100W	1			13833	
		Bulb, 24V, 50W	1			13834	
		Bulb, 24V, 75W	1			13835	
		Bulb, 24V, 100W	1			13836	
		Cold-light reflector, 12V, 20-75W, 8-38° beam	1			*	
		Cold-light reflector with safety glass, 12V, 20-75W, 8-60° beam	1			*	
68		Reflector, spot	1			13820	
		Reflector, flood	1			13821	
69		Lens, clear	1			13825	
		Lens, matt	1			13826	
70		Silicone seal	1			13816	
71	●	Lens holder	1			13810	
	○	Lens holder	1			13811	
CL-series							
81	●	Inner end-piece	1				15850
	○	Inner end-piece	1				15851
82		Lamp holder	1				15883
83		Fluorescent tube, 7W	1				15880
		Fluorescent tube, 9W	1				15881
		Fluorescent tube, 11W	1				15882
84	●	Reflector, 7-9W	1				15810
	○	Reflector, 7-9W	1				15811
	●	Reflector, 11W	1				15820
	○	Reflector, 11W	1				15821
85	●	Cover section, 7-9 and 11W	1				15830
	○	Cover section, 7-9 and 11W	1				15831
86		Fluted lens, 7-9W	1				15861
		Fluted lens, 11W	1				15862
87	●	Outer end-piece	1				15840
	○	Outer end-piece	1				15841
88		Screw, PT-KA 3.0x14	6				15858

- = Standard colour black
○ = Standard colour white

* = Ask for quotation

Please contact Sunnex for further information or to enquire about products not listed here.



A member of the Nolato group

Sunnex Equipment AB
Box 116, S-686 23 Sunne, Sweden
Tel +46-565 119 20, Fax +46-565 133 63



ALLENEX HOUSE THE FIRS
AYLESBURY ROAD BIERTON
BUCKS ENGLAND HP22 5DX

☎ (0296) 24834/89357 FAX (0296) 393413