

Heat Sink Cases

Accessories

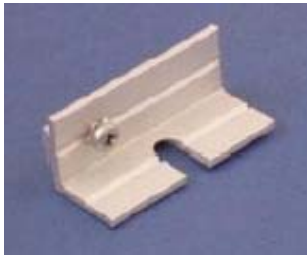

Linc-Lug

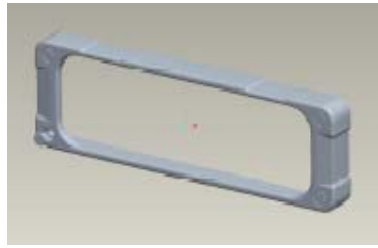

Bezels



Gaskets

Features:

Linc-Lugs:

- Aluminium extruded mounting bracket for fixing E-Case housings to walls, panels, vehicle bulkheads etc.
- Linc-Lug slides into any external dovetail feature on E-Case housings and is retained by the end plates.
- The silver lugs are strip silver anodized and are used with the silver E-Case enclosures that are anodized in the same way.

Non-Standard Lengths: Available but not with U-shaped slot.

Material: Aluminium 6063 T6 (HE9).

Finish: Silver anodized 5µm thickness. (Cut ends and inside of U-shaped slot are not anodized).

Weight: 15g. (Pair of lugs in plastic bag - MCLPS40).

Extrusion perimeter: 70mm.

Application Information: Linc-Lug is secured as follows:

For cases length 40mm and 80mm, use Linc-Lugs of appropriate length, retain with the end plates. Drill a hole 2.6mm diameter through the dovetail on the Linc-Lug the V-groove as a drill start. Slide the drilled lug to the desired position along enclosure. Drive a No.4 x 1/4" posi-pan type-B self tapping screw into the drilled hole to security wedge the Linc-Lug in the dovetail slot. MCLPS40 lugs are now available with screws pre-fitted. These are supplied as a pair in a plastic bag.

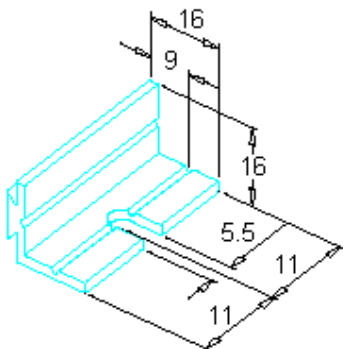

Bezels:

- Cosmetic end plate surrounds made of ABS plastic that are available in four sizes to suit the four extrusion profiles.
- The four end-plate mounting screws pass through the bezel, through the end-plate and into the extrusion.
- The screw heads are concealed by inserts which closely match the bezel.
- This gives a much-improved cosmetic appearance.

Application Information:

The bezels come with the four inserts attached to a sprue on the bezel. The sprue should be cut off the bezel using a sharp knife. Similarly the inserts should be cut off the sprue. Care should be taken not to leave plastic pipes on the inserts that will prevent them lying flush when later inserted in the bezel. Once inserted, the inserts are not intended to be removed, but actually it is possible to remove them without damage by carefully using a pin.

Bezels have a few applications that are worth particular mention. It is usual to put script on the front plate of an electronics housing. This can be done by screen printing the plates, but an alternative method is to reverse print the back side of a clear polycarbonate sheet. This can be cut and stuck on the end plate. The bezel is used to conceal the cut edges. Another application of the bezels is to conceal the edge of a gasket that would normally be visible sandwiched between the end plate and the extrusion.



Gaskets:

- Gaskets come as a set suitable for waterproofing one enclosure.
- A set comprises two white silicon foam gaskets and a number of polythene washers.
- The washers are optionally fitted under the heads of the screws and raise the rating of the gasket set from IP65 to IP66.

Application Information:

The E-Case range was not originally designed to be waterproof. Even with a gasket seal around the edge of the profile water could enter under the heads of the screws and enter the enclosure through the open screw port. The original waterproof enclosure range was the Linc-Ace range which had drilled 'blind' holes for the screws. Even if these holes filled with water, it did not enter the main part of the enclosure. Linc-Ace was a heavy extrusion, costly to manufacture and is now obsolete.

Use of a flat gasket will render the enclosure 'waterproof' to IP65 and addition of a washer under each screw will give an increased rating of IP66. Use of these gaskets will not reliably give a rating of IP67.

A die-cast aluminium enclosure with a rating of IP67 was put under 1 metre of water for 24 hours with no water ingress

An E-Case enclosure with a rating of IP66 was put under 1 metre of water for 24 hours and it contained a few drops of water (say 0.1ml).

An E-Case enclosure with a rating of IP65 when put under water took a few minutes to fill up.

These results, which have been found in practice, probably exceed the strict requirements of the IP rating, but this gives a margin of confidence. The die-cast enclosure is better than an E-Case enclosure because one half of the sealing surface (metal to rubber) is a smooth (die-cast) metal ridge whereas on an extrusion it is a cut face. It has small saw cut marks on the sealing surface which will not be completely filled by the gasket thus forming small channels from the outside to the inside of the box. Normally, surface tension will prevent water flowing down these channels, but under pressure water might flow. In order to get round this one might consider a liquid gasket compound painted on to the end of the extrusion. This will also help align the gasket on the extrusion prior to fitting the end plate.

Another feature of the flat gasket is that it needs to be fitted with some care-it has offset holes and needs orienting like the end plate. Also, failure to completely screw down one screw will reduce the IP rating and this will not be obvious when inspected. On the other hand a die-cast enclosure is fool proof. However, it is very ugly, and all the holes for the connectors have to be individually machined, whereas end plates can be mass-produced, complete with connector holes, by using a CNC punch.

It should be noted that if a bezel is to be used then the four washers can be omitted from under the screw heads. The plastic of the bezel gets squeezed under the screw heads and makes a seal. The benefit of the bezel is that it conceals the gasket in applications where appearance is important.

Part Number Table

Description	Part Number
Bezel, Black, For MCREAS Cases	MCZAB1
Bezel, Black, For MCREBS Cases	MCZBB1
Bezel, Black, For MCRECS Cases	MCZCB1
Bezel, Black, For MCREDS Cases	MCZDB1
Gasket Set, IP65, For MCREAS Cases	MCGEA1
Gasket Set, IP65, For MCREBS Cases	MCGEB1
Gasket Set, IP65, For MCRECS Cases	MCGEC1
Gasket Set, IP65, For MCREDS Cases	MCGED1
Linc Lug, 40mm, Pack 2	MCLPS40
Linc Lug, 80mm, Pack 2	MCLPS80

Heat Sink Cases Accessories



Notes:

International Sales Offices:

 AUSTRALIA - Farnell Tel No: ++61 1300 361 005 Fax No: ++61 1300 361 225	 FINLAND - Farnell Tel No: ++358 9 560 7780 Fax No: ++358 9 345 5411	 ITALY - Farnell Tel No: ++39 02 93 995 200 Fax No: ++39 02 93 995 300	 SPAIN - Farnell Tel No: 901 20 20 80 Fax No: 901 20 20 90
 AUSTRIA - Farnell Tel No: ++43 662 2180 680 Fax No: ++43 662 2180 670	 FRANCE - Farnell Tel No: ++33 474 68 99 99 Fax No: ++33 474 68 99 90	 MALAYSIA - Farnell-Newark Tel No: ++60 3 7873 8000 Fax No: ++60 3 7873 7000	 SWEDEN - Farnell Tel No: ++46 8 730 50 00 Fax No: ++46 8 83 52 62
 BELGIUM - Farnell Tel No: ++32 3 475 2810 Fax No: ++32 3 227 3648	 GERMANY - Farnell Tel No: ++49 89 61 39 39 39 Fax No: ++49 89 613 59 01	 NETHERLANDS - Farnell Tel No: ++31 30 241 7373 Fax No: ++31 30 241 7333	 SWITZERLAND - Farnell Tel No: ++44 204 64 64 Fax No: ++44 204 64 54
 BRAZIL - Farnell-Newark Tel No: ++55 11 4066 9400 Fax No: ++55 11 4066 9410	 HONG KONG - Farnell-Newark Tel No: ++852 2268 9888 Fax No: ++852 2268 9899	 NEW ZEALAND - Farnell Tel No: 0800 90 80 80 Fax No: 0800 90 80 81	 UK - Farnell Tel No: ++44 8701 200 200 Fax No: ++44 8701 200 201
 CHINA - Farnell-Newark Tel No: ++86 10 6238 5152 Fax No: ++86 10 6238 5022	 HUNGARY - Farnell Tel No: ++44 870 1200 208 Fax No: ++44 870 1200 209	 NORWAY - Farnell Tel No: 800 146 70 Fax No: 800 146 76	 UK - CPC ++44 8701 202 530 ++44 8701 202 531
 CZECH REPUBLIC - Farnell Tel No: ++44 870 1200 208 Fax No: ++44 870 1200 209	 INDIA - Farnell Tel No: ++44 870 1200 208 Fax No: ++44 870 1200 209	 PORTUGAL - Farnell Tel No: ++34 93 475 8804 Fax No: ++34 93 474 5288	 USA - Newark Tel No: 800 463 9275
 DENMARK - Farnell Tel No: ++45 44 53 66 44 Fax No: ++45 44 53 66 06	 IRELAND - Farnell Tel No: ++353 1 830 9277 Fax No: ++353 1 830 9016	 RUSSIA - Farnell Tel No: ++44 870 1200 208 Fax No: ++44 870 1200 209	 EXPORT - Farnell Tel No: ++44 8701 200 208 Fax No: ++44 8701 200 209 For enquiries from all other markets
 ESTONIA - Farnell Tel No: ++358 9 560 7780 Fax No: ++358 9 345 5411	 ISRAEL - Farnell Tel No: ++180 937 0015 Fax No: ++180 937 0014	 SINGAPORE - Farnell-Newark Tel No: ++65 6788 0200 Fax No: ++65 6788 0300	http://www.farnell.com http://www.newark.com http://www.cpc.co.uk

Disclaimer This data sheet and its contents (the "Information") belong to the Premier Farnell Group (the "Group") or are licensed to it. No licence is granted for the use of it other than for information purposes in connection with the products to which it relates. No licence of any intellectual property rights is granted. The Information is subject to change without notice and replaces all data sheets previously supplied. The Information supplied is believed to be accurate but the Group assumes no responsibility for its accuracy or completeness, any error in or omission from it or for any use made of it. Users of this data sheet should check for themselves the Information and the suitability of the products for their purpose and not make any assumptions based on information included or omitted. Liability for loss or damage resulting from any reliance on the Information or use of it (including liability resulting from negligence or where the Group was aware of the possibility of such loss or damage arising) is excluded. This will not operate to limit or restrict the Group's liability for death or personal injury resulting from its negligence. SPC Multicomp is the registered trademark of the Group. © Premier Farnell plc 2008.

