

## Pedestals and Pedestal Accessories

### Pedestals



Pedestals enable many types of enclosures and boxes to be floor mounted. Four columns and two bases are available. Columns can be mounted on either base, through the vertical column or directly to the enclosure. A cutout must be made in the enclosure if the wires are to come through the column.

Columns have flanges at each end and a gasketed access plate. Screws, oil-resistant gaskets and box connector fitting are furnished with each column for joining an enclosure to the top of the column. Columns are 14 gauge steel with 10 gauge flanges. 18.00 x 18.00-in. (457 x 457-mm) base is .19-in. (5-mm) steel and 24.00 x 24.00-in. (610 x 610-mm) base is .25-in. (6-mm) steel. Both bases have leveling screws and holes for bolting to the floor. Finish on bases and columns is ANSI 61 gray polyester powder coating over pretreated surfaces. Bases and columns must be ordered separately.

The user would normally remove the mounting brackets from the enclosure if the enclosure is mounted on a pedestal. Hoffman can supply enclosures without mounting brackets and with cutouts. Consult factory for more information.

Bulletin: P1

Catalog Number	AxBxC mm/in.	Description	C mm/in.	D mm/in.	F mm/in.	H mm/in.	M mm/in.	N mm/in.	P mm/in.	S mm/in.	T mm/in.
A44CCOL	889 x 102 x 102 35.00 x 4.00 x 4.00	Straight Pedestal Column	—	95	70	—	184	152	—	—	—
A44PBCOL	1041 x 102 x 102 41.00 x 4.00 x 4.00	Angled Pedestal Column	—	95	70	—	184	152	—	70	52
A66CCOL	889 x 152 x 152 35.00 x 6.00 x 6.00	Straight Pedestal Column	—	146	121	—	203	171	—	—	—
A66PBCOL	1041 x 152 x 152 41.00 x 6.00 x 6.00	Angled Pedestal Column	—	146	121	—	203	171	—	73	28
A18SBASE	457 x 457 18.00 x 18.00	Pedestal Base	457	—	—	25	—	—	16	—	—
A24SBASE	610 x 610 24.00 x 24.00	Pedestal Base	610	—	—	28	—	—	17	—	—

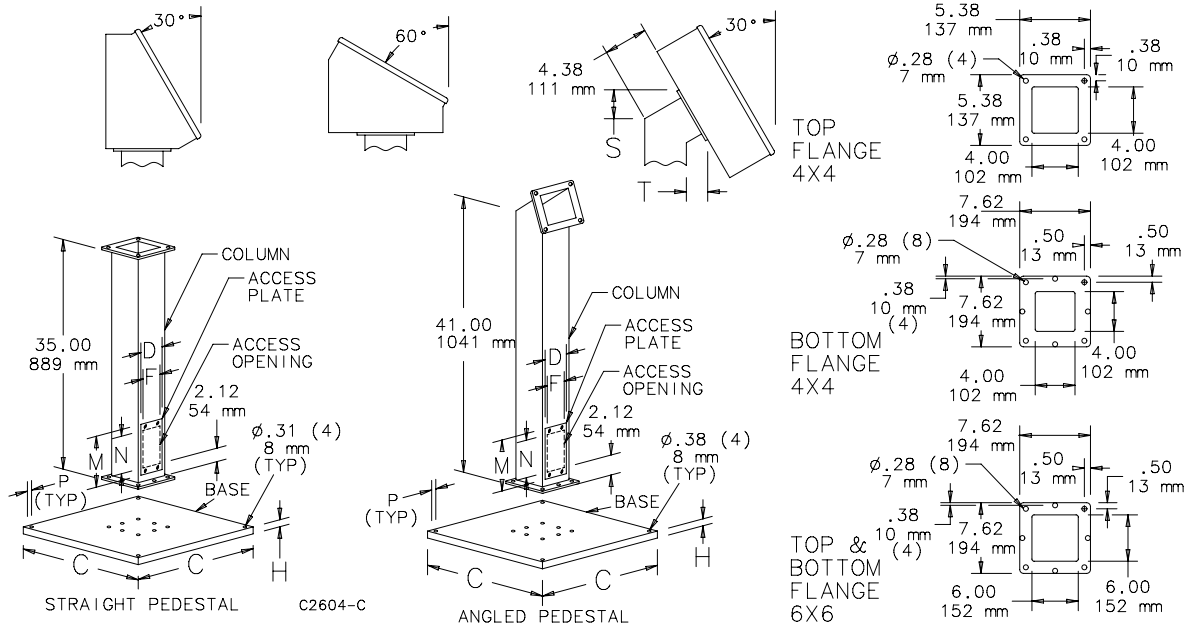

## Pedestals and Pedestal Accessories

### Pedestal with Legs



Pedestal is available in two heights. Vertical tube has rigid one-piece construction. Bottom of tube is open. Four sturdy, die-cast legs bolt to vertical tube. Legs have holes for bolting pedestal to the floor. Legs will accept casters in limited applications. Heavy-duty black polymer caps fit on ends of legs to cover bolts or levelers. Pedestal has ANSI 61 medium-gray or RAL 7035 textured light-gray polyester powder paint finish. Tapped mounting holes in the top of pedestal allow attachment to HMI base with cutout, swivel, swivel tilt or angle adapter. Hardware and gasket to attach enclosure are included.

- Use 4.00 x 4.00-in. (102 x 102-mm) pedestal with CONCEPT® HMI and INLINE® HMI Enclosures
- Use 8.00 x 8.00-in. (203 x 203-mm) pedestal with PROLINE® Sloped-Front Enclosures

Bulletin: P1

Catalog Number	AxBxC mm/in.	Finish	Description	D mm/in.
AP26L44	660 x 102 x 102 26.00 x 4.00 x 4.00	ANSI 61	Steel	600 23.62
AP26L44LG	660 x 102 x 102 26.00 x 4.00 x 4.00	RAL 7035	Steel	600 23.62
AP36L44	914 x 102 x 102 36.00 x 4.00 x 4.00	ANSI 61	Steel	600 23.62
AP36L44LG	914 x 102 x 102 36.00 x 4.00 x 4.00	RAL 7035	Steel	600 23.62
AP26L88	660 x 203 x 203 26.00 x 8.00 x 8.00	ANSI 61	Steel	702 27.62
AP26L88LG	660 x 203 x 203 26.00 x 8.00 x 8.00	RAL 7035	Steel	702 27.62
AP36L88	914 x 203 x 203 36.00 x 8.00 x 8.00	ANSI 61	Steel	702 27.62
AP36L88LG	914 x 203 x 203 36.00 x 8.00 x 8.00	RAL 7035	Steel	702 27.62

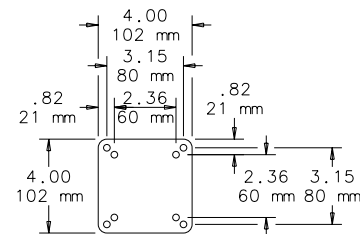
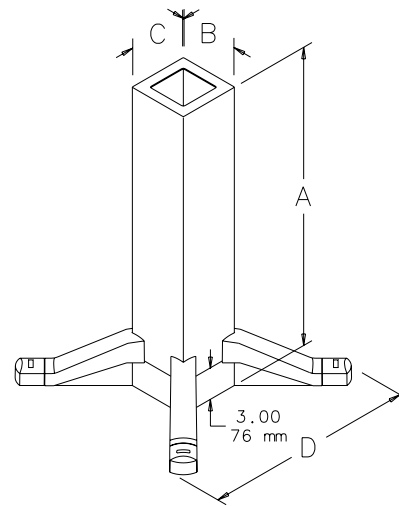

TOP FLANGE 4X4

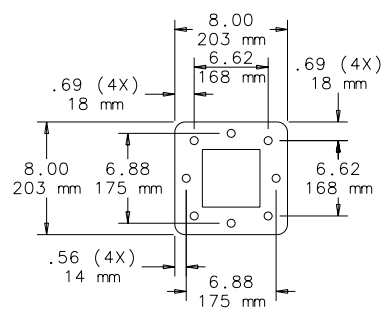

TOP FLANGE 8X8

87799590

## Pedestals and Pedestal Accessories

### Bolt-Down Pedestal



Bolt-Down Pedestal is available in two heights. The vertical tube has rigid one-piece construction. Rigid cast aluminum base flanges bolt to the vertical tube. Pedestal has ANSI 61 medium-gray or RAL 7035 textured light-gray polyester powder paint finish. Tapped mounting holes in the top of pedestal allow attachment to operator interface base with cutout, swivel, swivel tilt or angle adapter. Hardware and gasket to attach enclosure are included.

- Use 4.00 x 4.00-in. (102 x 102-mm) pedestal with CONCEPT® HMI and INLINE® HMI Enclosures
- Use 8.00 x 8.00-in. (203 x 203-mm) pedestal with PROLINE® Sloped-Front Enclosures

Bulletin: P1

Catalog Number	AxBxC mm/in.	Finish	Description	D mm/in.	E mm/in.
AP23B44	584 x 102 x 102 23.00 x 4.00 x 4.00	ANSI 61	Steel	159 6.26	133 5.25
AP23B44LG	584 x 102 x 102 23.00 x 4.00 x 4.00	RAL 7035	Steel	159 6.26	133 5.25
AP33B44	838 x 102 x 102 33.00 x 4.00 x 4.00	ANSI 61	Steel	159 6.26	133 5.25
AP33B44LG	838 x 102 x 102 33.00 x 4.00 x 4.00	RAL 7035	Steel	159 6.26	133 5.25
AP23B88	584 x 203 x 203 23.00 x 8.00 x 8.00	ANSI 61	Steel	260 10.25	235 9.25
AP23B88LG	584 x 203 x 203 23.00 x 8.00 x 8.00	RAL 7035	Steel	260 10.25	235 9.25
AP33B88	838 x 203 x 203 33.00 x 8.00 x 8.00	ANSI 61	Steel	260 10.25	235 9.25
AP33B88LG	838 x 203 x 203 33.00 x 8.00 x 8.00	RAL 7035	Steel	260 10.25	235 9.25

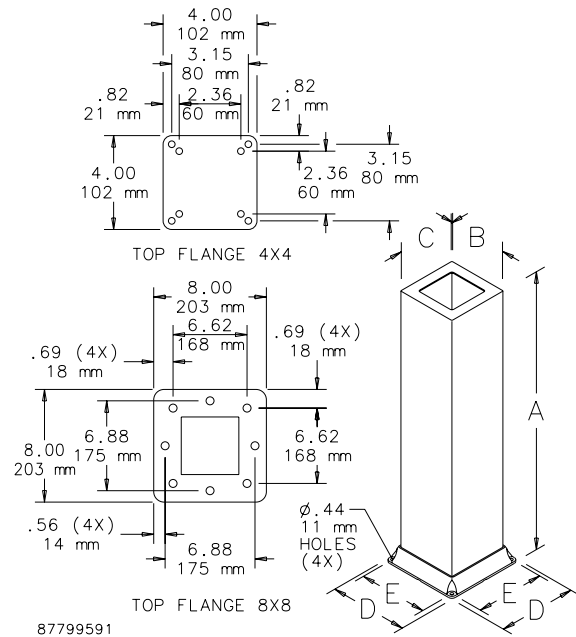

### Extension

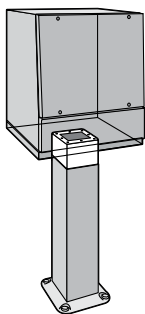

Pedestal Extension can be used with pedestals to provide additional 6 in. (152 mm) of height for standing position. ANSI 61 medium-gray polyester powder paint or RAL 7035 textured light-gray polyester powder paint.

Bulletin: P1

Catalog Number	AxBxC in./mm	Finish	Description
APE688	6.00 x 8.00 x 8.00 152 x 203 x 203	ANSI 61	Steel
APE688LG	6.00 x 8.00 x 8.00 152 x 203 x 203	RAL 7035	Steel

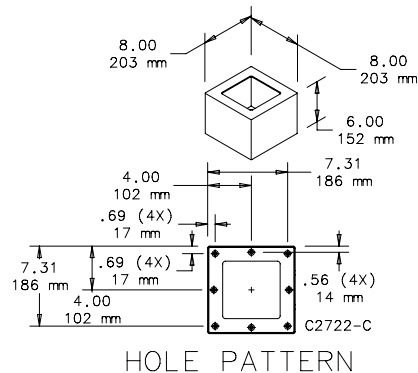

## Pedestals and Pedestal Accessories

### Stainless Steel Pedestal



Pedestal is 36-in. (914-mm) tall and provides optimal viewing and operating height. Tube is 14 gauge Type 304 one-piece construction. Legs are 7 gauge Type 304 for rigidity. Cable access plate and leg levelers are included. Leg levelers can be removed for anchoring pedestal to floor. Pedestal has smooth vertical brushed finish. Pedestal will accept pedestal accessories that are not stainless steel. These include swivel tilt, swivel and angle adapters.

Bulletin: P1S

Catalog Number	A in./mm	Description
AP36SS	36.00 914	Stainless steel

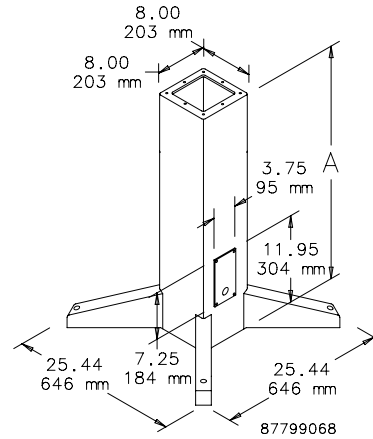

### Stainless Steel Extension

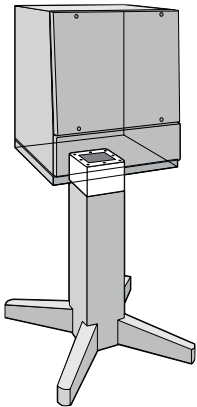

Pedestal Extension can be ordered separately to provide additional 6 in. (152 mm) of height for standing position. Extension is 14 gauge Type 304 stainless steel with a smooth brushed finish. Extension will accept pedestal accessories that are not stainless steel. These include swivel tilt, swivel and angle adapters.

Bulletin: P1S

Catalog Number	Description
APE6SS	Stainless steel

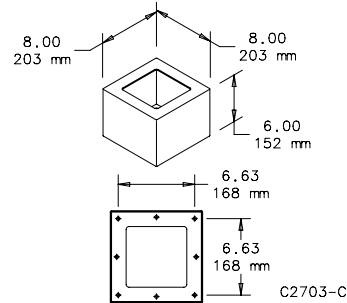

HOLE PATTERN

### Swivel and Swivel Tilt Loading

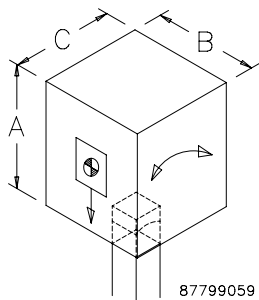

Catalog Number	Description	Maximum Enclosure Size	
		A x B x C	Maximum Load Including Enclosure
AST44	4 x 4 Swivel Tilt	610 x 610 x 406	75 lbs.
		24.00 x 24.00 x 16.00	
AST88	8 x 8 Swivel Tilt	838 x 610 x 610	150 lbs.
		33.00 x 24.00 x 24.00	
ASWV44	4 x 4 Swivel	610 x 610 x 406	100 lbs.
		24.00 x 24.00 x 16.00	
ASWV88	8 x 8 Swivel	838 x 610 x 610	200 lbs.
		33.00 x 24.00 x 24.00	

The loads listed assume that the additional load is centered on the front or back of the enclosure. Please contact Hoffman for specific application information.

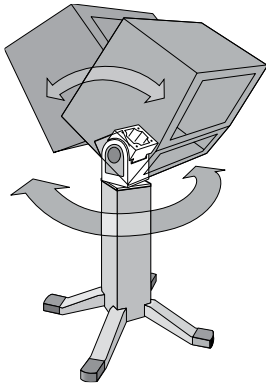
**Pedestals and Pedestal Accessories**
**Swivel Tilt**

The use of a combination swivel and tilt mechanism allows a machine operator to rotate and also tilt an HMI enclosure for optimum viewing and safe operation. The Swivel Tilt is designed for use between the bottom of an HMI enclosure and a pedestal (enclosure reinforcement may be required).

**Do not use the Swivel Tilt between an overhead support and an enclosure.**

The swivel feature allows maximum rotation of 350 degrees. Integral stops are provided at 30-degree increments between 60 degrees and 180 degrees of rotation. Swivel can be locked in any position. Tilt feature allows forward and backward movement up to 30 degrees from horizontal. Tilt lock has a large release knob that allows quick incremental adjustment. Top and bottom flanges allow easy installation on pedestals. A large center opening accommodates control cables that have attached plugs. Swivel Tilt is cast aluminum with an anodized finish. Mounting hardware and gaskets are furnished.

Bulletin: P1

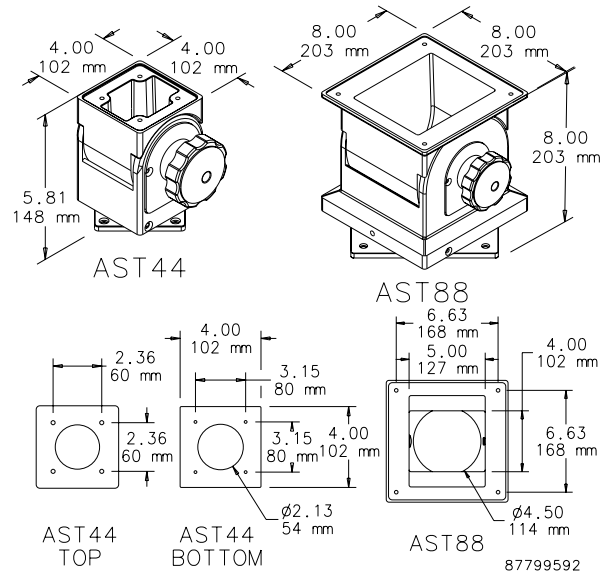

Catalog Number	AxBxC mm/ in.	Maximum Enclosure Size A x B x C mm/in.	Maximum Load Including Enclosure (kg)	Maximum Load Including Enclosure (lb.)
AST44	148 x 102 x 102 5.81 x 4.00 x 4.00	610 x 610 x 406 24.00 x 24.00 x 16.00	34.0	75
AST88	203 x 203 x 203 8.00 x 8.00 x 8.00	838 x 610 x 610 33.0 x 24.00 x 24.00	68.0	150

The loads listed assume that the additional load is centered on the front or back of the enclosure. Please contact Hoffman for specific application information.

**Swivel**

A swivel mechanism can be used to provide a machine operator a way to easily rotate an operator interface enclosure to a convenient operating position. Maximum rotation is 350 degrees. The low-profile swivel has a large center opening in addition to a large, wobble-free bearing surface. Swivel mechanism can be locked in any position. The swivel mechanism is designed for use between the bottom of an operator interface enclosure and a pedestal.

**Do not use the Swivel between an overhead support and an enclosure.**

The Swivel is cast aluminum with an anodized finish. Mounting hardware and gaskets are furnished. Integral stops are provided at 30-degree increments between 60 degrees and 180 degrees of rotation on catalog number ASWV88 only.

Bulletin: P1

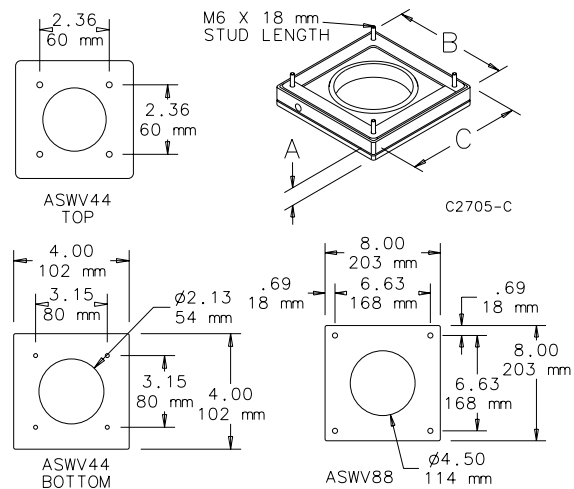

Catalog Number	AxBxC mm/ in.	Maximum Enclosure Size A x B x C mm/in.	Maximum Load Including Enclosure (kg)	Maximum Load Including Enclosure (lb.)
ASWV44	27 x 102 x 102 1.06 x 4.00 x 4.00	610 x 610 x 406 24.00 x 24.00 x 16.00	45.4	100
ASWV88	33 x 203 x 203 1.28 x 8.00 x 8.00	838 x 610 x 610 33.00 x 24.00 x 24.00	90.7	200

The loads listed assume that the additional load is centered on the front or back of the enclosure. Please contact Hoffman for specific application information.

## Pedestals and Pedestal Accessories

### Angle Adapter



Angle Adapter fits top of pedestal and provides a fixed tilt of 15 degrees from horizontal for enclosure mounting. Angle Adapter is aluminum with large cable opening and has clear anodized aluminum finish. Mounting hardware is included.

Bulletin: P1

Catalog Number	Fits
AAA1544	4 x 4 pedestal
AAA1588	8 x 8 pedestal

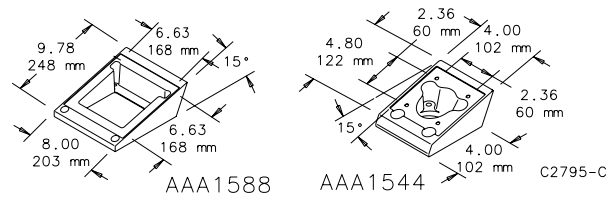

### Handles



Handles attach to sides, top or bottom of sloped front to provide maximum operator control when using the suspension system, swivel or swivel tilt. Location dimples on the sides of sloped fronts indicate drill-hole location for standard mounting. Handles attach inside enclosure.

Bulletin: DEC1, P1

Catalog Number	Description	Fits
PUHK	(2) die-cast aluminum handles (9.75 in./248 mm)	PROLINE Sloped-Fronts
PUHKA	(2) tubular steel handles with soft coating (9.75 in./248 mm)	PROLINE Sloped-Fronts
ERCFH3U	132 mm	Desktop Case
ERCFH4U	177 mm	Desktop Case
ERCFH6U	266 mm	Desktop Case

### Pedestal Caster Kits



Casters can be used on pedestals in limited applications. They are attached to the die-cast legs of steel Pedestals. Casters are also available for Stainless Steel Pedestals (AC4M6SV or AC4M6ST). Four dual-wheel casters replace furnished levelers.

Bulletin: C1, DEC1

Catalog Number	Description	Number of Casters	Height (in.)	Height (mm)	Wheel Dia. (in.)	Wheel Dia. (mm)	Load Rating Ea. (lb.)	Load Rating Ea. (kg)
AC4M6SV	Castors, swivel type with brakes	2	3.72	94	3.00	76	210	95
AC4M6ST	Castors, stationary type	2	3.72	94	3.00	76	210	95
EMRCK	Castors, swivel non-locking for steel pedestals	4	2.76	70	1.97	50	132	60

Two sets of AC4M6SV and AC4M6ST casters are required.

Height columns show height of caster when installed.

### Stainless Steel Legs



Legs mount to the bottom of a solid base to elevate the enclosure 4 in. (100 mm) from the floor. The legs are made of Type 304 stainless steel and are appropriate for hose-down applications. Mounting hardware is included.

Bulletin: P20S

Catalog Number	Description
PLEGSS	(4) Stainless Steel Legs

