

UNIFLOOD-MINI

26W-150W

Highly efficient floodlights featuring a modern, attractive design profile. Available in a wide range of light sources and high performance photometrics including a choice of symmetrical, asymmetrical and circular narrow beam versions. Suitable for many applications including extreme weather conditions and climates where both high and low temperatures are experienced.

For dusk to dawn operation, photocell versions are available for all types. To order affix part No. with P/C

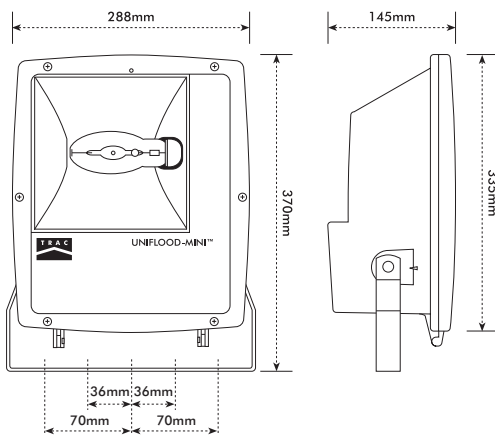

16

TECHNICAL SPECIFICATIONS

RATINGS	IP65 Ta 25°C Max
HOUSING & FRAME	Thermo-plastic polycarbonate
DIFFUSERS	Standard glass or polycarbonate
REFLECTORS	Anodised polished aluminium
CONTROL GEAR	Available with a wide variety of options
LAMP HOLDER	Ceramic with silver plated contacts
SUPPLY	Hinged front cover opening
EQUIPMENT	Corrosion and anti-seizure proof
STANDARDS	Certified to EN 60598 IP65
COLOURS	Black RAL 9011, White RAL 9003

PRODUCT PICTOGRAPHS



SYMMETRIC REFLECTOR

POLYCARBONATE IP65

HIGH PRESSURE SODIUM (E27)	Wt.(kg)	PART No.
50W	3.90	UM50S
70W	3.90	UM70S

MERCURY BLENDED FLU. (E27)	Wt.(kg)	PART No.
50W	3.90	UM50M
80W	3.90	UM80M
125W	3.93	UM125M

METAL HALIDE (RX7s)	Wt.(kg)	PART No.
70W	4.00	UM70MHL
150W	4.00	UM150MHL

COMPACT FLUORESCENT (PLT)	Wt.(kg)	PART No.
26W	3.00	UM26
32W	3.10	UM32
42W	3.20	UM42

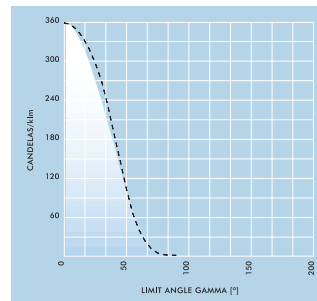

SYMMETRIC REFLECTOR
Photometric UM70S HPS 70W E27

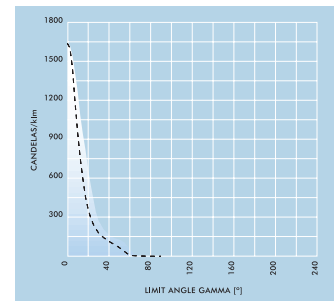

CIRCULAR PROJECTOR
Photometric UM150P HQ1 150W RXX



ASYMMETRIC REFLECTOR
POLYCARBONATE IP65

HIGH PRESSURE SODIUM (E27)	Wt.(kg)	PART No.
50W	3.90	UMA50S
70W	3.92	UMA70S

CIRCULAR PROJECTOR 30°
POLYCARBONATE IP65

METAL HALIDE (RX7s)	Wt.(kg)	PART No.
70W	4.00	UMP70
150W	4.30	UMP150

POLYCARBONATE LENS
POLYCARBONATE IP65

HIGH PRESSURE SODIUM (E27)	Wt.(kg)	PART No.
50W	4.10	PUM50S
70W	4.20	PUM70S

METAL HALIDE (RX7s)	Wt.(kg)	PART No.
70W	4.00	UMA70MHL
150W	4.00	UMA150MHL

CIRCULAR PROJECTOR 18°
POLYCARBONATE IP65

METAL HALIDE (G12)	Wt.(kg)	PART No.
70W	4.00	UMNP70
150W	4.30	UMNP150

MERCURY BLENDED FLU. (E27)	Wt.(kg)	PART No.
50W	4.05	PUM50M
80W	4.05	PUM80M

METAL HALIDE (RX7s)	Wt.(kg)	PART No.
70W	4.20	PUM70MHL
150W	4.30	PUM150MHL

ACCESSORIES

Available in colours as shown

DESCRIPTION	COLOUR	PART No.
1. Steel wire guard	-	UMWAG
2. Steel Screen louvre	Black	UMAL
3. Visor	Black	UMV
Screen printed spare glass	Black	UMSG
Adjustable barn doors	Black	UMBD
Wire mesh protective cage	Black	UMC
Colour tinted glass lens	-	UMTG

