

All information is subject to change without notice. Please read bottom notes.

FEATURES

- (1) 8.4" SVGA color display with High Brightness (350cd/m²).
- (2) Wide viewing angle and wide operating temperature.
- (3) Built in Long Life CCFLs (MTBF:50,000 h).
(Conditions / Ta:25°C I_{FL}:6.0mA(rms)(continuing lighting), f_{FL}:40kHz)
- (4) Replaceable structure of lamp units.
- (5) RoHS compatible
- (6) Mounting compatible with LTM08C351 series.

TENTATIVE**RoHS compatible****MECHANICAL SPECIFICATIONS**

Item	Specifications
Dimensional Outline (Typ.)	199.5 (W) x 149.5 (H) x 12.0 (D) mm
Number of Pixels	800 (W) x 600 (H) pixels
Active Area	170.4 (W) x 127.8 (H) mm
Pixel Pitch	0.213 (W) x 0.213 (H)
Weight (approximately)	(TBD)
Backlight	Sidelight (2 CCFLs)

ABSOLUTE MAXIMUM RATINGS

Item	Min.	Max.	Unit	
Supply Voltage	(V _{DD})	-0.3	4.0	V
	(V _{FL})	0	2.0	kV(rms)
FL Driving Frequency	(f _{FL})	---	100	kHz
Input Signal Voltage	(V _{IN})	-0.3	V _{DD} +0.3	V
Operating Temperature		-20	70	°C
Storage Temperature		-30	80	°C
Storage Humidity (Max. wet bulb temp. = 39°C)		10	90	%(RH)

ELECTRICAL SPECIFICATION (RECOMMENDED OPERATION CONDITION)

Item	Min.	Typ.	Max.	Unit	Remarks	
Supply Voltage	(V _{DD})	3.0	3.3	3.6	V	
	(V _{FL})	---	480	---	V(rms)	I _{FL} =6.0 mA(rms)
FL Start Voltage	(V _{SFL})	1300	---	1600	V(rms)	Ta=0°C
Differential Input Voltage	(V _{ID})	0.1	---	0.6	V	
Common Mode Input Voltage	(V _{CM})	1.0	1.25	2.4-(V _{ID})/2	V	
Current Consumption	(I _{DD}) ^{*1}	---	(TBD)	---	mA	
	(I _{FL}) ^{*2}	3.0	---	6.5	mA(rms)	
Power Consumption ^{*1*2}	---	(TBD)	---	W	I _{FL} =6.0 mA(rms)	

*1 : 8 color bars pattern *2 : Excepting the efficiency FL inverter

OPTICAL SPECIFICATION (Ta=25°C)

Item	Min.	Typ.	Max.	Unit	Remarks
Contrast Ratio	(CR)	(TBD)	(TBD)	---	
Viewing Angle (CR ≥ 10)	(Upper+Lower)	---	100	---	°
	(Left+Right)	---	120	---	°
Response Time	(t _{ON})	---	(20)	---	ms
	(t _{OFF})	---	(25)	---	ms
Luminance	(L)	(280)	(350)	---	cd/m ² I _{FL} =6.0mA(rms)
Lamp Life Time (MTBF) ^{*3 *4}		50,000			h

*3 : Conditions ; Ta=25°C, I_{FL}=6.0mA(rms), continuous lighting

*4 : Definitions of failure ; 1) Lcd luminance becomes half of the minimum value. 2) Lamp doesn't light normally.

*The information contained herein is presented only as a guide for the applications of our products. No responsibility is assumed by Toshiba Matsushita Display Technology or other rights of the third parties which may result from its use. No license is granted by implication or otherwise under any patent or patent rights of Toshiba Matsushita Display Technology or others.

*The information contained herein may be changed without prior notice. It is therefore advisable to contact Toshiba Matsushita Display Technology before proceeding with the design of equipment incorporating this product.

DIMENSIONAL OUTLINE (front)

Unit : mm

Standard tolerance : ±0.5

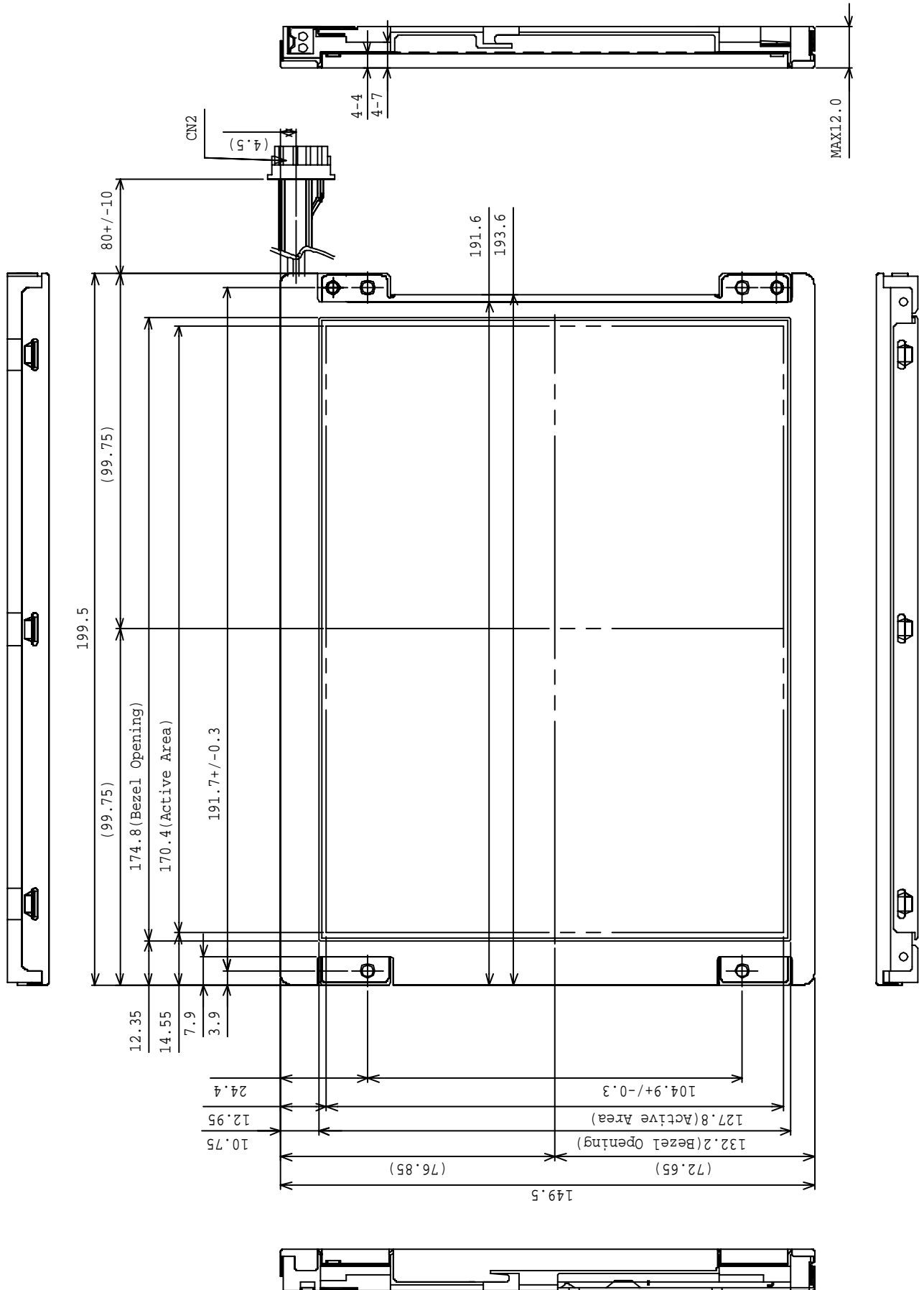

Unit : mm

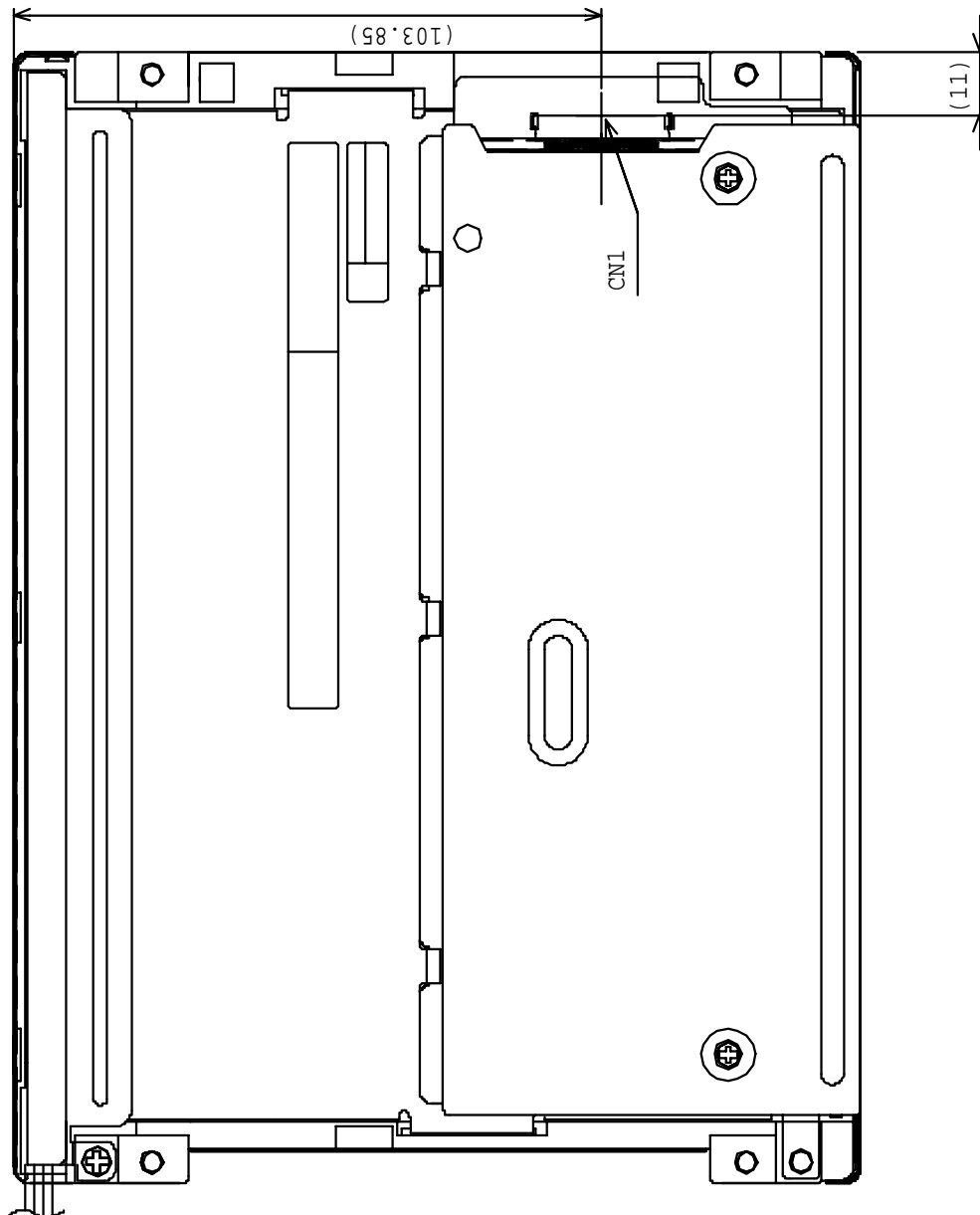
Standard tolerance : ± 0.5 **DIMENSIONAL OUTLINE (rear)**

Note) The different points between LTA084C270F and LTM08C351L are below.

- 1) The lamp unit of LTM08C351L can not use for LTA084C270F.
But the lamp unit of LTA084C270F can use for LTM08C351L.
- 2) The rear structure is changed.
The Metal PCB shield is added and the Plastic frame design is different from LTM08C351L.
There are slight differences. (Refer to page.3 rear dimensional outline in detail.)
- 3) LTA084C270F Bezel Opening is wider than that of LTM08C351L.
- 4) The reverse function (REV) is added.
(Refer to page.7 Pin Assignment No.17.)
- 5) LTA084C270F Viewing angle and Operating temperature are wider than LTM08C351L.
- 6) LTA084C270F total weight is different from LTM08C351L. (Refer to page.1 mechanical specification.)

BLOCK DIAGRAM

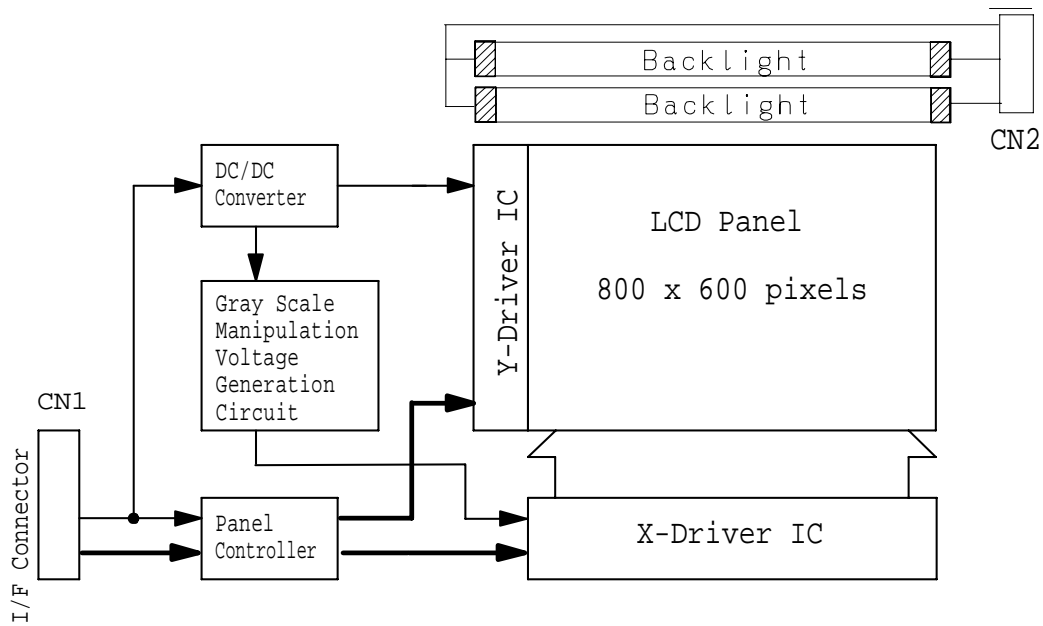

1, 1	2, 1	-----	X _{2n-1} , 1	X _{2n} , 1	-----	800, 1	600 pixels
1, 2	2, 2	-----	X _{2n-1} , 2	X _{2n} , 2	-----	800, 2	
⋮	⋮		⋮	⋮		⋮	
1, Y	2, Y	-----	X _{2n-1} , Y	X _{2n} , Y	-----	800, Y	
⋮	⋮		⋮	⋮		⋮	
1, 600	2, 600	-----	X _{2n-1} , 600	X _{2n} , 600	-----	800, 600	

SEQUENCE OF POWER SUPPLIES AND SIGNALS

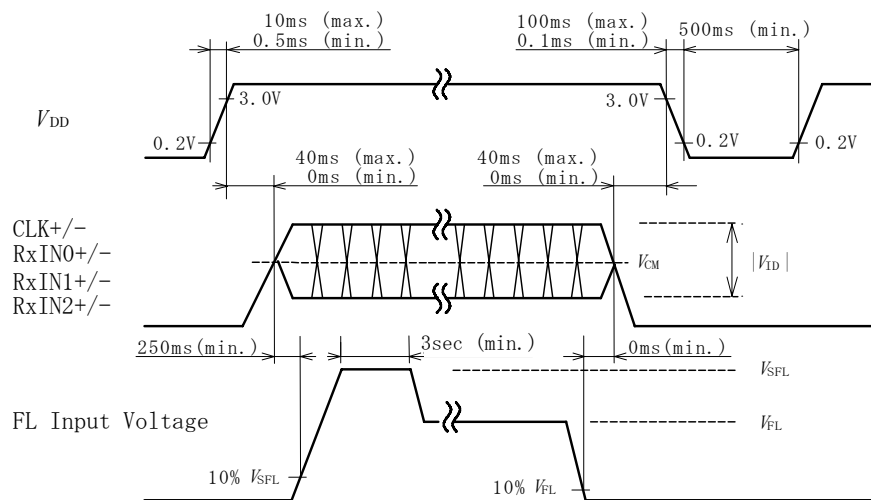

TIMING CHART

(1) Vertical Timing

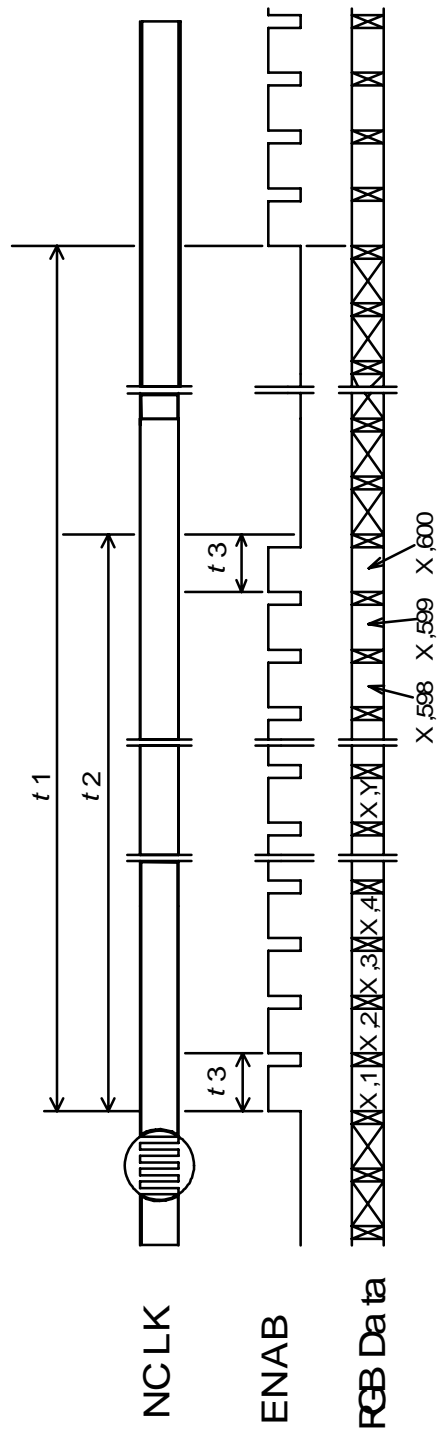

(2) Horizontal Timing

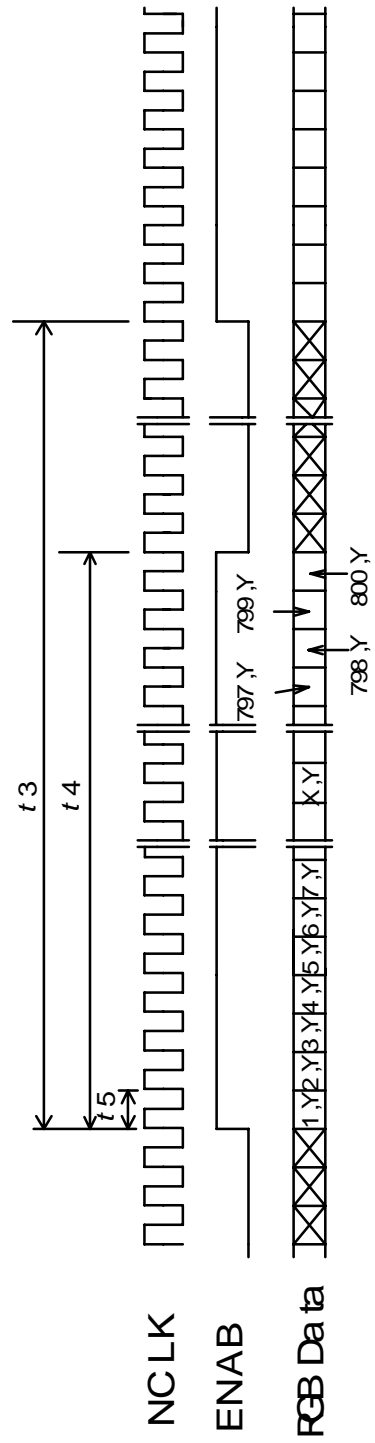

TIMING SPECIFICATION *1 *2 *3 *4 *5 *6

Item	Symbol	Min.	Typ.	Max.	Unit	Remarks
Frame Period	t1	604 x t3	628 x t3 16.58	677 x t3 17.86	---	ms
Vertical Display Term	t2	600 x t3	600 x t3	600 x t3	---	
One Line Scanning Time	t3	944 x t5 26.3	1056 x t5 26.4	1064 x t5 ---	---	μs
Horizontal Display Term	t4	800 x t5	800 x t5	800 x t5	---	
Clock Period	t5	24.7	25.0	27.8	ns	

*1 Refer to "TIMING CHART" and LVDS (DC90C365) specifications by National Semiconductor Corporation.

*2 If ENAB is fixed to "H" or "L" level for certain period while NCLK is supplied, the panel displays black with some flicker.

*3 Don't fix NCLK to "H" or "L" level while the VDD is supplied.

If NCLK is fixed to "H" or "L" level for certain period while ENAB is supplied, the panel may be damaged.

When it holds on, DC voltage supplies to liquid crystal materials and it may cause damage to liquid crystal materials.

*4 Please adjust LCD operating signal timing and FL driving frequency, to optimize the display quality.

There is a possibility that flicker is observed by the interference of LCD operating signal timing and FL driving condition (especially driving frequency), even if the condition satisfies above timing specifications and recommended operating conditions shown on page 1.

*5 Do not make t1, t2 and t3 fluctuate.

If t1, t2 and t3 are fluctuate, the panel displays black.

*6 Keep constant the number of clock within one line scanning time and the number of scanning line within one frame period.

CONNECTOR PIN ASSIGNMENT FOR INTERFACE

CN1 INPUT SIGNAL

Connector : 20268-020E-12F / I-PEX CO., LTD.

Mating Connector : 20230-020B-F or 20230-T20-F or 20230-W20B-F / I-PEX CO.,LTD.

DF19G-20S-1C(Plug), DF19-2830SCFA(Crimp contact) / HIROSE ELECTRIC CO., LTD.

Terminal No.	Symbol	Function
1	V _{DD}	+3.3V POWER SUPPLY
2	V _{DD}	+3.3V POWER SUPPLY
3	GND* ¹	
4	GND* ¹	
5	RxIN0-	Negative LVDS differential data input (R0-R5, G0)* ³
6	RxIN0+	Positive LVDS differential data input (R0-R5, G0)* ³
7	GND* ¹	
8	RxIN1-	Negative LVDS differential data input (G1-G5, B0-B1)* ³
9	RxIN1+	Positive LVDS differential data input (G1-G5, B0-B1)* ³
10	GND* ¹	
11	RxIN2-	Negative LVDS differential data input (B2-B5, HS, VS, DE)* ³
12	RxIN2+	Positive LVDS differential data input (B2-B5, HS, VS, DE)* ³
13	GND* ¹	
14	CLK-	Clock Signal (-)
15	CLK+	Clock Signal (+)
16	GND* ¹	
17	REV	Display Reverse("L" level or Open;Normal, "H" level; Reverse)
18	GND* ¹	
19	NC* ²	Non Connection (open)
20	GND* ¹	

*1 Please connect GND pin to ground. Don't use it as no-connect nor connection with high impedance.

*2 Please connect NC pin to nothing. Don't connect it to ground nor to other signal input.

*3 Refer to next page.

CN2 CCFL POWER SOURCE

Connector : BHR-04VS-1/JAPAN SOLDERLESS TERMINAL MFG CO., LTD.

Mating Connector *⁴ : SM04(4.0)B-BHS-1-TB/JAPAN SOLDERLESS TERMINAL MFG CO., LTD.

Terminal No.	Symbol	Function
1	VFLH	CCFL POWER SUPPLY (HIGH VOLTAGE)
2	VFLH	CCFL POWER SUPPLY (HIGH VOLTAGE)
3	NC* ²	
4	VFLL	CCFL POWER SUPPLY (LOW VOLTAGE)

*4 Take away terminal No.3 of the mating connector. If does not take away, it may cause smoke burn of Electrical parts by high voltage.

RECOMMENDED TRANSMITTER (DS90C365) TO LTA084C270F INTERFACE ASSIGNMENT

Case1: 6bit Transmitter

DS90C365				LTA084C270F Interface (CN1)		
Input Terminal No.		Input Signal (Graphics controller output signal)		Output Signal Symbol	Terminal	Symbol
Symbol	Terminal	Symbol	Function			
TxIN0	44	R0	Red Pixels Display Data (LSB)	TxOUT0- TxOUT0+	No.5 No.6	RxIN0- RxIN0+
TxIN1	45	R1	Red Pixels Display Data			
TxIN2	47	R2	Red Pixels Display Data			
TxIN3	48	R3	Red Pixels Display Data			
TxIN4	1	R4	Red Pixels Display Data			
TxIN5	3	R5	Red Pixels Display Data (MSB)			
TxIN6	4	G0	Green Pixels Display Data (LSB)	TxOUT1- TxOUT1+	No.8 No.9	RxIN1- RxIN1+
TxIN7	6	G1	Green Pixels Display Data			
TxIN8	7	G2	Green Pixels Display Data			
TxIN9	9	G3	Green Pixels Display Data			
TxIN10	10	G4	Green Pixels Display Data			
TxIN11	12	G5	Green Pixels Display Data (MSB)			
TxIN12	13	B0	Blue Pixels Display Data (LSB)	TxOUT2- TxOUT2+	No.11 No.12	RxIN2- RxIN2+
TxIN13	15	B1	Blue Pixels Display Data			
TxIN14	16	B2	Blue Pixels Display Data			
TxIN15	18	B3	Blue Pixels Display Data			
TxIN16	19	B4	Blue Pixels Display Data			
TxIN17	20	B5	Blue Pixels Display Data (MSB)			
TxIN18	22	NC* ¹	Non Connection (open)	TxCLK OUT- TxCLK OUT+	No.14 No.15	CLK- CLK+
TxIN19	23	NC* ¹	Non Connection (open)			
TxIN20	25	DE	Compound Synchronization Signal			
TxCLK IN	26	NCLK	Data Sampling Clock			

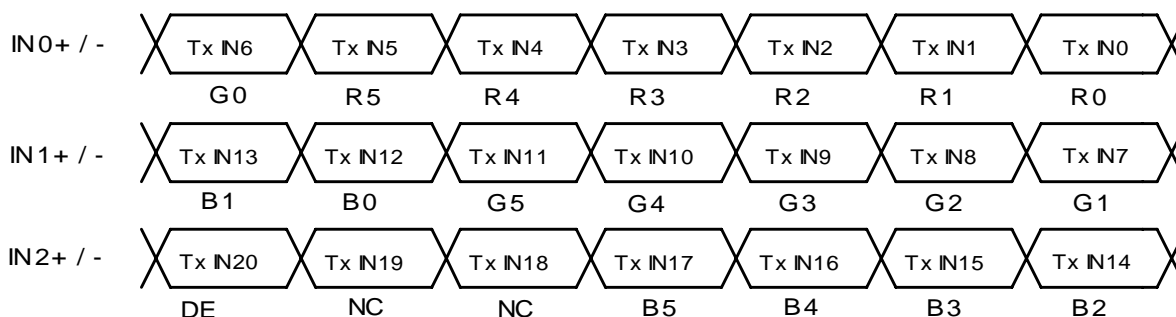

RECOMMENDED TRANSMITTER (DS90C385) TO LTA084C270F INTERFACE ASSIGNMENT

Case2: 8bit Transmitter

DS90C385				LTA084C270F Interface (CN1)		
Input Terminal No.		Input Signal (Graphics controller output signal)		Output Signal Symbol	Terminal	Symbol
Symbol	Terminal	Symbol	Function			
TxIN0	51	R0	Red Pixels Display Data (LSB)	TxOUT0- TxOUT0+	No.5 No.6	RxIN0- RxIN0+
TxIN1	52	R1	Red Pixels Display Data			
TxIN2	54	R2	Red Pixels Display Data			
TxIN3	55	R3	Red Pixels Display Data			
TxIN4	56	R4	Red Pixels Display Data			
TxIN6	3	R5	Red Pixels Display Data (MSB)	TxOUT1- TxOUT1+	No.8 No.9	RxIN1- RxIN1+
TxIN7	4	G0	Green Pixels Display Data(LSB)			
TxIN8	6	G1	Green Pixels Display Data			
TxIN9	7	G2	Green Pixels Display Data			
TxIN12	11	G3	Green Pixels Display Data			
TxIN13	12	G4	Green Pixels Display Data	TxOUT2- TxOUT2+	No.11 No.12	RxIN2- RxIN2+
TxIN14	14	G5	Green Pixels Display Data(MSB)			
TxIN15	15	B0	Blue Pixels Display Data (LSB)			
TxIN18	19	B1	Blue Pixels Display Data			
TxIN19	20	B2	Blue Pixels Display Data			
TxIN20	22	B3	Blue Pixels Display Data	TxOUT3- TxOUT3+		
TxIN21	23	B4	Blue Pixels Display Data			
TxIN22	24	B5	Blue Pixels Display Data (MSB)			
TxIN24	27	NC* ¹	Non Connection (open)			
TxIN25	28	NC* ¹	Non Connection (open)			
TxIN26	30	DE	Compound Synchronization Signal	TxCLK OUT- TxCLK OUT+	No.14 No.15	CLK- CLK+
TxIN27	50	NC* ¹	Non Connection (open)			
TxIN5	2	NC* ¹	Non Connection (open)			
TxIN10	8	NC* ¹	Non Connection (open)			
TxIN11	10	NC* ¹	Non Connection (open)			
TxIN16	16	NC* ¹	Non Connection (open)			
TxIN17	18	NC* ¹	Non Connection (open)			
TXIN23	25	NC* ¹	Non Connection (open)			
TxCLK IN	31	NCLK	Data Sampling Clock			

*1 Please connect NC pin to nothing. Don't connect it to ground nor to other signal input.

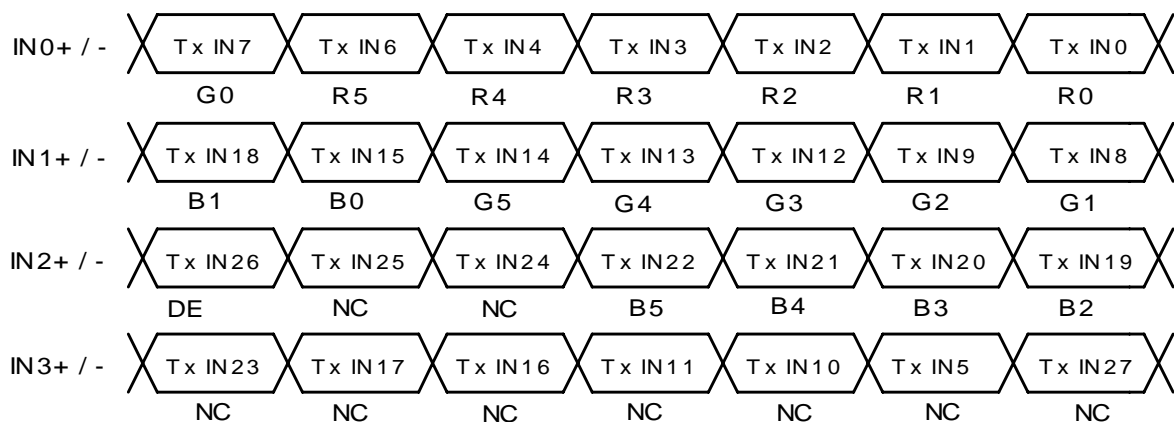

256k (k=1024) COLORS COMBINATION TABLE

	Display	R5 R4 R3 R2 R1 R0	G5 G4 G3 G2 G1 G0	B5 B4 B3 B2 B1 B0	Gray Scale Level
Basic Color	Black	L L L L L L L	L L L L L L L	L L L L L L L	---
	Blue	L L L L L L L	L L L L L L L	H H H H H H H	---
	Green	L L L L L L L	H H H H H H H	L L L L L L L	---
	Light Blue	L L L L L L L	H H H H H H H	H H H H H H H	---
	Red	H H H H H H H	L L L L L L L	L L L L L L L	---
	Purple	H H H H H H H	L L L L L L L	H H H H H H H	---
	Yellow	H H H H H H H	H H H H H H H	L L L L L L L	---
	White	H H H H H H H	H H H H H H H	H H H H H H H	---
Gray Scale of Red	Black	L L L L L L L	L L L L L L L	L L L L L L L	L 0
	Dark ↑ ↓ Light	L L L L L L H	L L L L L L L	L L L L L L L	L 1
		L L L L L H L	L L L L L L L	L L L L L L L	L 2
		: : :	: : :	: : :	L3... L60
		H H H H L L H	L L L L L L L	L L L L L L L	L61
	H H H H H L L	L L L L L L L	L L L L L L L	L62	
	Red	H H H H H H H	L L L L L L L	L L L L L L L	Red L63
	Gray Scale of Green	Black	L L L L L L L	L L L L L L L	L L L L L L L
Dark ↑ ↓ Light		L L L L L L L	L L L L L L H	L L L L L L L	L 1
		L L L L L L L	L L L L L H L	L L L L L L L	L 2
		: : :	: : :	: : :	L3... L60
		L L L L L L L	H H H H L L H	L L L L L L L	L61
L L L L L L L		H H H H H L L	L L L L L L L	L62	
Green		L L L L L L L	H H H H H H H	L L L L L L L	Green L63
Gray Scale of Blue		Black	L L L L L L L	L L L L L L L	L L L L L L L
	Dark ↑ ↓ Light	L L L L L L L	L L L L L L L	L L L L L H L	L 1
		L L L L L L L	L L L L L L L	L L L L H L L	L 2
		: : :	: : :	: : :	L3... L60
		L L L L L L L	L L L L L L L	H H H H L L H	L61
	L L L L L L L	L L L L L L L	H H H H H L L	L62	
	Blue	L L L L L L L	L L L L L L L	H H H H H H H	Blue L63
	Gray Scale of White & Black	Black	L L L L L L L	L L L L L L L	L L L L L L L
Dark ↑ ↓ Light		L L L L L L H	L L L L L L H	L L L L L L H	L 1
		L L L L L H L	L L L L L H L	L L L L L H L	L 2
		: : :	: : :	: : :	L3... L60
		H H H H L L H	H H H H L L H	H H H H L L H	L61
H H H H H L L		H H H H H L L	H H H H H L L	L62	
White		H H H H H H H	H H H H H H H	H H H H H H H	White L63

**FOR SAFETY**

LCD module is generally designed with precise parts to achieve light weighted thin mechanical dimensions. In using our Modules, make certain that you fully understand and put into practice the warnings and safety precautions detailed in Engineering Information No.EE-N001,"CAUTIONS AND INSTRUCTIONS FOR TOSHIBA LCD MODULES". Refer to individual specifications and TECHNICAL DATA sheets (hereinafter called "TD") for more detailed technical information.

1) SPECIAL PURPOSES

A) Toshiba Matsushita Display Technology's Standard LCD Modules have not been customized for operation in extreme environments or for use in applications where performance failures could be life-threatening or otherwise catastrophic.

B) Since Toshiba Matsushita Display Technology's Standard LCD Modules have not been designed for operation in extreme environments, they must never be used in devices that will be exposed to abnormally high levels of vibration or shock which exceed Toshiba Matsushita Display Technology's published specification limits.

C) In addition, since Toshiba Matsushita Display Technology Standard LCD Modules have not been designed for use in applications where performance failures could be life-threatening or catastrophic, they must never be installed in aircraft navigation control systems (such as, but not limited to Traffic Collision Avoidance System and Air Traffic Indicator), in military defense or weapons systems, in critical industrial process-control systems (e.g., those involved in the production of nuclear energy), or in critical medical device or patient life-support systems.

2) DISASSEMBLING OR MODIFICATION

DO NOT DISASSEMBLE OR MODIFY the module. It may damage sensitive parts inside LCD module, and may cause scratches or dust on the display.

Toshiba Matsushita Display Technology does not warrant the module, if customer disassembled or modified it.

3) BREAKAGE OF LCD PANEL

DO NOT INGEST liquid crystal material, DO NOT INHALE this material, and DO NOT CONTACT the material with skin, if LCD panel is broken and liquid crystal material spills out.

If liquid crystal material comes into mouth or eyes, rinse mouth or eyes out with water immediately.

If this material contact with skin or cloths, wash it off immediately with alcohol and rinse thoroughly with water.

4) GLASS OF LCD PANEL

BE CAREFUL WITH CHIPS OF GLASS that may cause injuring fingers or skin, when the glass is broken.

5) ELECTRIC SHOCK

DISCONNECT POWER SUPPLY before handling LCD module.

DO NOT TOUCH the parts inside LCD module and the fluorescent lamp's connector or cables in order to prevent electric shock, because high voltage is supplied to these parts from the inverter unit while power supply is turned on.

6) ABSOLUTE MAXIMUM RATINGS AND POWER PROTECTION CIRCUIT

DO NOT EXCEED the absolute maximum rating values under the worst probable conditions caused by the supply voltage variation, input voltage variation, variation in parts' constants, environmental temperature, etc., otherwise LCD module may be damaged.

Employ protection circuit for power supply, whenever the specification or TD specifies it.

Suitable protection circuit should be applied for each system design.

7) RECOMMENDED OPERATION CONDITIONS

The performance and quality of the LCD panel are warranted only when the LCD panel is used within "the recommended operation conditions". Toshiba Matsushita Display Technology Co., Ltd. never warrants the performance and quality of the LCD panel when you use the LCD panel over "the recommended operation conditions", although within "the absolute maximum rating".

To use the LCD panel over "the recommended operation conditions" may have bad influence on the characteristics and reliability of the LCD panel and may shorten the life of the LCD panel.

Therefore, when designing the whole set, not to be over "the recommended operation conditions", you should fully take care of supply voltage change, characteristic of connection parts, surge of input-and-output line, and surrounding temperature.

8) DISPOSAL

When dispose LCD module, obey to the applicable environmental regulations.