

# 18W LOW ENERGY DUSK-DAWN BULKHEAD

**Cat No. EC018B**



Instructions

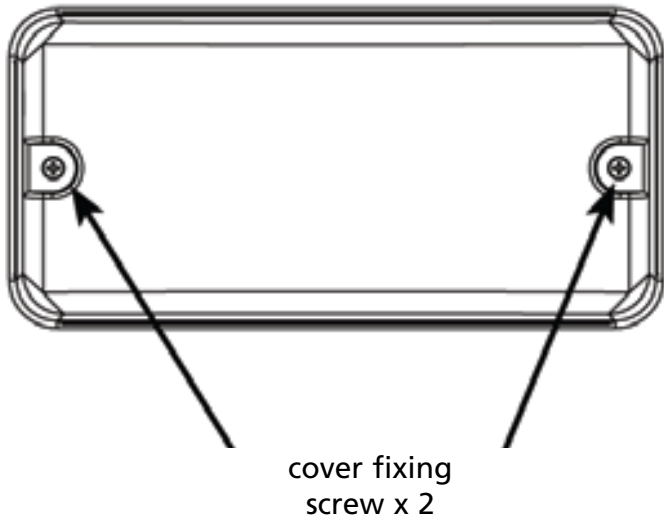
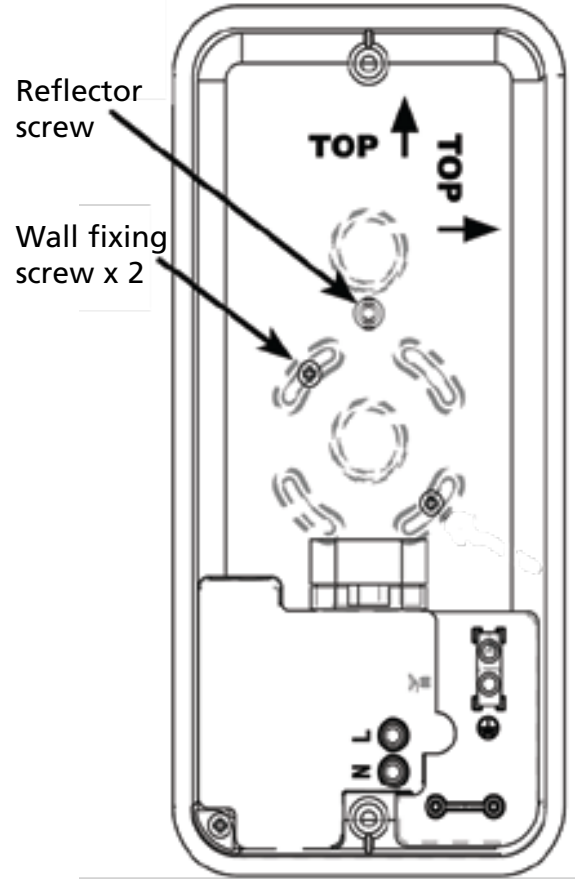
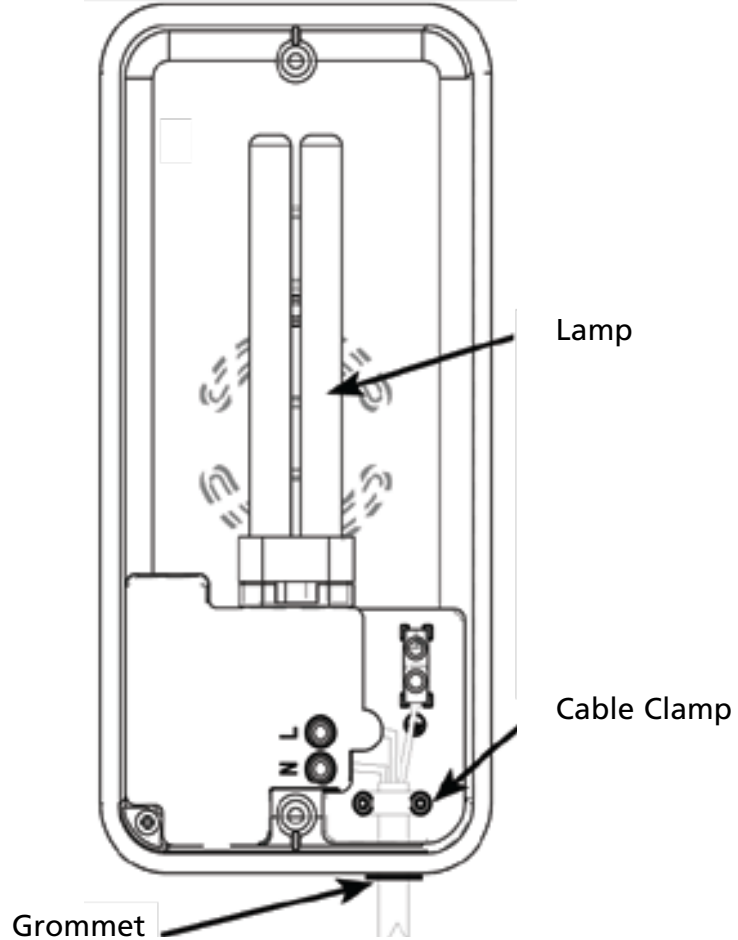

PROTECTOR  
INSTRUCTIONS  
PROTECTOR  
SMC

**A****B****C**

## **SECTION ONE**

### **GENERAL INFORMATION**

This bulkhead luminaire features an integral daylight sensing photocell which will automatically switch the light on at dusk and off at dawn.

Unit is for indoor or outdoor use. Unit must be mounted as a fixed luminaire, and is not suitable for portable use.

#### **PARTS INCLUDED**

- Low Energy utility bulkhead.
- Instruction manual. Please keep safe for future reference.
- Accessory Pack including screws and wall plugs.
- 18W PL fluorescent lamp.

#### **TOOLS & PARTS NEEDED**

- 3 flexible core cable (1.0mm<sup>2</sup> or 1.5mm<sup>2</sup>).
- Electric/hand-held drill & bits.
- Terminal or Electricians screwdriver.
- Wire cutters.

Do not attempt to install during wet weather, if you are suffering from nausea or dizzy spells or on medication with similar side effects.

#### **\*\*\* IMPORTANT \*\*\***

**Switch off the electricity at the fuse box by removing the relevant fuse or switching off the circuit breaker before proceeding with the installation.**

## **SECTION TWO**

### **INSTALLATION**

After choosing a suitable location (see previous section) install the unit as follows:

The unit is suitable for connection to a 240 V ac 50Hz electricity supply. It is suggested that 3-core round flexible cable of 1mm<sup>2</sup> or 1.5mm<sup>2</sup> gauge is used. An internal switch should be installed to switch the power to the unit ON & OFF. This allows the unit to be easily switched off when not required or for maintenance purposes.

Remove the two cover fixing screws and the remove the front cover see diagram A.

Remove the reflector by unscrewing the fixing screw and keep the screw and reflector in a safe place whilst you continue with the installation.

Based on the location of your incoming cable, place the unit in desired position.

Pierce the backplate with the fixing screws and mark the position of the mounting holes.

The unit can be mounted vertically or horizontally, ensure the lantern is positioned the correct orientation by referring the to arrows marked "TOP" in either orientation. See diagram B.

Drill holes and insert wall plugs into the holes.

Fit the unit to the wall.

Replace the reflector and fully tighten its fixing screw. See diagram B.

Remove the bulb from its packaging and fit into the lampholder. Ensure the bulb is fully secured into the lampholder. See diagram C.

Pierce and pass the cable through the grommet into the unit. see diagram C.

It is recommended that the grommet is pierced with a screwdriver to ensure a better seal.

Remove the cable clamp, feed the incoming cable under the cable clamp and secure. Do not overtighten the cable clamp as it could damage the cable insulation.

## **CONNECTION**

Connect the cable to the terminal block on the unit as follows:

NEUTRAL (Blue)            N

EARTH (Green/Yellow)   

LIVE (Brown)            L

Ensure Connections are secure.

Ensure any extra cable is tucked into the space in the wiring box.

Replace the front cover and secure using the two fixing screws as diagram A

Installation is complete!

The integral dusk sensor will automatically turn on the unit at the same level of darkness each night, and turn it off during the same level of daylight each morning.

## SECTION THREE

### TECHNICAL SPECIFICATIONS

<b>Power Supply</b>	<b>230 - 240V AC ~ 50Hz</b>
<b>Lamp Type</b>	<b>230 - 240V 18W PL-C 4pin G24q-2 Low Energy lamp</b>
<b>Environmental Protection</b>	<b>IP44 (suitable for outdoor use)</b>
<b>EC Directives</b>	<b>Conforms to 73/23/EEC, 89/336/EEC</b>

**If you experience problems refer to Troubleshooting Guide.  
If problems still exist, do not immediately return the unit to store.**

**Telephone the Timeguard Customer Helpline**

**020 8450 0515**

**Qualified Customer Support Co-ordinators will be on-line to assist in resolving your query.**



In the unlikely event of this product becoming faulty due to defective material or manufacture, within 1 year of the date of purchase, please return it to your supplier with proof of purchase and it will be replaced free of charge. In the second and third years or any difficulty in the first please contact our helpline on 020 8450 0515.

For assistance with the product please contact:-

**HELPLINE**

**020-8450-0515**

or email [helpline@timeguard.com](mailto:helpline@timeguard.com)



For a product brochure please contact:

**Timeguard Ltd.**

Victory Park, 400 Edgware Road,  
London NW2 6ND Tel: 020-8452-1112  
or email [csc@timeguard.com](mailto:csc@timeguard.com)

A **theben** Group company

67-058-313 (Iss.1)