

MOC3020X, MOC3021X, MOC3022X, MOC3023X  
MOC3020, MOC3021, MOC3022, MOC3023



**ISOCOM**  
COMPONENTS

**OPTICALLY COUPLED BILATERAL  
SWITCH NON-ZERO CROSSING  
TRIAC**



**APPROVALS**

- UL recognised, File No. E91231 under Package System 'KK'

**'X' SPECIFICATION APPROVALS**

- VDE 0884 in 3 available lead forms :-  
- STD  
- G form  
- SMD approved to CECC 00802

**DESCRIPTION**

The MOC302\_ series are optically coupled isolators consisting of a Gallium Arsenide infrared emitting diode coupled with a light activated silicon bilateral switch performing the functions of a triac mounted in a standard 6 pin dual-in-line package.

**FEATURE**

- Options :-  
10mm lead spread - add G after part no.  
Surface mount - add SM after part no.  
Tape & reel - add SMT&R after part no.
- High Isolation Voltage (5.3kV<sub>RMS</sub>, 7.5kV<sub>PK</sub>)
- 400V Peak Blocking Voltage
- All electrical parameters 100% tested
- Custom electrical selections available

**APPLICATIONS**

- CRTs
- Power Triac Driver
- Motors
- Consumer appliances
- Printers

**OPTION SM  
SURFACE MOUNT**

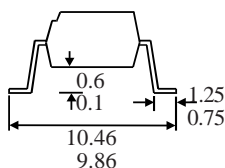

**OPTION G**

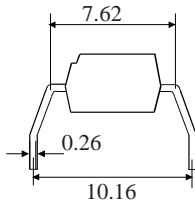

**Dimensions in mm**

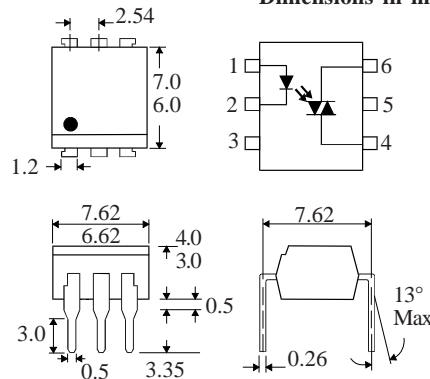

**ABSOLUTE MAXIMUM RATINGS  
(25 °C unless otherwise noted)**

Storage Temperature \_\_\_\_\_ -55°C - +150°C  
Operating Temperature \_\_\_\_\_ -40°C - +100°C  
Lead Soldering Temperature \_\_\_\_\_ 260°C  
(1.6mm from case for 10 seconds)

**INPUT DIODE**

Forward Current \_\_\_\_\_ 50mA  
Reverse Voltage \_\_\_\_\_ 6V  
Power Dissipation \_\_\_\_\_ 70mW  
(derate linearly 0.93mW/°C above 25°C)

**OUTPUT PHOTO TRIAC**

Off-State Output Terminal Voltage \_\_\_\_\_ 400V  
Forward Current (Peak) \_\_\_\_\_ 1A  
Power Dissipation \_\_\_\_\_ 300mW  
(derate linearly 4.0mW/°C above 25°C)

**POWER DISSIPATION**

Total Power Dissipation \_\_\_\_\_ 330mW  
(derate linearly 4.4mW/°C above 25°C)

**ISOCOM COMPONENTS 2004 LTD**

Unit 25B, Park View Road West,  
Park View Industrial Estate, Brenda Road  
Hartlepool, Cleveland, TS25 1UD  
Tel: (01429) 863609 Fax: (01429) 863581

**ELECTRICAL CHARACTERISTICS (  $T_A = 25^\circ\text{C}$  Unless otherwise noted )**

PARAMETER		MIN	TYP	MAX	UNITS	TEST CONDITION
Input	Forward Voltage ( $V_F$ ) Reverse Current ( $I_R$ )		1.2	1.5 100	V $\mu\text{A}$	$I_F = 10\text{mA}$ $V_R = 6\text{V}$
Output	Peak Off-state Current ( $I_{\text{DRM}}$ ) Peak Blocking Voltage ( $V_{\text{DRM}}$ ) On-state Voltage ( $V_{\text{TM}}$ ) Critical rate of rise of off-state Voltage ( $dv/dt$ ) ( note 1 ) Critical rate of rise of commutating Voltage ( $dv/dt$ ) ( note 1 )	400	1.5	100 3.0	nA V V	$V_{\text{DRM}} = 400\text{V}$ (note 1 ) $I_{\text{DRM}} = 100\text{nA}$ $I_{\text{TM}} = 100\text{mA}$ ( peak )
Coupled	Input Current to Trigger ( $I_{\text{FT}}$ ) (note 2 ) MOC3020 MOC3021 MOC3022 MOC3023  Holding Current , either direction ( $I_H$ )  Input to Output Isolation Voltage $V_{\text{ISO}}$			30 15 10 5	mA mA mA mA	$V_D = 3\text{V}$ ( note 2 )
		100			$\mu\text{A}$	
		5300 7500			$V_{\text{RMS}}$ $V_{\text{PK}}$	See note 3 See note 3

Note 1. Test voltage must be applied within  $dv/dt$  rating.

Note 2. Guaranteed to trigger at an  $I_F$  value less than or equal to max.  $I_{\text{FT}}$ , recommended  $I_F$  lies between Rated  $I_{\text{FT}}$  and absolute max.  $I_{\text{FT}}$ .

Note 3. Measured with input leads shorted together and output leads shorted together.

**FIGURE 1**

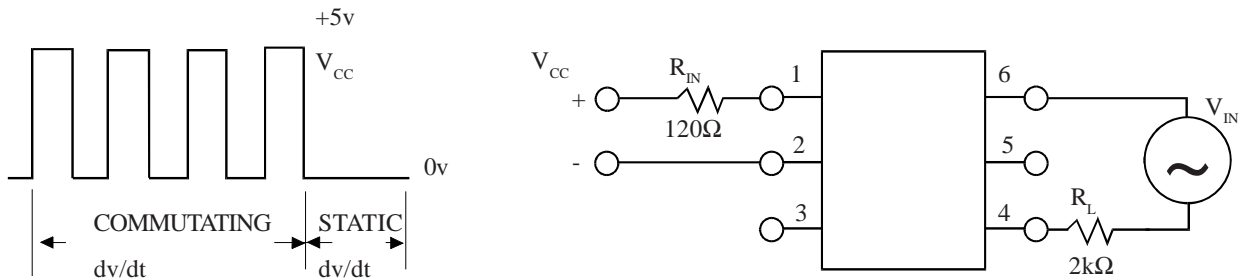

**RMS On-state Current vs. Ambient Temperature**

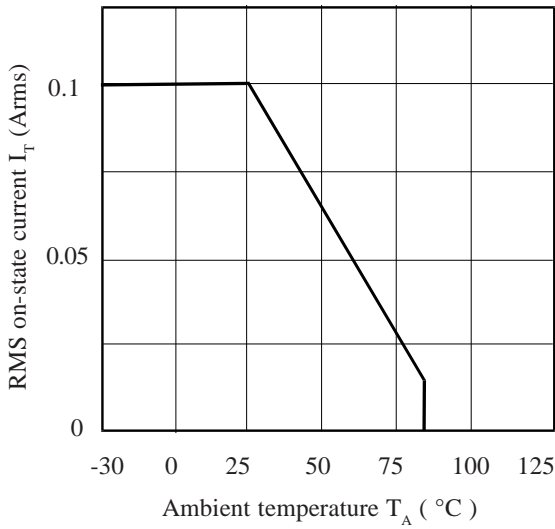

**Normalised Repetitive Peak Off-state Voltage vs. Ambient Temperature**

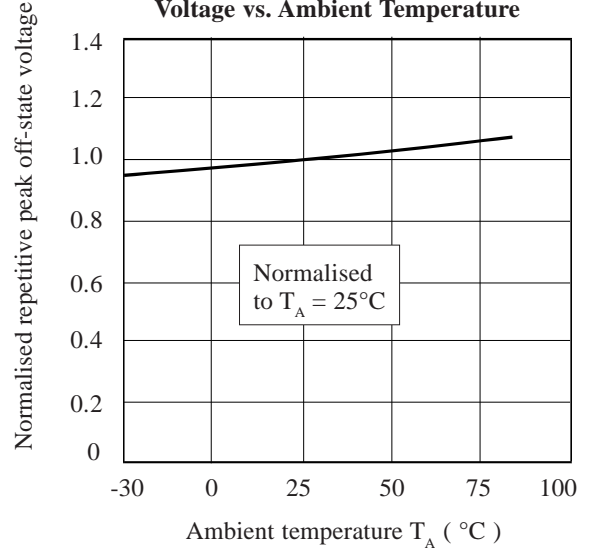

**Forward Current vs. Ambient Temperature**

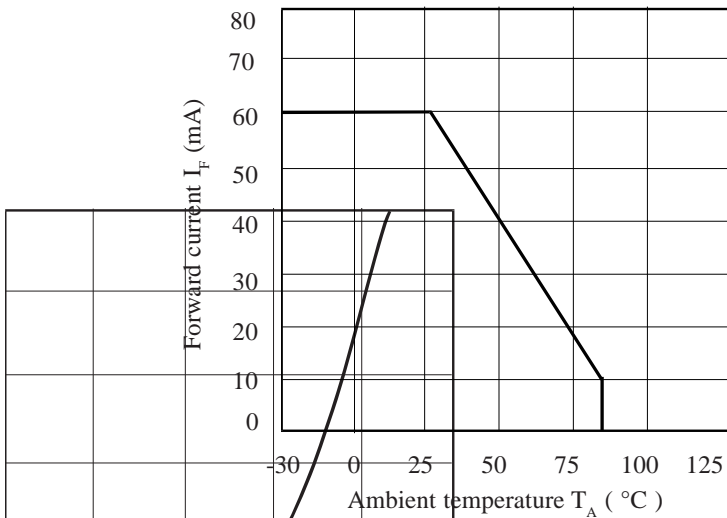

**On-state Voltage vs. Ambient Temperature**

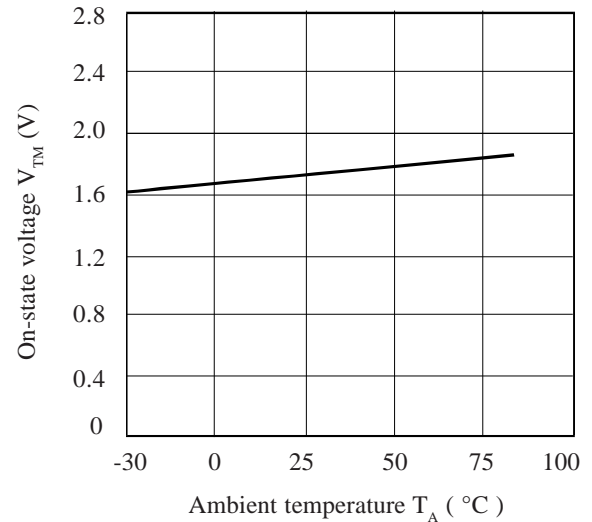

**Normalised Input Trigger Current vs. Ambient Temperature**

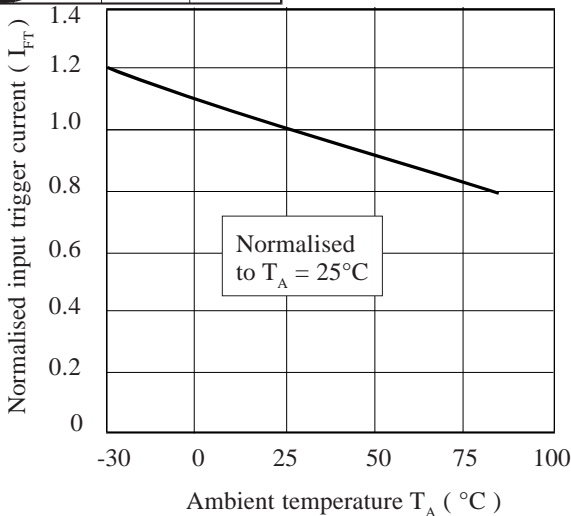

**On-state Current vs. On-state Voltage**

