

H11L1, H11L2, H11L3, H11L4



ISOCOM
COMPONENTS

**MICROPROCESSOR COMPATIBLE
SCHMITT TRIGGER OPTICALLY
COUPLED ISOLATOR**



DESCRIPTION

The H11L1, 2, 3, 4 series are optically coupled isolators consisting of a Gallium Arsenide infrared emitting diode and a Microprocessor Compatible Schmitt trigger output mounted in a standard 6 pin dual in line package.

FEATURES

- Options :-
10mm lead spread - add G after part no.
Surface mount - add SM after part no.
Tape&reel - add SMT&R after part no.
- High data rate, 1MHz typical (NRZ)
- Microprocessor compatible drive
- Logic compatible output sinks 16 milliamperes at 0.4 volts maximum
- High Isolation Voltage (5.3kV_{RMS}, 7.5kV_{PK})
- High common mode rejection ratio
- Fast switching : t_{rise}, t_{fall} = 100nS typical
- Wide supply voltage capability, compatible with all popular logic systems
- Guaranteed On / Off threshold hysteresis

APPLICATIONS

- Logic to logic isolator
- Line receiver-eliminates noise and transient problems
- Programmable current level sensor
- AC to TTL conversion - square wave shaping
- Digital programming of power supplies
- Interfaces computers with peripherals

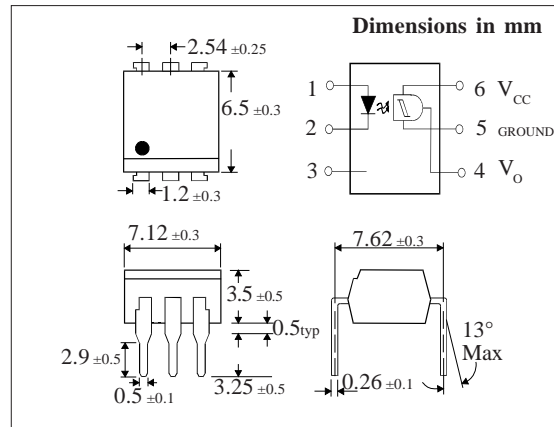

**ABSOLUTE MAXIMUM RATINGS
(25°C unless otherwise specified)**

Storage Temperature _____ -40°C to +125°C
 Operating Temperature _____ -25°C to +85°C
 Lead Soldering Temperature
 (1/16 inch (1.6mm) from case for 10 secs) 260°C

INPUT DIODE

Forward Current, I_F _____ 50mA
 Peak forward current
 (Pulse width ≤ 100uS, Duty ratio=0.001) — 1A
 Reverse Voltage, V_R _____ 6V
 Power Dissipation
 (derate linearly 1.41mW / °C above 25°C) — 70mW

OUTPUT DETECTOR

Output Voltage, V_{CC} _____ 16V
 Supply Voltage, V_{OH} _____ 16V
 Output current, I_{OL} _____ 50mA
 Power Dissipation
 (derate linearly 2mW / °C above 25°C) — 150mW

POWER DISSIPATION

Total Power Dissipation
 (derate linearly 2.94mW / °C above 25°C) — 170mW

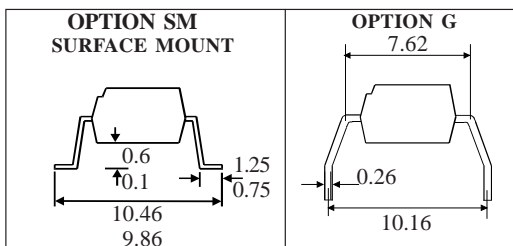

ISOCOM COMPONENTS 2004 LTD

Unit 25B, Park View Road West,
 Park View Industrial Estate, Brenda Road
 Hartlepool, Cleveland, TS25 1UD
 Tel: (01429) 863609 Fax: (01429) 863581

ELECTRICAL CHARACTERISTICS ($T_A = 25^\circ\text{C}$ Unless otherwise noted)

PARAMETER		MIN	TYP	MAX	UNITS	TEST CONDITION
Input	Forward Voltage (V_F)	0.75			V	$I_F = 0.3\text{mA}$ $I_F = 10\text{mA}$ $V_R = 3\text{V}$ $V = 0, f = 1\text{MHz}$
	Forward Voltage (V_F)			1.5	V	
	Reverse Current (I_R)			10	μA	
	Capacitance (C_j)			100	pF	
Output	Operating Voltage Range (V_{CC})	3		15	V	$I_F = 0\text{mA}, V_{CC} = 5\text{V}$ $I_F = 0\text{mA}, V_{CC} = V_O = 15\text{V}$
	Supply Current I_6 (off)		1.6	5	mA	
	Output Current High (I_{OH})			100	μA	
Coupled	Supply Current I_6 (on)		1.6	5	mA	$I_F = 10\text{mA}, V_{CC} = 5\text{V}$ $R_L = 270\Omega, V_{CC} = 5\text{V}$
	Output Voltage, Low (V_{OL})			0.4	V	
	Turn-on Threshold Current I_F (on)					$R_L = 270\Omega, V_{CC} = 5\text{V}$ $R_L = 270\Omega, V_{CC} = 5\text{V}$ $R_L = 270\Omega, V_{CC} = 5\text{V}$ $R_L = 270\Omega, V_{CC} = 5\text{V}$
	H11L1			1.6	mA	
	H11L2			10	mA	
	H11L3			5	mA	
	H11L4			2	mA	$R_L = 270\Omega, V_{CC} = 5\text{V}$
	Turn-off Threshold Current I_F (off)	0.3			mA	$R_L = 270\Omega, V_{CC} = 5\text{V}$
	Hysteresis Ratio I_F (off) / I_F (on)	0.5		0.9		$R_L = 270\Omega, V_{CC} = 5\text{V}$
	Input to Output Isolation Voltage V_{ISO}	5300			V _{RMS}	See note 1
		7500			V _{PK}	See note 1
	High to Low Propagation time	t_{PHL}	1	3	μs	$R_E = 280\Omega$
	Fall Time	t_f	0.05	0.5	μs	$V_{CC} = 5\text{V}$
Low to High Propagation time	t_{PLH}	2	6	μs	$I_F = 4\text{mA}$	
Rise Time	t_r	0.1	0.5	μs		

Note 1 Measured with input leads shorted together and output leads shorted together.

Note 2 Special Selections are available on request. Please consult the factory.

SWITCHING CHARACTERISTICS

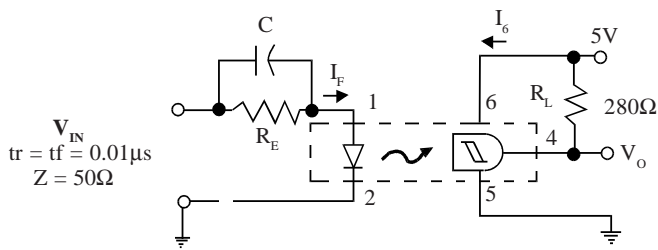

SWITCHING TEST CIRCUIT

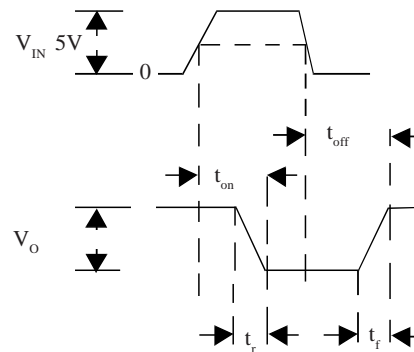

Transfer Characteristics

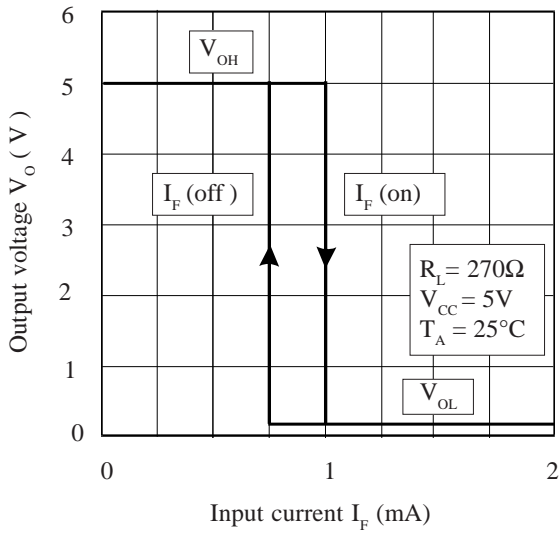

On Voltage vs. Load Current

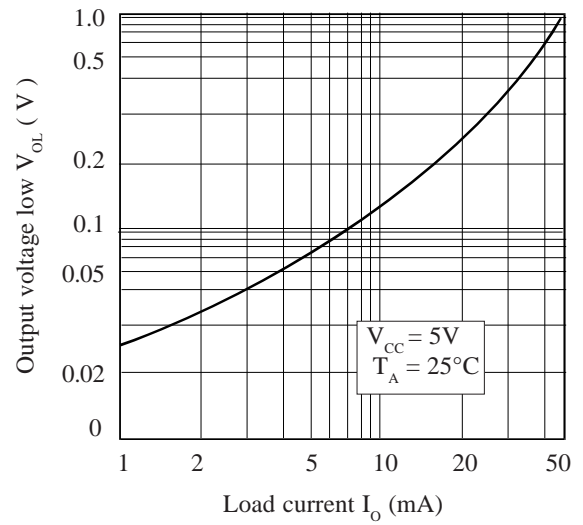

Threshold Current vs. Supply Voltage

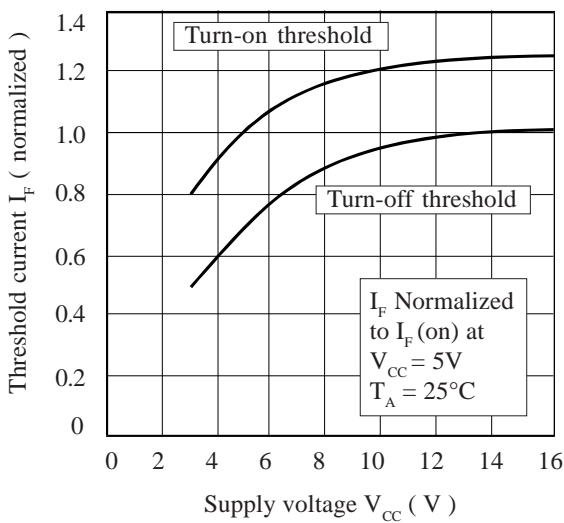

Forward Voltage vs. Forward Current

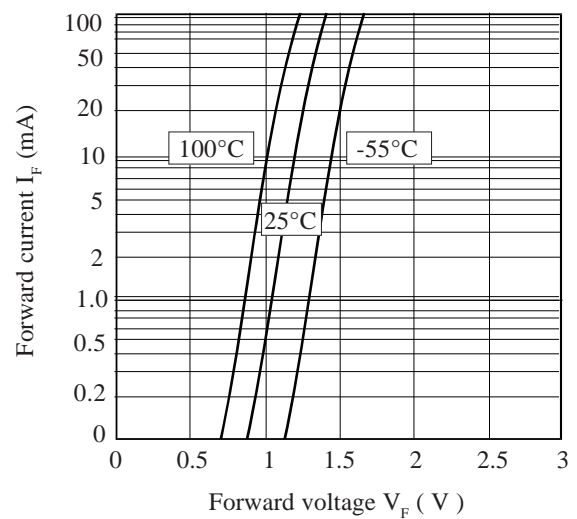

Threshold Current vs. Ambient Temperature

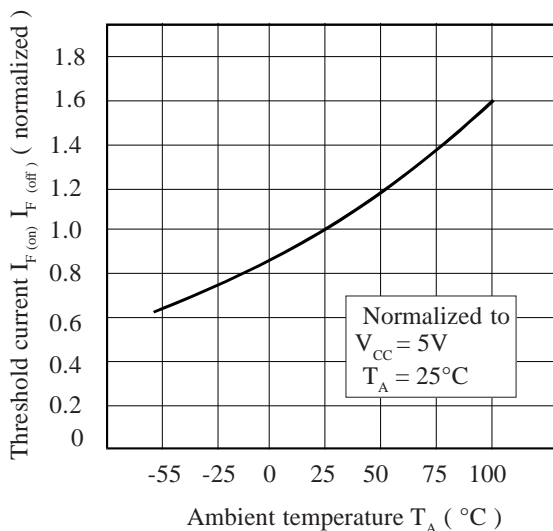

Supply Current vs. Supply Voltage

