

UNCONTROLLED DOCUMENT

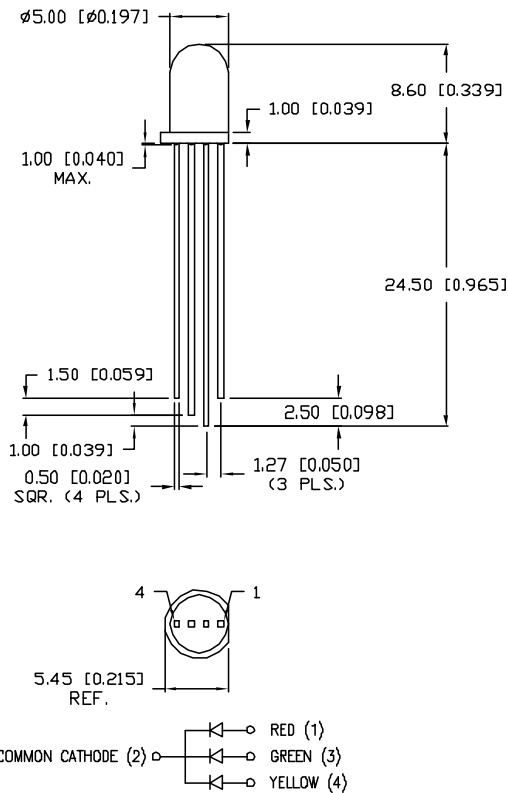

PART NUMBER		REV.
SSL-LX5097SISGSYC		A
REV.	E.C.N. NUMBER AND REVISION COMMENTS	DATE
A	E.C.N. #11148	11.03.06

ELECTRO-OPTICAL CHARACTERISTICS  $T_A=25^{\circ}\text{C}$   $I_f=20\text{mA}$

PARAMETER	MIN	TYP	MAX	UNITS	TEST COND
PEAK WAVELENGTH		636 (RED)		nm	
		565 (GREEN)		nm	
		585 (YELLOW)		nm	
FORWARD VOLTAGE (R)		2.0	2.5	$V_f$	
	(G)		2.2	2.6	$V_f$
	(Y)		2.1	2.5	$V_f$
REVERSE VOLTAGE	5.0			$V_r$	$I_f=100\mu\text{A}$
AXIAL INTENSITY (R/G/Y)		700/65/450		mcd	$I_f=20\text{mA}$
VIEWING ANGLE		50		2x theta	
EMITTED COLOR:	RED/GREEN/YELLOW				
EPOXY LENS FINISH:	WATER CLEAR				

LIMITS OF SAFE OPERATION AT 25°C

PARAMETER	COLORS	MAX	UNITS
PEAK FORWARD CURRENT*	(R/G/Y)	185/130/150	mA
STEADY CURRENT	(R/G/Y)	30/25/30	mA
POWER DISSIPATION	(R/G/Y)	170/105/102	mW
DERATE FROM 25°C		-1.2	mW/°C
OPERATING, STORAGE TEMP.		-40 TO +85	°C
SOLDERING TEMP.		+260	°C
2.0mm FROM BODY			3 SEC. MAX

\*  $t < 10\mu\text{s}$



UNCONTROLLED DOCUMENT

\*UNLESS OTHERWISE SPECIFIED TOLERANCES PER DECIMAL PRECISION ARE: X=±1 (±0.039), XX=±0.5 (±0.020), XXX=±0.25 (±0.010), XXXX=±0.127 (±0.005). LEAD SIZE=±0.05 (±0.002), LEAD LENGTH=±0.75 (±0.030). MIN= +DECIMAL PRECISION -0.00, MAX.= +0.00 -DECIMAL PRECISION

REV. A	PART NUMBER SSL-LX5097SISGSYC	<p>CONFIDENTIAL INFORMATION</p> <p>THE INFORMATION CONTAINED IN THIS DOCUMENT IS THE PROPERTY OF LUMEX INC. EXCEPT AS SPECIFICALLY AUTHORIZED IN WRITING BY LUMEX INC., THE HOLDER OF THIS DOCUMENT SHALL KEEP ALL INFORMATION CONTAINED HEREIN CONFIDENTIAL AND SHALL PROTECT SAME IN WHOLE OR IN PART FROM DISCLOSURE AND DISSEMINATION TO ALL THIRD PARTIES.</p> <p>RELIABILITY NOTE</p> <p>OUR MANY YEARS OF EXPERIENCE DATA ACCUMULATION INDICATE THAT SOLDER HEAT IS A MAJOR CAUSE OF EARLY AND FUTURE FAILURE. PLEASE PAY ATTENTION TO YOUR SOLDERING PROCESS.</p>	<p>290 E. HELEN ROAD PALATINE, IL 60067-6976 PHONE: +1.847.359.2790 US WEB: www.lumex.com TW WEB: www.lumex.com.tw</p>
T-5mm (T-1 3/4) RED/GREEN/YELLOW LED, COMMON CATHODE, 0.05" LEAD SPACING, WATER CLEAR LENS.		<p>DRAWN BY: JC</p>	<p>CHECKED BY:</p> <p>APPROVED BY:</p> <p>DATE: 11.03.06 PAGE: 1 OF 1 SCALE: N/A</p>