



ALL RIGHTS RESERVED. NO PORTION OF THIS PUBLICATION, WHETHER IN WHOLE OR IN PART CAN BE REPRODUCED WITHOUT THE EXPRESS WRITTEN CONSENT OF SPC TECHNOLOGY.

SPC-F005.DWG

REVISIONS

DOC. NO. SPC-F005 * Effective: 7/8/02 * DCP No: 1398

| DCP # | REV | DESCRIPTION | DRAWN | DATE | CHECKD | DATE | APPRVD | DATE |
|-------|-----|-------------|-------|--------|--------|---------|--------|---------|
| 1908 | A | RELEASED | EO | 6/7/06 | YA | 6/19/06 | HO | 6/19/06 |



Features:

- High intensity
- Standard T-1 diameter package
- General purpose LED
- Reliable and rugged

Specifications:

- Lead spacing is measured where the leads emerge from the package

| Source Color | Chip Material | Lens Color |
|--------------|---------------|-------------|
| Yellow Green | GaP | Water Clear |

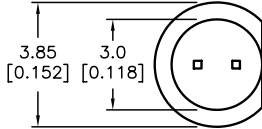

Absolute Maximum Rating at Ta=25°C

| Parameter | MAX. | Unit |
|---|---------------------|-------|
| Power Dissipation | 100 | mW |
| Peak Forward Current (1/10 Duty Cycle, 0.1ms Pulse Width) | 100 | mA |
| Continuous Forward Current | 30 | mA |
| Derating Linear From 50°C | 0.4 | mA/°C |
| Reverse Voltage | 5 | V |
| Operating Temperature Range | -25°C to +80°C | |
| Storage Temperature Range | -40°C to +100°C | |
| Lead Soldering Temperature [4mm (0.157) From Body] | 260°C for 5 seconds | |

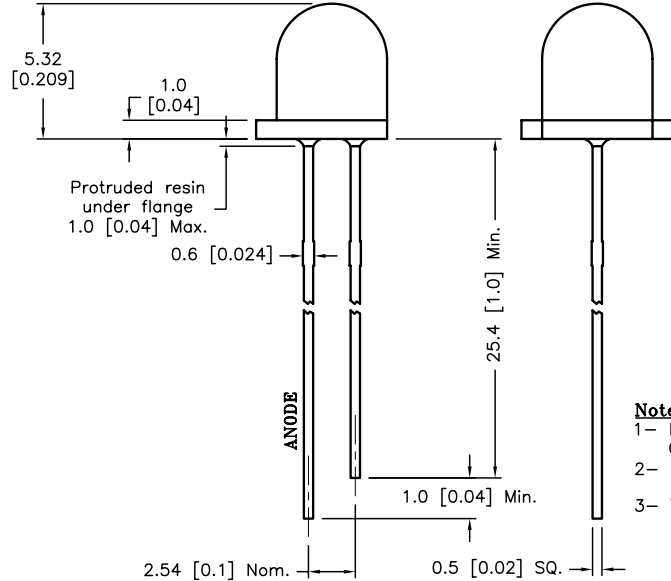

Electrical Optical Characteristics at Ta=25°C

| Parameter | Symbol | Min. | Typ. | Max | Unit | Test Condition |
|--------------------------|-----------------|------|------|-----|---------------|----------------------------|
| Luminous Intensity | I_v | | 50 | | mcd | $I_f=20\text{mA}$ (Note 1) |
| Viewing Angle | $2\theta_{1/2}$ | | 60 | | Deg | (Note 2) |
| Peak Emission Wavelength | λ_p | | 574 | | nm | $I_f=20\text{mA}$ |
| Dominant Wavelength | λ_d | | 570 | | nm | $I_f=20\text{mA}$ (Note 3) |
| Forward Voltage | V_f | | 2.0 | 2.5 | V | $I_f=20\text{mA}$ |
| Reverse Current | I_R | --- | --- | 100 | μA | $V_R=5\text{V}$ |

Notes:

- 1- Luminous intensity is measured with a light sensor and filter combination that approximates the CIE eye-response curve.
- 2- $\theta_{1/2}$ is the off-axis angle at which the luminous intensity is half the axial luminous intensity
- 3- The x and y parameters correspond to the CIE 1931 Chromaticity

DISCLAIMER:
ALL STATEMENTS AND TECHNICAL INFORMATION CONTAINED HEREIN ARE BASED UPON INFORMATION AND/OR TESTS WE BELIEVE TO BE ACCURATE AND RELIABLE. SINCE CONDITIONS OF USE ARE BEYOND OUR CONTROL, THE USER SHALL DETERMINE THE SUITABILITY OF THE PRODUCT FOR THE INTENDED USE AND ASSUME ALL RISK AND LIABILITY WHATSOEVER IN CONNECTION THEREWITH.

TOLERANCES:

UNLESS OTHERWISE SPECIFIED,
 ± 0.25 [± 0.010]

| | |
|-----------------|---------|
| DRAWN BY: | DATE: |
| EKLAS ODISH | 6/7/06 |
| CHECKED BY: | DATE: |
| YILMAZ AKYONDEM | 6/19/06 |
| APPROVED BY: | DATE: |
| HISHAM ODISH | 6/19/06 |

| | | | |
|---|---------------------|-----------------|-----|
| DRAWING TITLE: Standard LED, Round Lens, 3mm (T1), Yellow Green Emitting Color | | | |
| SIZE | DWG. NO. | ELECTRONIC FILE | REV |
| A | MV7441 | 87K7107.DWG | A |
| SCALE: NTS | U.O.M.: mm [INCHES] | SHEET: 1 OF 2 | |

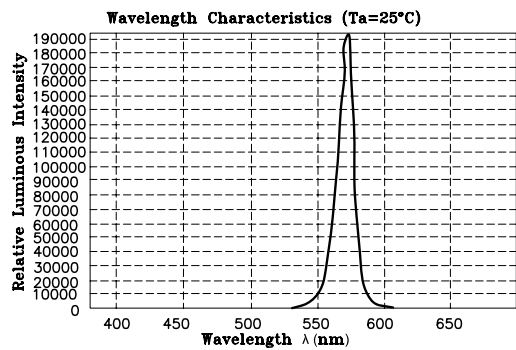
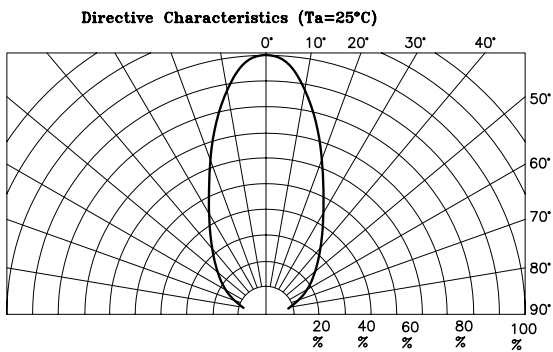
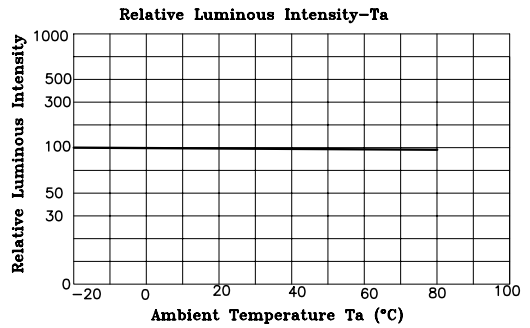
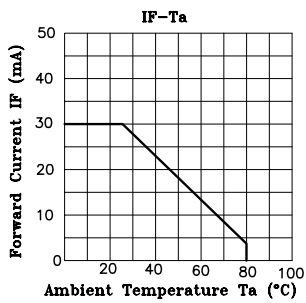
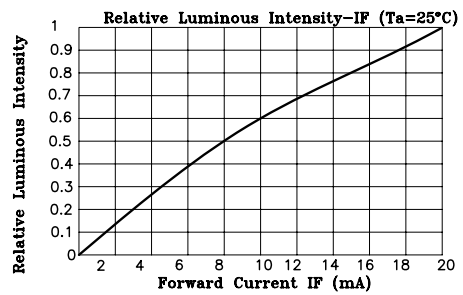
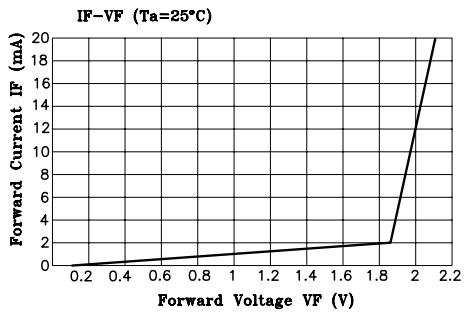

ALL RIGHTS RESERVED. NO PORTION OF THIS PUBLICATION, WHETHER IN WHOLE OR IN PART CAN BE REPRODUCED WITHOUT THE EXPRESS WRITTEN CONSENT OF SPC TECHNOLOGY.

| | | | |
|------------|---------------------|-----------------|-----|
| SIZE | DWG. NO. | ELECTRONIC FILE | REV |
| A | MV7441 | 87K7107.DWG | A |
| SCALE: NTS | U.O.M.: mm [INCHES] | SHEET: 2 OF 2 | |

SPC-F005.DWG

DOC. NO. SPC-F005 * Effective: 7/8/02 * DCP No: 1398