

## Backlighting LED in $\varnothing$ 3 mm Tinted Non-Diffused Package

### Description

The TLV.4200 series was developed for backlighting. Due to its special shape the spatial distribution of the radiation is qualified for backlighting.

To optimize the brightness of backlighting a custom-built reflector (with scattering) is required. Uniform illumination can be enhanced by covering the front of the reflector with diffusor material.

This is a flexible solution for backlighting different areas.

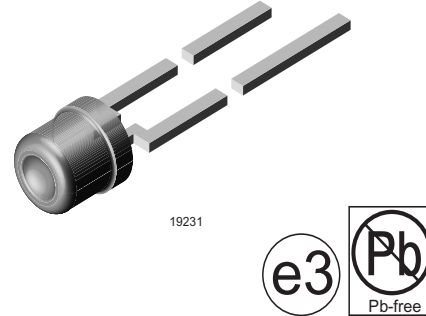

### Features

- High light output
- Wide viewing angle
- Categorized for luminous flux
- Tinted clear package
- Low power dissipation
- Low self heating
- Rugged design
- High reliability
- Lead-free device

### Applications

Backlighting of display panels, LCD displays, symbols on switches, keyboards, graphic boards and measuring scales

Illumination of large areas e.g. dot matrix displays

### Parts Table

Part	Color, Luminous Intensity	Angle of Half Intensity ( $\pm\phi$ )	Technology
TLVH4200	Red, $\phi_V > 10$ mlm	85 °	GaAsP on GaP
TLVH4201	Red, $\phi_V = (16 \text{ to } 32)$ mlm	85 °	GaAsP on GaP
TLVS4200	Soft orange, $\phi_V > 10$ mlm	85 °	GaAsP on GaP
TLVY4200	Yellow, $\phi_V > 10$ mlm	85 °	GaAsP on GaP
TLVG4200	Green, $\phi_V > 10$ mlm	85 °	GaP on GaP
TLVP4200	Pure green, $\phi_V > 4$ mlm	85 °	GaP on GaP

### Absolute Maximum Ratings

$T_{amb} = 25$  °C, unless otherwise specified

TLVH4200 , TLVS4200 , TLVY4200 , TLVG4200 , TLVP4200

Parameter	Test condition	Symbol	Value	Unit
Reverse voltage		$V_R$	6	V
DC Forward current	$T_{amb} \leq 60$ °C	$I_F$	30	mA
Surge forward current	$t_p \leq 10$ $\mu$ s	$I_{FSM}$	1	A

Parameter	Test condition	Symbol	Value	Unit
Power dissipation	$T_{amb} \leq 60\text{ }^{\circ}\text{C}$	$P_V$	100	mW
Junction temperature		$T_j$	100	$^{\circ}\text{C}$
Operating temperature range		$T_{amb}$	- 40 to + 100	$^{\circ}\text{C}$
Storage temperature range		$T_{stg}$	- 55 to + 100	$^{\circ}\text{C}$
Soldering temperature	$t \leq 5\text{ s}$ , 2 mm from body	$T_{sd}$	260	$^{\circ}\text{C}$
Thermal resistance junction/ ambient		$R_{thJA}$	400	K/W

## Optical and Electrical Characteristics

$T_{amb} = 25\text{ }^{\circ}\text{C}$ , unless otherwise specified

### Red

#### TLVH4200

Parameter	Test condition	Part	Symbol	Min	Typ.	Max	Unit
Luminous flux	$I_F = 15\text{ mA}$	TLVH4200	$\phi_V$	10	25		mlm
		TLVH4201	$\phi_V$	16		32	mlm
Dominant wavelength	$I_F = 10\text{ mA}$		$\lambda_d$	612		625	nm
Peak wavelength	$I_F = 10\text{ mA}$		$\lambda_p$		635		nm
Angle of half intensity	$I_F = 10\text{ mA}$		$\phi$		$\pm 85$		deg
Forward voltage	$I_F = 20\text{ mA}$		$V_F$		2.4	3	V
Reverse voltage	$I_R = 10\text{ }\mu\text{A}$		$V_R$	6	15		V
Junction capacitance	$V_R = 0$ , $f = 1\text{ MHz}$		$C_j$		50		pF

### Soft Orange

#### TLVS4200

Parameter	Test condition	Symbol	Min	Typ.	Max	Unit
Luminous flux	$I_F = 15\text{ mA}$	$\phi_V$	10	25		mlm
Dominant wavelength	$I_F = 10\text{ mA}$	$\lambda_d$	598		611	nm
Peak wavelength	$I_F = 10\text{ mA}$	$\lambda_p$		605		nm
Angle of half intensity	$I_F = 10\text{ mA}$	$\phi$		$\pm 85$		deg
Forward voltage	$I_F = 20\text{ mA}$	$V_F$		2.4	3	V
Reverse voltage	$I_R = 10\text{ }\mu\text{A}$	$V_R$	6	15		V
Junction capacitance	$V_R = 0$ , $f = 1\text{ MHz}$	$C_j$		50		pF

### Yellow

#### TLVY4200

Parameter	Test condition	Symbol	Min	Typ.	Max	Unit
Luminous flux	$I_F = 15\text{ mA}$	$\phi_V$	10	20		mlm
Dominant wavelength	$I_F = 10\text{ mA}$	$\lambda_d$	581		594	nm
Peak wavelength	$I_F = 10\text{ mA}$	$\lambda_p$		585		nm
Angle of half intensity	$I_F = 10\text{ mA}$	$\phi$		$\pm 85$		deg
Forward voltage	$I_F = 20\text{ mA}$	$V_F$		2.4	3	V
Reverse voltage	$I_R = 10\text{ }\mu\text{A}$	$V_R$	6	15		V
Junction capacitance	$V_R = 0$ , $f = 1\text{ MHz}$	$C_j$		50		pF

## Green

### TLVG4200

Parameter	Test condition	Symbol	Min	Typ.	Max	Unit
Luminous flux	$I_F = 15 \text{ mA}$	$\phi_V$	10	30		mlm
Dominant wavelength	$I_F = 10 \text{ mA}$	$\lambda_d$	562		575	nm
Peak wavelength	$I_F = 10 \text{ mA}$	$\lambda_p$		565		nm
Angle of half intensity	$I_F = 10 \text{ mA}$	$\phi$		$\pm 85$		deg
Forward voltage	$I_F = 20 \text{ mA}$	$V_F$		2.4	3	V
Reverse voltage	$I_R = 10 \mu\text{A}$	$V_R$	6	15		V
Junction capacitance	$V_R = 0, f = 1 \text{ MHz}$	$C_j$		50		pF

## Pure green

### TLVP4200

Parameter	Test condition	Symbol	Min	Typ.	Max	Unit
Luminous flux	$I_F = 15 \text{ mA}$	$\phi_V$	4	10		mlm
Dominant wavelength	$I_F = 10 \text{ mA}$	$\lambda_d$	555		565	nm
Peak wavelength	$I_F = 10 \text{ mA}$	$\lambda_p$		555		nm
Angle of half intensity	$I_F = 10 \text{ mA}$	$\phi$		$\pm 85$		deg
Forward voltage	$I_F = 20 \text{ mA}$	$V_F$		2.4	3	V
Reverse voltage	$I_R = 10 \mu\text{A}$	$V_R$	6	15		V
Junction capacitance	$V_R = 0, f = 1 \text{ MHz}$	$C_j$		50		pF

## Typical Characteristics ( $T_{amb} = 25^\circ\text{C}$ unless otherwise specified)

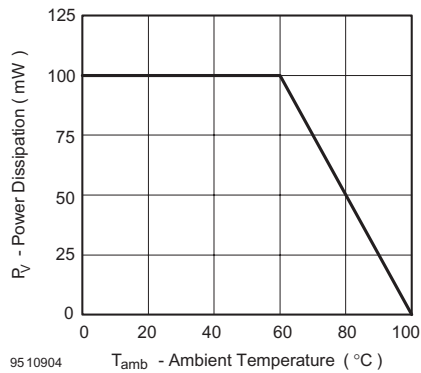

Figure 1. Power Dissipation vs. Ambient Temperature

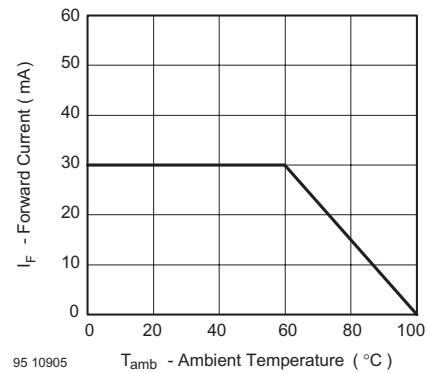

Figure 2. Forward Current vs. Ambient Temperature for InGaN

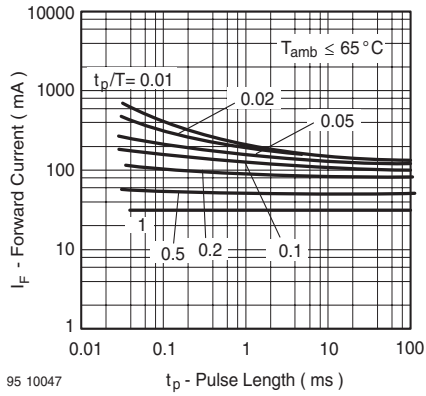

Figure 3. Forward Current vs. Pulse Length

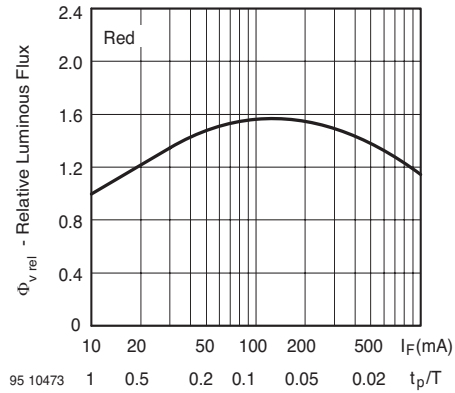

Figure 6. Rel. Luminous Flux vs. Forw. Current/Duty Cycle

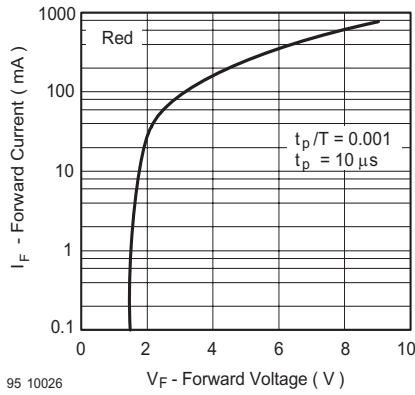

Figure 4. Forward Current vs. Forward Voltage

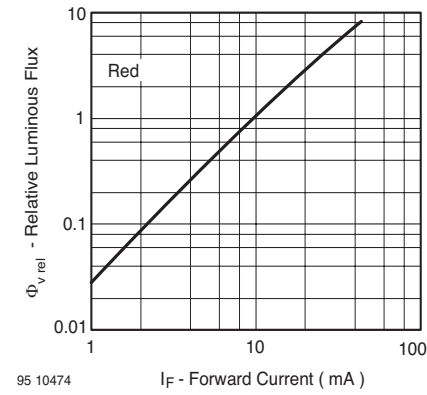

Figure 7. Relative Luminous Flux vs. Forward Current

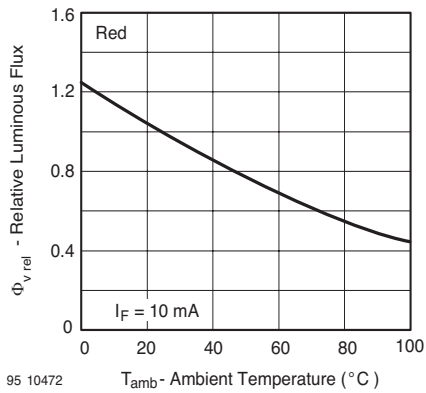

Figure 5. Rel. Luminous Flux vs. Ambient Temperature

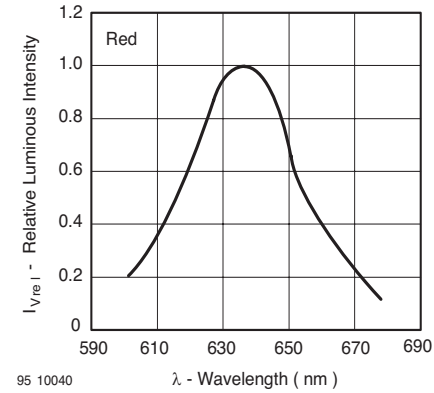

Figure 8. Relative Intensity vs. Wavelength

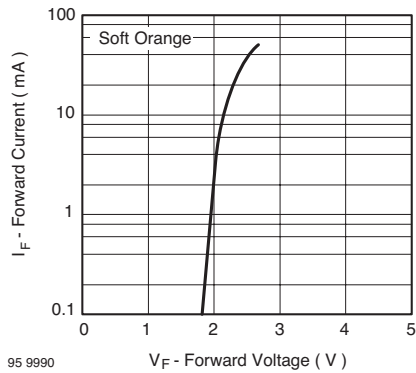

Figure 9. Forward Current vs. Forward Voltage

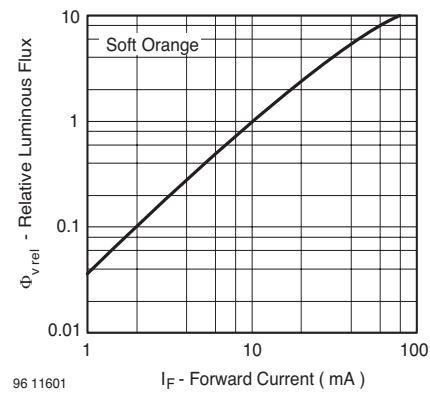

Figure 12. Relative Luminous Flux vs. Forward Current

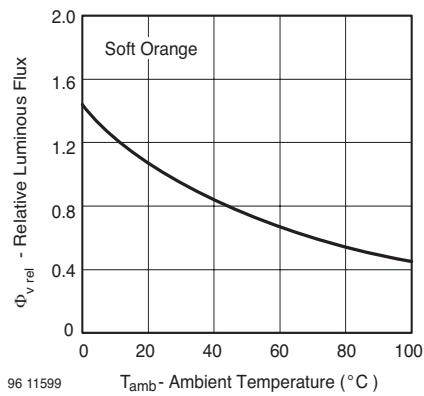

Figure 10. Rel. Luminous Flux vs. Ambient Temperature

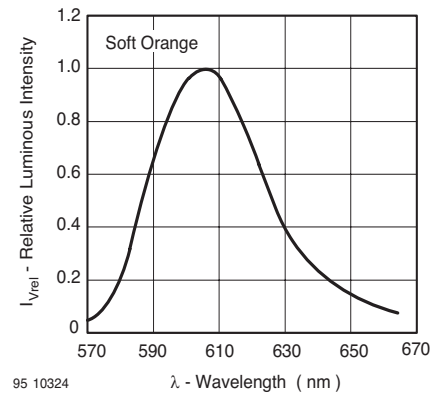

Figure 13. Relative Intensity vs. Wavelength

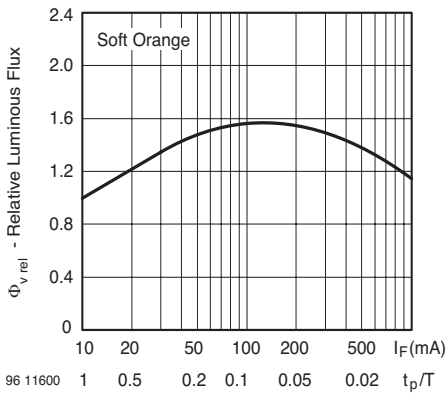

Figure 11. Rel. Luminous Flux vs. Forw. Current/Duty Cycle

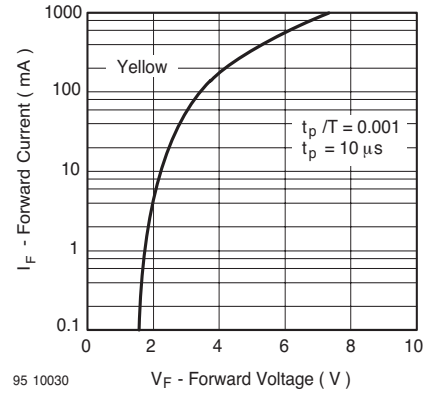
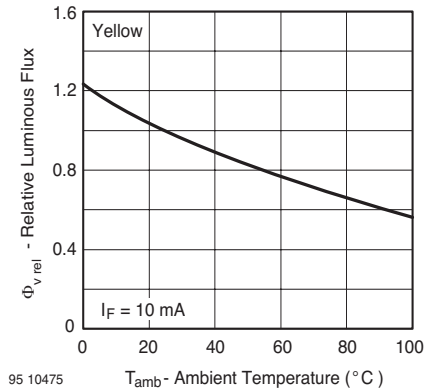
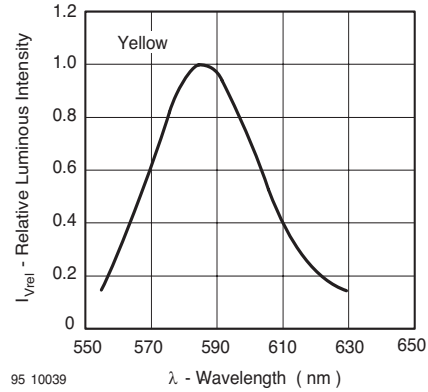

Figure 14. Forward Current vs. Forward Voltage



95 10475

Figure 15. Rel. Luminous Flux vs. Ambient Temperature



95 10039

Figure 18. Relative Intensity vs. Wavelength

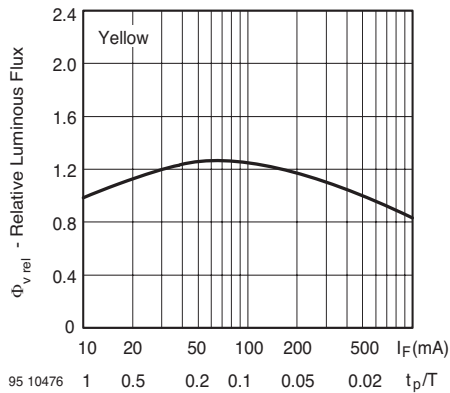

95 10476

Figure 16. Rel. Luminous Flux vs. Forw. Current/Duty Cycle

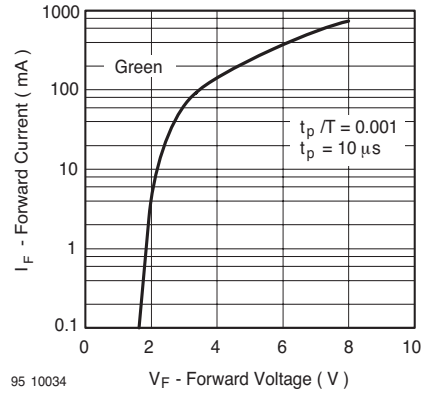

95 10034

Figure 19. Forward Current vs. Forward Voltage

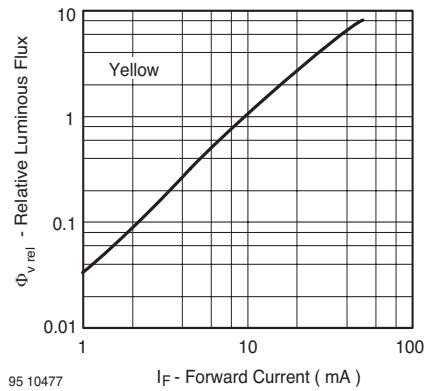

95 10477

Figure 17. Relative Luminous Flux vs. Forward Current

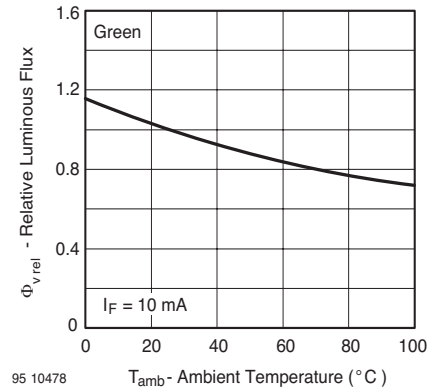

95 10478

Figure 20. Rel. Luminous Flux vs. Ambient Temperature

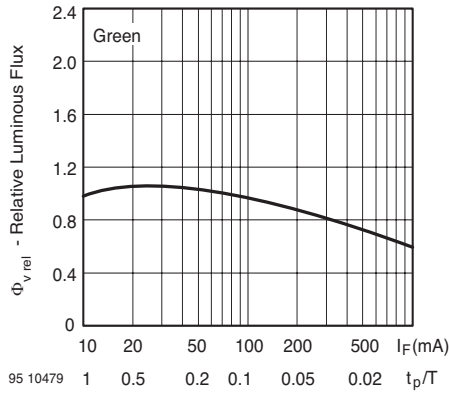

Figure 21. Rel. Luminous Flux vs. Forw. Current/Duty Cycle

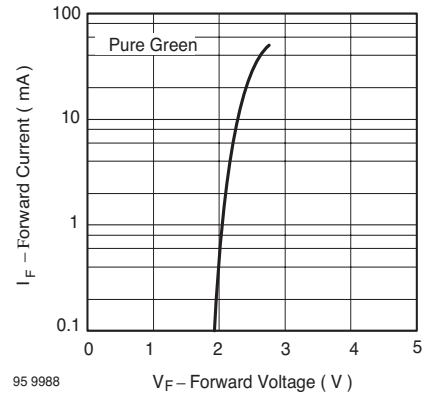

Figure 24. Forward Current vs. Forward Voltage

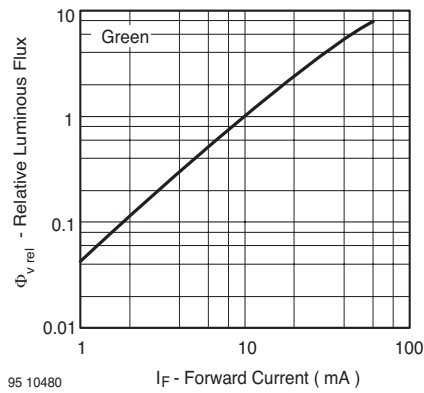

Figure 22. Relative Luminous Flux vs. Forward Current

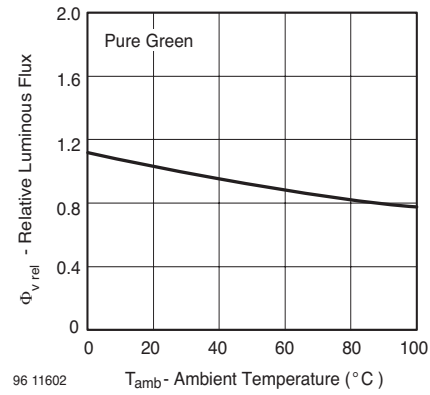

Figure 25. Rel. Luminous Flux vs. Ambient Temperature

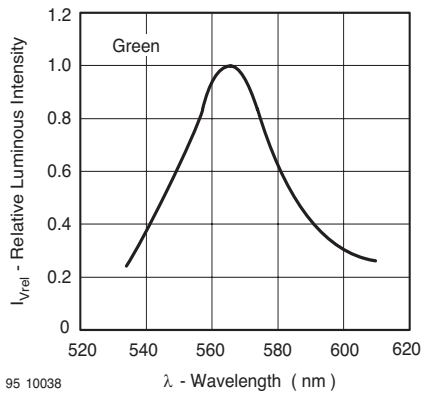

Figure 23. Relative Intensity vs. Wavelength

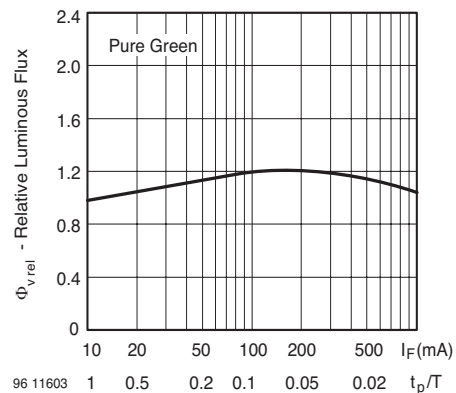

Figure 26. Rel. Luminous Flux vs. Forw. Current/Duty Cycle

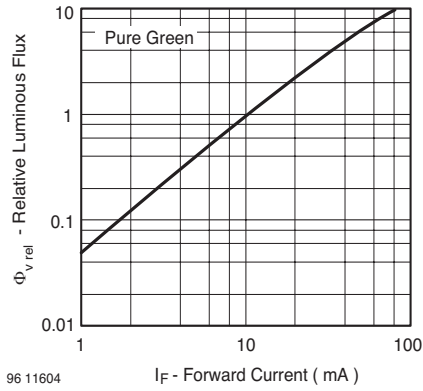

Figure 27. Relative Luminous Flux vs. Forward Current

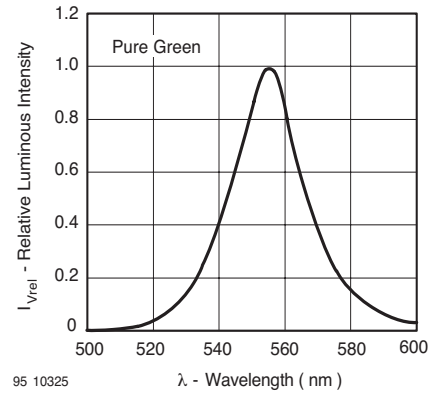

Figure 28. Relative Intensity vs. Wavelength

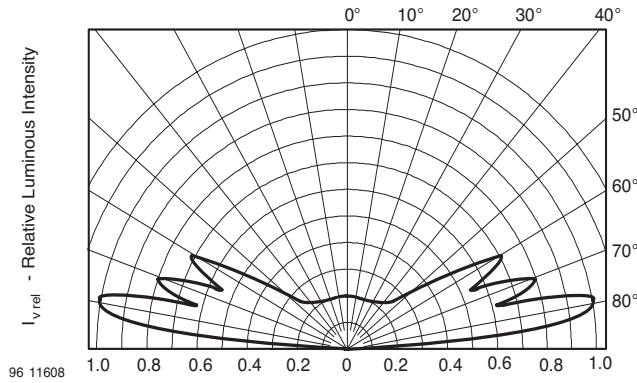
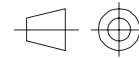
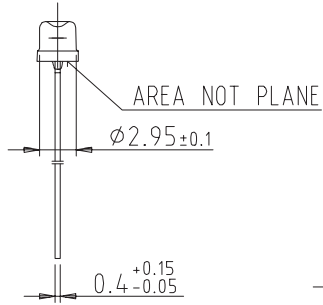
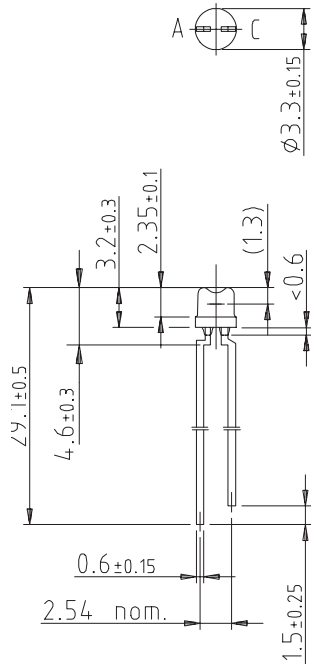

Figure 29. Rel. Luminous Intensity vs. Angular Displacement for 90° Emission Angle



## Package Dimensions in mm



technical drawings  
according to DIN  
specifications

9510954

### Ozone Depleting Substances Policy Statement

It is the policy of **Vishay Semiconductor GmbH** to

1. Meet all present and future national and international statutory requirements.
2. Regularly and continuously improve the performance of our products, processes, distribution and operating systems with respect to their impact on the health and safety of our employees and the public, as well as their impact on the environment.

It is particular concern to control or eliminate releases of those substances into the atmosphere which are known as ozone depleting substances (ODSs).

The Montreal Protocol (1987) and its London Amendments (1990) intend to severely restrict the use of ODSs and forbid their use within the next ten years. Various national and international initiatives are pressing for an earlier ban on these substances.

**Vishay Semiconductor GmbH** has been able to use its policy of continuous improvements to eliminate the use of ODSs listed in the following documents.

1. Annex A, B and list of transitional substances of the Montreal Protocol and the London Amendments respectively
2. Class I and II ozone depleting substances in the Clean Air Act Amendments of 1990 by the Environmental Protection Agency (EPA) in the USA
3. Council Decision 88/540/EEC and 91/690/EEC Annex A, B and C (transitional substances) respectively.

**Vishay Semiconductor GmbH** can certify that our semiconductors are not manufactured with ozone depleting substances and do not contain such substances.

**We reserve the right to make changes to improve technical design  
and may do so without further notice.**

Parameters can vary in different applications. All operating parameters must be validated for each customer application by the customer. Should the buyer use Vishay Semiconductors products for any unintended or unauthorized application, the buyer shall indemnify Vishay Semiconductors against all claims, costs, damages, and expenses, arising out of, directly or indirectly, any claim of personal damage, injury or death associated with such unintended or unauthorized use.

Vishay Semiconductor GmbH, P.O.B. 3535, D-74025 Heilbronn, Germany  
Telephone: 49 (0)7131 67 2831, Fax number: 49 (0)7131 67 2423

This datasheet has been download from:

[www.datasheetcatalog.com](http://www.datasheetcatalog.com)

Datasheets for electronics components.