

320 Watts

SDC Series



- High Power Density
- Single & Dual Outputs
- Up to 700 W Peak Power
- Fan Fail & Power Good Signals
- Low Leakage Current Option
- Fits 1U Applications
- 3 Year Warranty

Specification

Input

Input Voltage	• 90-132 VAC/180-264 VAC, 'A' version, 90-264 VAC, 'P' version
Input Frequency	• 47-63 Hz
Input Current	• 7 A at 90 VAC, 3 A at 230 VAC, 'A' version 4.5 A at 90 VAC, 2 A at 230 VAC, 'P' version
Inrush Current	• Max 70 A at 230 VAC, 35 A at 115 VAC, cold start
Power Factor	• EN61000-3-2 class A, 'A' version >0.9 'P' versions
Earth Leakage Current	• <1.5 mA at 264 VAC, option '-L' 500 μ A on 'A' input version only
Input Protection	• T8 A/250 V fuse, 'A' version T6 A/250 V fuse, 'P' version

Output

Output Voltage	• See tables
Output Voltage Trim	• \pm 5% on V1 (V2 of dual output models will track by same % of adjustment)
Initial Set Accuracy	• \pm 1%
Minimum Load	• 1% on single output models, 10% on both output of dual output models in order to maintain ripple & noise and regulation specifications
Start Up Delay	• 1.5 s max at 120 VAC
Start Up Rise Time	• 50 ms typical
Hold Up Time	• 20 ms min at 80% of full load
Line Regulation	• \pm 0.5%
Load Regulation	• \pm 1% 1-100% load for single outputs, \pm 3% V1, \pm 7% V2 for dual outputs (except AD0548 version: \pm 11% on V2)
Over/Undershoot	• 5% max
Transient Response	• \pm 5% max deviation, recovery to within 1% in 500 μ s for a 50% load change
Ripple & Noise	• 1% pk-pk (see note 3)
Overvoltage Protection	• <130% on V1 recycle AC input to reset
Overtemperature	• Measured internally auto recovery
Overload Protection	• 110-140%
Short Circuit Protection	• Trip & restart, auto recovery
Fan Supply	• 12 V/300 mA, not available on '-F' & '-E' versions with built-in fans
Remote On / Off	• Fitted to 'P' version only

General

Efficiency	• Single output: 5 V: 70%, 12 V: 80%, All other models: >83% at 230 V & full load, Dual Output: >70% at 230 V & full load
Isolation	• 3000 VAC Input to Output, 1500 VAC Input to Ground, 250 VDC Output to Ground
Switching Frequency	• 23 kHz typical single output models, 25 kHz typical dual output models 'A' versions, 60 kHz PFC, 56 kHz PWM 'P' versions
Power Density	• 8.9 W/In ³
Signals	• Fan Fail & Power Good
MTBF	• >100 kHrs to MIL-HDBK-217F, at 25 °C GB

Environmental

Operating Temperature	• 0 °C to +70 °C, derate at 2.5%/°C from +50 °C to +70 °C when force air cooled. 0 °C to +60 °C, derate at 5%/°C from +50 °C to +60 °C when convection cooled.
Storage Temperature	• -20 °C to +85 °C
Operating Humidity	• 5-90%, non-condensing
Cooling	• '-F' & '-E' versions have built-in fans, 5 V single output model requires 22 CFM to meet forced air ratings, all other models require 18 CFM. 'P' version requires 27 CFM on all models
Operating Altitude	• 3000 m
Vibration	• 5-50 Hz, acceleration 7.35 ms ² on 3 axes

EMC & Safety

Emissions	• EN55022 Level B conducted & radiated
Harmonic Currents	• EN61000-3-2 class A EN61000-3-2 class C for loads \geq 30% ('P' versions only)
Voltage Flicker	• EN61000-3-3
ESD Immunity	• EN61000-4-2, level 3 Perf Criteria A
Radiated Immunity	• EN61000-4-3, 3 V/m Perf Criteria A
EFT/Burst	• EN61000-4-4, level 2 Perf Criteria A
Surge	• EN61000-4-5, installation class 3 Perf Criteria A
Conducted Immunity	• EN61000-4-6, 3V Perf Criteria A
Dips & Interruptions	• EN61000-4-11, 30% 10 ms, 60% 100 ms, 100% 5000 ms Perf Criteria A, B, B
Safety Approvals	• UL60950-1, CSA C22.2 No. 60950-1, EN60950-1

Models and Ratings

Output Power		Output 1				Output 2				Model Number	
Forced Air Cooled	Convection Cooled	Voltage	Current			Voltage	Current			Auto Ranging Input ⁽²⁾	Universal Input
			Forced Air	Convection	Peak ⁽¹⁾		Forced Air	Convection	Peak ⁽¹⁾		
225 W	136 W ⁽⁴⁾	5 V	45.00 A	27.28 A ⁽⁵⁾	140.00 A					SDC320AS05 ^{(7)A}	SDC320PS05 ⁽⁷⁾
260 W ⁽⁶⁾	147 W ⁽⁶⁾	9 V	29.10 A ⁽⁵⁾	16.37 A ⁽⁶⁾	77.79 A					SDC320AS09 ⁽⁷⁾	SDC320PS09 ⁽⁷⁾
320 W	180 W	12 V	26.67 A	15.00 A	58.33 A					SDC320AS12 ^{(7)A}	SDC320PS12
320 W	180 W	15 V	21.33 A	12.00 A	46.77 A					SDC320AS15 ^{(7)A}	SDC320PS15 ⁽⁷⁾
320 W	180 W	18 V	17.78 A	10.00 A	38.89 A					SDC320AS18 ⁽⁷⁾	SDC320PS18 ⁽⁷⁾
320 W	180 W	24 V	13.33 A	7.50 A	29.17 A					SDC320AS24 ^{(7)A}	SDC320PS24
320 W	180 W	28 V	11.43 A	6.43 A	25.00 A					SDC320AS28 ⁽⁷⁾	SDC320PS28 ⁽⁷⁾
320 W	180 W	36 V	8.88 A	5.00 A	19.44 A					SDC320AS36	SDC320PS36
320 W	180 W	48 V	6.67 A	3.75 A	14.58 A					SDC320AS48 ^{(7)A}	SDC320PS48
320 W	180 W	54 V	5.93 A	3.33 A	12.96 A					SDC320AS54 ⁽⁷⁾	SDC320PS54 ⁽⁷⁾
320 W	180 W	60 V	5.33 A	3.00 A	11.61 A					SDC320AS60 ⁽⁷⁾	SDC320PS60 ⁽⁷⁾
250 W	125 W	+5 V	30.00 A	15.00 A	36.00 A	+12 V	16.67 A	10.42 A	20.00 A	SDC320AD0512 ⁽⁷⁾	SDC320PD0512 ⁽⁷⁾
250 W	125 W	+5 V	30.00 A	15.00 A	36.00 A	+24 V	8.33 A	5.20 A	10.00 A	SDC320AD0524 ⁽⁷⁾	SDC320PD0524 ⁽⁷⁾
250 W	125 W	+5 V	30.00 A	15.00 A	36.00 A	+48 V	4.16 A	2.60 A	5.00 A	SDC320AD0548 ⁽⁷⁾	SDC320PD0548 ⁽⁷⁾
300 W	150 W	+12 V	16.67 A	12.50 A	20.00 A	+24 V	8.33 A	6.25 A	10.00 A	SDC320AD1224	SDC320PD1224

Notes

1. Peak load can be taken for 500 μs. Average power not to exceed nominal power.
2. Add suffix '-L' to model number for optional 500 μA leakage current ('A' input version only)⁽⁷⁾
3. Ripple & noise is measured using 0.1 μF ceramic capacitor in parallel with 22 μF electrolytic and 20 MHz bandwidth.
4. Convection-cooled rating for SDC320PS05 is 130 W, 26 A.
5. Forced air cooled rating for SDC320PS09 is 320 W, 35.5 A.
6. Convection-cooled rating for SDC320PS09 is 180 W, 20 A.
7. Available for OEM quantities, contact Sales.

† Available from Farnell & element14. See pages 284-290.

^ Available from Newark. See pages 291-296.

Mechanical Options

- Add suffix '-F' to the model number for a top fan cover (forced air cooled ratings apply).
- Add suffix '-E' to the model number for an end fan cover (forced air cooled ratings apply).
- Add suffix '-C' to the model number for a U-channel with vented cover.
For 'A' input models, convection-cooled output power available 125 W for 5 V & 9 V model & 170 W for other single output models. Convection-cooled output power available for 'P' input models is not affected by adding vented cover. Forced air cooled rating is available for 'P' input models with vented cover.
- Add suffix 'D' to the model number for JST connector, not available on SDC320AS05 or SDC320PS05 for OEM quantities, contact Sales.
- If no suffix is added to the model number the unit is a U-channel, convection-cooled ratings apply or external fan cooling required (22 CFM for 5 V model, 18 CFM for all other 'A' models and 27 CFM for all 'P' models).

Mechanical Details

Enclosed with Top Fan ('-F' Option)

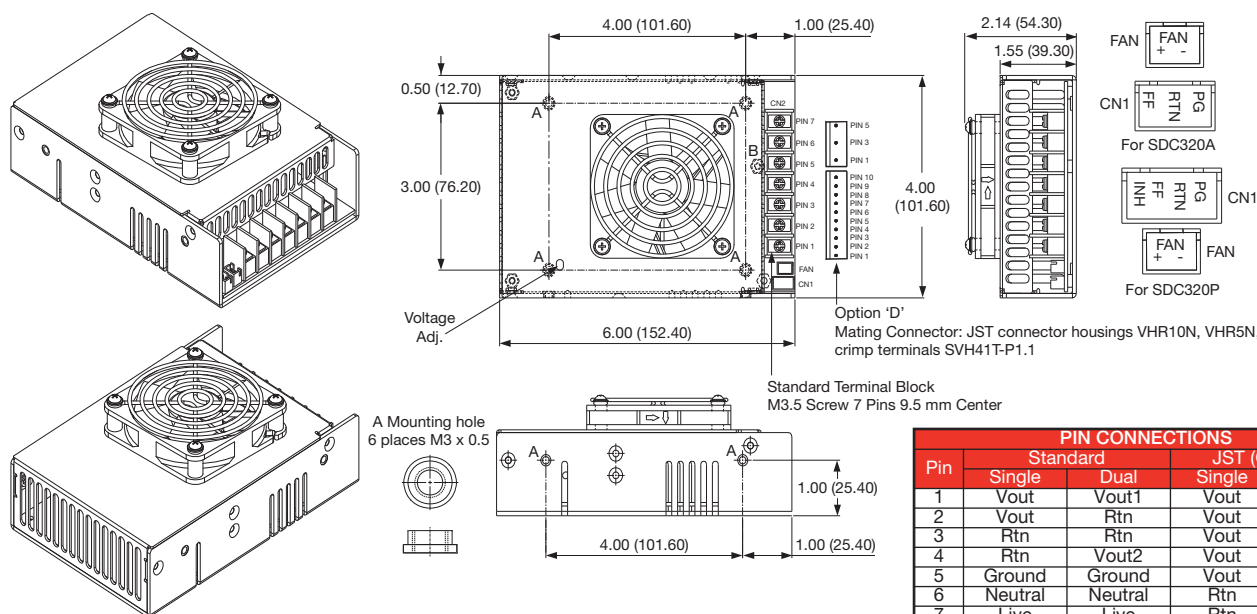

Pin	PIN CONNECTIONS			
	Standard		JST (Option D)	
	Single	Dual	Single	Dual
1	Vout	Vout1	Vout	Vout1
2	Vout	Rtn	Vout	Vout1
3	Rtn	Rtn	Vout	Vout1
4	Rtn	Vout2	Vout	Rtn
5	Ground	Ground	Vout	Rtn
6	Neutral	Neutral	Rtn	Rtn
7	Live	Live	Rtn	Rtn
8			Rtn	Rtn
9			Rtn	Vout2
10			Rtn	Vout2

1			Ground	Ground
3			Neutral	Neutral
5			Live	Live

Signal Connector mating part is JST XHP-3 for SDC320A, JST XHP-4 for SDC320P
Crimp terminals SXH-002T-P0.6
All dimensions are in inches (mm)
Weight: 770 g (1.70 lbs)
Tolerance: ±0.012 in (±0.3 mm)

Max screw terminal torque: 15.7 lbs-in (1.8 Nm)
Max screw mount hole penetration : 0.16 (4.0)



Mechanical Details

Enclosed with End Fan ('-E' Option)

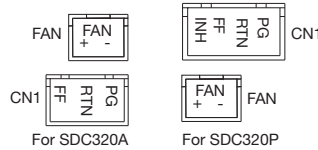
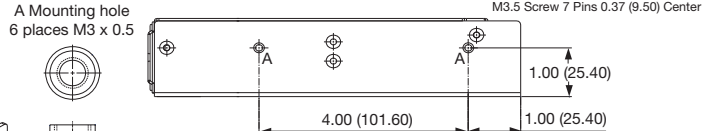
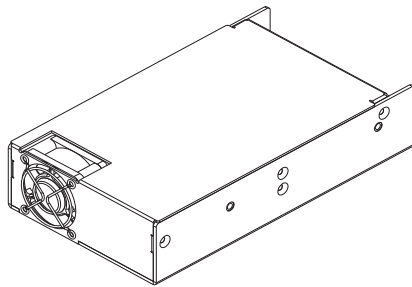
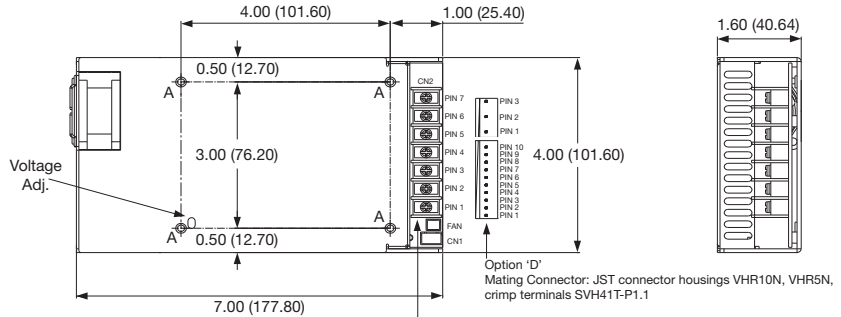
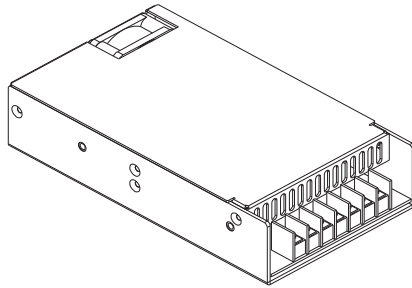

Pin	PIN CONNECTIONS			
	Standard		JST (Option D)	
	Single	Dual	Single	Dual
1	Vout	Vout1	Vout	Vout1
2	Vout	Rtn	Vout	Vout1
3	Rtn	Rtn	Vout	Vout1
4	Rtn	Vout2	Vout	Rtn
5	Ground	Ground	Vout	Rtn
6	Neutral	Neutral	Rtn	Rtn
7	Live	Live	Rtn	Rtn
8			Rtn	Rtn
9			Rtn	Vout2
10			Rtn	Vout2

1			Ground	Ground
3			Neutral	Neutral
5			Live	Live

Signal Connector mating part is JST XHP-3 for SDC320A, JST XHP-4 for SDC320P
Crimp terminals SXH-002T-P0.6

All dimensions are in inches (mm)
Weight: 800 g (1.76 lbs)
Tolerance: ±0.012 in (±0.3 mm)

Max screw terminal torque: 15.7 lbs-in (1.8 Nm)
Max screw mount hole penetration : 0.16 (4.0)

U-Channel

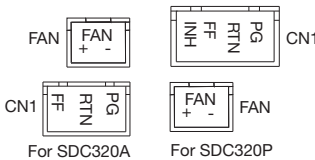
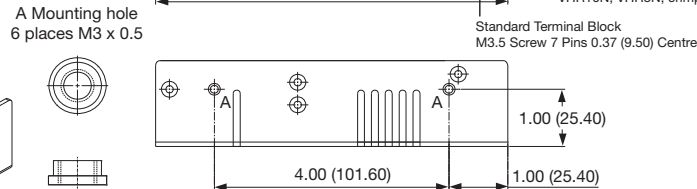
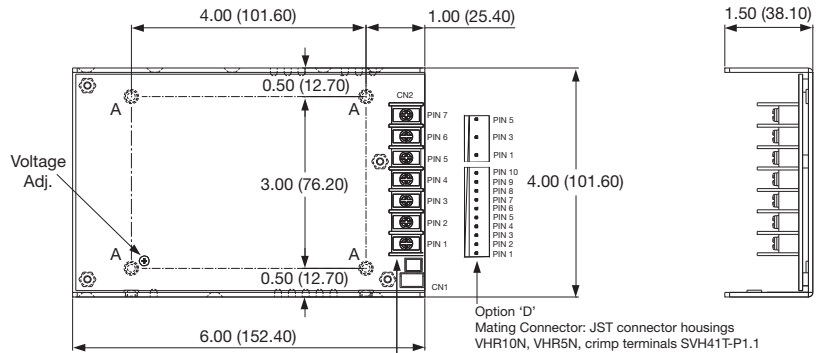
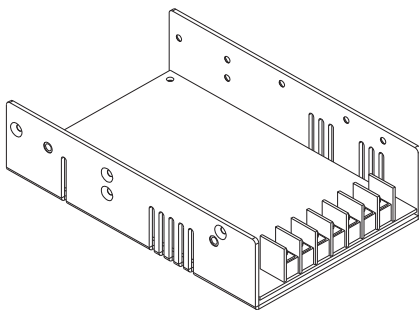

Signal Connector mating part is JST XHP-3 for SDC320A, JST XHP-4 for SDC320P
Fan Connector mating part is JST XHP-2, Crimp terminals SXH-002T-P0.6

All dimensions are in inches (mm)
Weight: 680 g (1.50 lbs)
Tolerance: ±0.012 in (±0.3 mm)

Max screw terminal torque: 15.7 lbs-in (1.8 Nm)
Max screw mount hole penetration : 0.16 (4.0)

Mechanical Details

U-Channel with cover ('-C' Option)

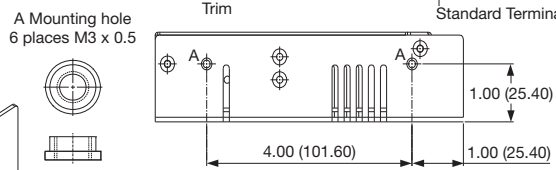
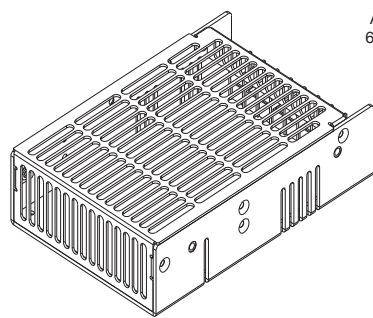
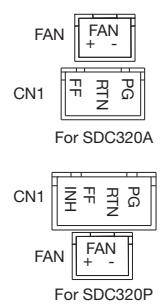
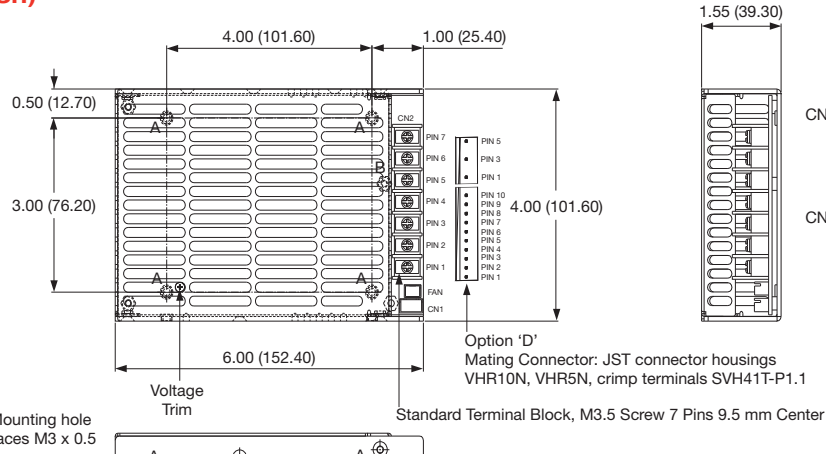
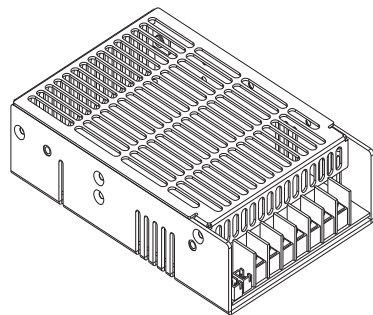

Pin	Standard		JST (Option D)	
	Single	Dual	Single	Dual
1	Vout	Vout1	Vout	Vout1
2	Vout	Rtn	Vout	Vout1
3	Rtn	Rtn	Vout	Vout1
4	Rtn	Vout2	Vout	Rtn
5	Ground	Ground	Vout	Rtn
6	Neutral	Neutral	Rtn	Rtn
7	Live	Live	Rtn	Rtn
8			Rtn	Rtn
9			Rtn	Vout2
10			Rtn	Vout2

1			Ground	Ground
3			Neutral	Neutral
5			Live	Live

Signal Connector mating part is JST XHP-3 for SDC320A, JST XHP-4 for SDC320P
Fan Connector mating part is JST XHP-2, Crimp terminals SXH-002T-P0.6

All dimensions are in inches (mm)
Weight: 720 g (1.59 lbs)
Tolerance: ±0.012 in (±0.3 mm)
Max screw terminal torque: 15.7 lbs-in (1.8 Nm)
Max screw mount hole penetration : 0.16 (4.0)

Application Notes

Power Good

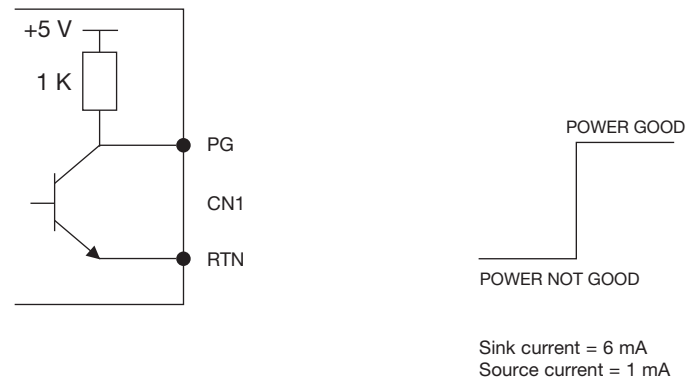

Remote On / Off

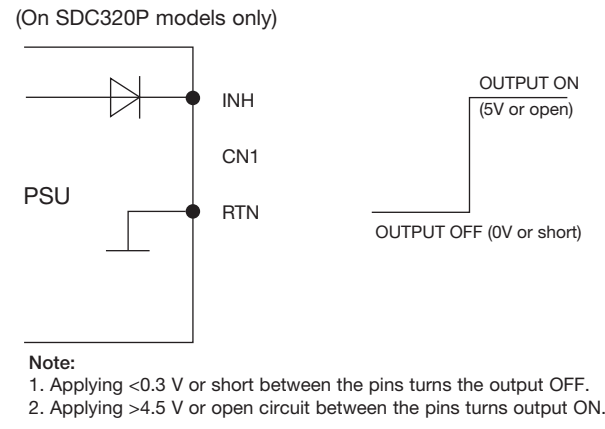

Fan Fail

