

# DRAGONpuck®

## LED Module



### The new OSRAM SYLVANIA DRAGONpuck LED module for spotlighting applications.

With the addition of its new DRAGONpuck LED modules, OSRAM SYLVANIA is rapidly bridging the gap between the requirements of white light illumination and the capabilities of LED technology. These new modules offer bright and intense light for spotlighting applications such as landscape lighting, display shelves, under cabinet lighting, reading lights and other general illumination applications.

The DRAGONpuck LED modules consist of three Golden DRAGON™ hi-flux LEDs mounted on a metal substrate circuit board and an optical lens. The module is more efficient than incandescent or halogen light sources with a similar luminous intensity. It comes pre-wired with polarized wires for easy installation.

In continuing with its leadership in the lighting industry by providing complete system solutions, OSRAM SYLVANIA offers OPTOTRONIC constant current power supplies to operate the new DRAGONpuck modules.

### Application Information

#### Applications

Task lighting – reading lights, under cabinet lighting  
 Accent lighting – cove lighting, outdoor/landscape lighting  
 Shelf lighting  
 Refrigerated and freezer display case lighting  
 Light box, backlit graphics, edge lighting  
 Vehicle cabin lighting – RV, truck, boat, airplane  
 Solar powered installations

- Compact hi-flux LED light source with an on-board optic for spot-lighting applications
- Luminous intensity of up to 285 candelas for white light
- Sleek, innovative light source design for compact fixtures
- Simple assembly to metallic heat-sink surface with an M3x8 screw
- Pre-wired with 7.9 inch polarized cables (red for +, black for -)
- Better efficacy than incandescent or halogen light sources
- Long service life when installed with proper thermal management
- No ultraviolet or infrared radiation
- Dimensions (H x Dia.): 0.48 in X 1.38 in
- Optimal operation with OPTOTRONIC®, constant current power supplies (Literature ordering code ECS052)
- Service life of up to 50,000 hours when temperature at Tc point is maintained at 40°C

### Product Availability

Product	Wattage (W)	Wavelength (nm) Color Temp. (K)	Color
DRAGONpuck/OS/DP3/W2-865	3.6	6500K	White
DRAGONpuck/OS/DP3/W2-854	3.6	5400K	White
DRAGONpuck/OS/DP3/W2-847	3.6	4700K	White
DRAGONpuck/OS/DP3/A1	2.4	617 nm	Red
DRAGONpuck/OS/DP3/Y1	2.4	587 nm	Yellow
DRAGONpuck/OS/DP3/V1	3.6	505 nm	Verde
DRAGONpuck/OS/DP3/B1	3.6	470 nm	Blue

#### Power Supply Information

The DRAGONpuck is presently compatible with the OT9/100-120/350 E (NAED 51525) and the OT9/10-24/350 DIM E (NAED 51526) power supply products. Contact your OSRAM SYLVANIA representative for specific information on these products and possible updates to this list.

## Maximum Ratings For DRAGONpuck® (all colors)

Parameter	Rating
Operating Temperature at Tc-Point	-30...+85°C (-22...+185°F)
Storage Temperature	-30...+85°C (-22...+185°F)
Maximum Allowable Current (dc)	350 mA
Maximum Reverse Voltage	0 V

Notes:

1. Exceeding maximum ratings may damage the LED module and cause potential safety hazards.
2. Elevated operating temperatures can be expected to negatively impact the service life in terms of lumen output.
3. Incorrect wiring (i.e. reverse polarity) with constant current power supplies may damage the LED module.
4. Not intended for use with constant voltage power supplies.

## Dimensions

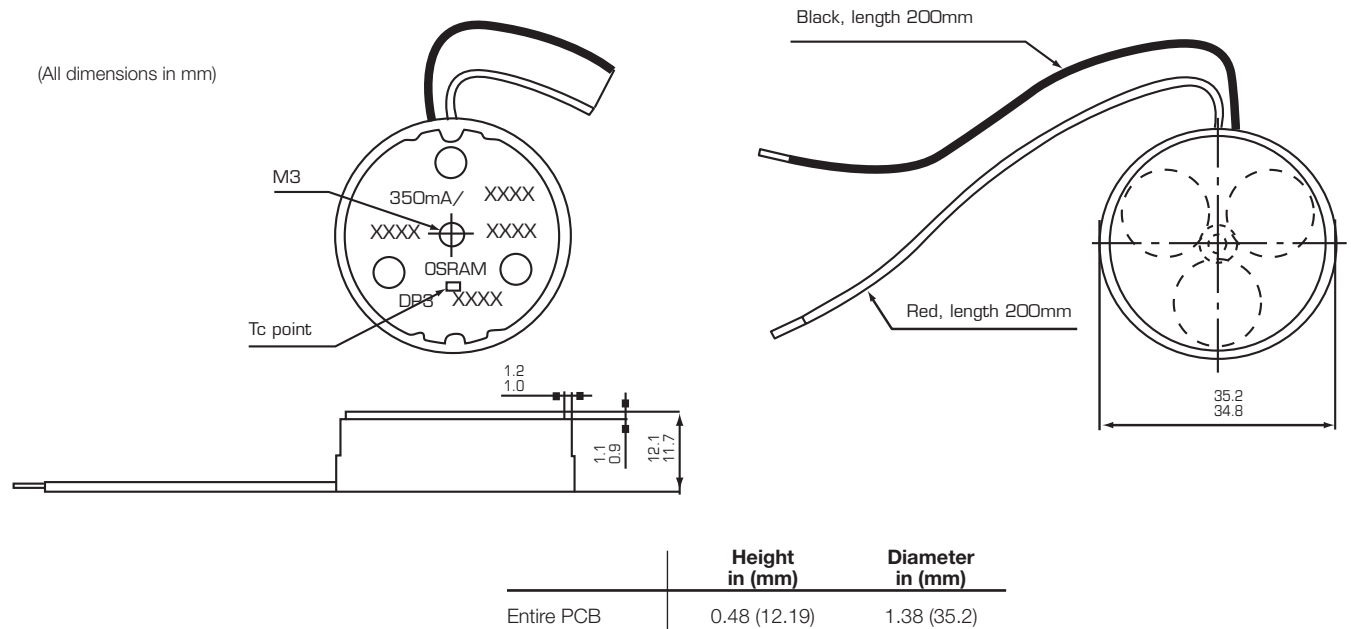

## Safety Information

1. The LED module itself and all its components must not be mechanically stressed.
2. Assembly must not damage or destroy conducting paths on the circuit board.

The LED Module incorporates no protection against short circuits, overload or overheating. Therefore it is absolutely necessary to operate the modules with an electronically stabilized power supply offering protection against the above mentioned safety risks.

**OSRAM OPTOTRONIC power supplies are specifically designed with protection features for safe operation.**

When using power supplies other than OPTOTRONIC the following basic safety features are required in addition to any other application specific concerns and local safety codes:

- Short circuit protection
- Overload protection
- Overheat protection
- Correct output voltage, including consideration for ripple and spikes.

3. Installation of LED modules (with power supplies) needs to be made with regard to all applicable electrical and safety standards. Only qualified personnel should be allowed to perform installations.
4. Correct electrical polarity needs to be observed. Wrong polarity may destroy the module and will result in no light emission.
5. Serial/electrical connection is recommended for 2 (white, green, blue) or 3 (red, yellow) modules. Parallel electrical connection is not recommended. Unbalanced voltage drop can cause hazardous overload and damage the LED module.

- Please ensure that the power supply is of adequate power to operate the total load. For the OT 09/100-120/350E and OT09/10-24/350DIM/E power supplies, the maximum number of DRAGONpuck modules per power supply is 2 modules for the colors white, green and blue and 3 modules for yellow and red.
- Pay attention to standard ESD precautions when installing the module.
- Dimming of the DRAGONpuck is possible using the Pulse Width Modulation (PWM) functionality of the OPTOTRONIC OT 09/10-24/350 DIM/E. Dimming through the regulation of current amplitude will result in a spectral color shift.
- Damage by corrosion will not be honored as a materials defect claim. It is the user's responsibility to provide suitable protection against corrosive agents such as moisture and condensation and other harmful elements.
- Modules may be hot to touch. Use appropriate caution.

## Assembly Information

- The mounting of the module is facilitated by means of a M3x8 (8mm) screw which fits to a threaded hole in the rear of the DRAGONpuck housing. The length of the screw depends on the thickness of the heat sink used.
- The module should be in good thermal contact with the designed metallic mounting surface. Use of an appropriate heat sink compound is recommended to eliminate air gaps.
- To obtain maximum LED-lifetime please read carefully the recommended procedures concerning thermal management in our application note "Lifetime of LED-modules" before beginning construction of luminaries. This application note is available from your OSRAM SYLVANIA representative.

## Application Notes

- Module is intended for use with 350 mA constant current drive condition as is provided by the OT9/100-120/350 and OT9/10-24/350 DIM E (see PIB ECS052 for details). The module is not intended for use with constant voltage power supplies, including other OSRAM LED power supplies.
- Installation of the DRAGONpuck must include provision for thermal management to avoid premature failure of the product and to obtain expected service life. Service life (i.e. lumen depreciation) is primarily a function of LED temperature which is to be monitored on the circuit board at the designated "Tc-Point".
- There is no exact installation prescription to obtaining an appropriate Tc-Point temperature because every fixture design is different. In general, the DRAGONpuck module should be mounted to a clean, flat metal surface which has enough surface area to transfer the heat from the module to the surrounding air. The metal surface can be part of a conventional finned heat sink or can be part of the mass of the fixture itself.
- Concerning fixture design, it is important to understand that once heat is transferred to a "heat sink", that heat must still be allowed to escape the "system". A heat sink transferring the thermal energy to the inside of an enclosed cavity may ultimately be of little use.
- The fixture makers' strategy should be to design a prototype fixture and test that fixture in an appropriate ambient environment while monitoring the temperature at the Tc-Point which should be allowed enough time to reach thermal equilibrium. In the end, the heat sink areas from the chart below only represent a starting point for initial design work while the Tc-Point temperature serves as the empirical test of proper thermal management. Tc-Point temperature can be measured with a standard thermocouple in direct contact with the circuit board at the Tc-Point or by use of ML4C Series non-reversible OMEGALABELS ([www.omega.com](http://www.omega.com)) or equivalent.

## Ordering and Specification Information

Item Number	Ordering Abbreviation	Color	Number of LEDs	Current (mA)*	Power (W)*	Radiance Angle (°)*	Wavelength(nm) Color Temp (K)*	Lum. Intensity (cd)*
70108	DRAGONpuck/OS/DP3/W2-865	White	3	350	3.6	20	6500K	285
70107	DRAGONpuck/OS/DP3/W2-854	White	3	350	3.6	20	5400K	285
70120	DRAGONpuck/OS/DP3/W2-847	White	3	350	3.6	20	4700K	285
70121	DRAGONpuck/OS/DP3/A1	Red	3	350	2.4	16	617 nm	215
70124	DRAGONpuck/OS/DP3/Y1	Yellow	3	350	2.4	16	587 nm	215
70123	DRAGONpuck/OS/DP3/V1	Verde	3	350	3.6	16	505 nm	285
70122	DRAGONpuck/OS/DP3/B1	Blue	3	350	3.6	16	470 nm	100

\*All data are related to the entire module.

Due to the special conditions of the manufacturing processes of LED, the typical data of technical parameters can only reflect statistical figures and do not necessarily correspond to the actual parameters of each single product which could differ from the typical data.

## Power Supply Ordering Information

OPTOTRONIC® OT9/100 – 120/350 E or OT9/10-24/350 DIM E

LED Item Number	Color	No. of Modules per Supply
70108	White	2
70107	White	2
70120	White	2
70121	Red	3
70124	Yellow	3
70123	Verde	2
70122	Blue	2

## Ordering Guide

DRAGONpuck	/	OS	/	DP3	/	W2-865
DRAGONpuck		OSRAM		ID number		Color code- Color Temperature W2-865= White, 6500 K W2-854= White, 5400 K W2-847= White, 4700 K A1= Red Y1= Yellow V1= Verde B1= Blue

OSRAM SYLVANIA  
National Customer  
Service and Sales Center  
18725 N. Union Street  
Westfield, IN 46074

### Industrial & Commercial

Phone: 1-800-255-5042  
Fax: 1-800-255-5043

### National Accounts

Phone: 1-800-562-4671  
Fax: 1-800-562-4674

### OEM/Specialty Markets

Phone: 1-800-762-7191  
Fax: 1-800-762-7192

### Display/Optic

Phone: 1-888-677-2627  
Fax: 1-800-762-7192

In Canada  
OSRAM SYLVANIA LTD.  
Headquarters  
2001 Drew Road  
Mississauga, ON L5S 1S4

### Industrial & Commercial

Phone: 1-800-263-2852  
Fax: 1-800-667-6772

### Special Markets

Phone: 1-800-265-2852  
Fax: 1-800-667-6772

Visit our website: [www.sylvania.com](http://www.sylvania.com)

GoldenDRAGON is a registered trademark of OSRAM Opto Semiconductors.  
OSRAM is a registered trademark of OSRAM GmbH.  
OPTOTRONIC is a registered trademark of OSRAM GmbH used under license.  
DRAGONpuck and SYLVANIA are registered trademarks of OSRAM SYLVANIA Inc.