

Luxeon™ V Emitter

power light source

Technical Data DS34

Luxeon™ is a revolutionary, energy efficient and ultra compact new light source, combining the lifetime and reliability advantages of Light Emitting Diodes with the brightness of conventional lighting.

Luxeon Emitters give you total design freedom and unmatched brightness, creating a new world of light.

The Luxeon V offers extreme luminous density, providing lumens per package of 4X a Luxeon or up to 50X that of alternative solid state light sources creating new opportunities for solid state lighting to displace conventional lighting technologies.

Luxeon V Emitters can be purchased in reels for high volume assembly. For high volume applications, custom Luxeon power light source designs are available upon request to meet your specific needs.



Luxeon V Emitter is available in green, blue, royal blue and cyan.

Features

- Highest Flux per LED in the world – 4X the Flux of a comparable Luxeon and up to 50X the Flux of standard through hole LEDs
- Extreme Luminous Density – 20X the lm/mm^2 of a standard through hole LED
- Very long operating life (up to 100k hours)
- Available in Green, Blue, Royal Blue and Cyan
- Lambertian or Side Emitting radiation pattern
- More Energy Efficient than Incandescent and most Halogen lamps
- Low voltage DC operated
- Cool beam, safe to the touch
- Instant light (less than 100 ns)
- Fully dimmable
- No UV
- Superior ESD protection

Typical Applications

- Portable (flashlight, bicycle)
- Architectural Detail Lighting
- Decorative
- Fiber Optic Alternative
- Medical Applications
- Power Signaling / Airfield / Taxiway Lighting
- Edge-Lit Signs (Exit, Point Of Sale)
- LCD Backlights / Light Guides

Mechanical Dimensions

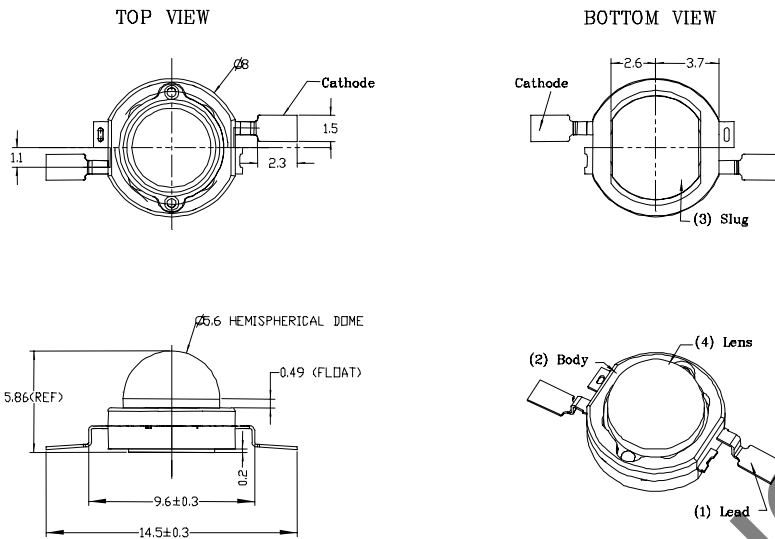

Lambertian

Notes:

1. The anode side of the device is denoted by a hole in the lead frame. Electrical insulation between the case and the board is required – slug of device is not electrically neutral. Do not electrically connect either the anode or cathode to the slug.
2. Drawings not to scale.
3. All dimensions are in millimeters.
4. All dimensions without tolerances are for reference only.

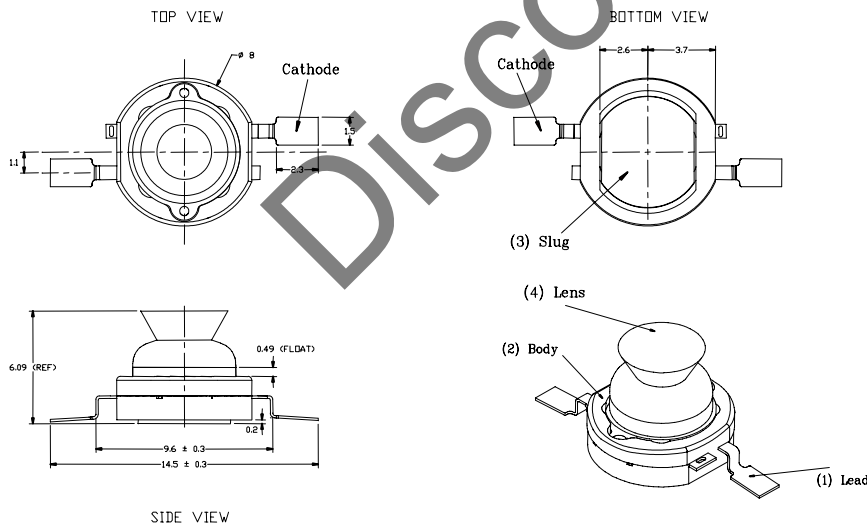

Side Emitting

Notes:

1. The anode side of the device is denoted by a hole in the lead frame. Electrical insulation between the case and the board is required – slug of device is not electrically neutral. Do not electrically connect either the anode or cathode to the slug.
2. Caution must be used in handling this device to avoid damage to the lens surfaces that will reduce optical efficiency.
3. Drawings not to scale.
4. All dimensions are in millimeters.
5. All dimensions without tolerances are for reference only.

Flux Characteristics at 700mA, Junction Temperature, $T_J = 25^\circ\text{C}$

COLOR	LUXEON V EMITTER	MINIMUM LUMINOUS FLUX (lm) OR RADIOMETRIC POWER (mW)	TYPICAL LUMINOUS FLUX (lm) OR RADIOMETRIC POWER (mW)	RADIATION PATTERN
		$\Phi_V^{[1,2]}$	$\Phi_V^{[2]}$	
GREEN	LXHL-PMO2	67.2	160	LAMBERTIAN
CYAN	LXHL-PEO2	67.2	160	
BLUE ^[3]	LXHL-PBO2	23.5	48	
ROYAL BLUE ^[4]	LXHL-PRO2	275 mW	700 mW	
GREEN	LXHL-DMO2	67.2	145	SIDE EMITTING
CYAN	LXHL-DEO2	67.2	145	
BLUE ^[3]	LXHL-DBO2	23.5	43	
ROYAL BLUE ^[4]	LXHL-DRO2	275 mW	630 mW	

Notes:

1. Minimum luminous flux or radiometric power performance guaranteed within published operating conditions. Lumileds maintains a tolerance of $\pm 10\%$ on flux and power measurements.
2. Luxeon types with even higher luminous flux levels will become available in the future. Please consult your Lumileds Authorized Distributor or Lumileds sales representative for more information.
3. Minimum flux value for 470 nm devices. Due to the CIE eye response curve in the short blue wavelength range, the minimum luminous flux will vary over the Lumileds' blue color range. Luminous flux will vary from a minimum of 18.1 lm at 460 nm to a typical of 80 lm at 480 nm due to this effect. Although the luminous power efficiency is lower in the short blue wavelength range, radiometric power efficiency increases as wavelength decreases. For more information, consult the Luxeon Design Guide, available upon request.
4. Royal Blue product is binned by radiometric power and peak wavelength rather than photometric lumens and dominant wavelength.

Electrical Characteristics at 700mA, Junction Temperature, $T_J = 25^\circ\text{C}$

COLOR	FORWARD VOLTAGE V_f (V) ^[1]			DYNAMIC RESISTANCE ^[2] (Ω) R_D	TEMPERATURE COEFFICIENT OF FORWARD VOLTAGE ^[3] (mV/ $^\circ\text{C}$) $\Delta V_f / \Delta T_J$	THERMAL RESISTANCE, JUNCTION TO CASE ($^\circ\text{C/W}$) $R_{\theta JC}$
	MIN.	TYP.	MAX.			
GREEN	5.43	6.84	8.31	1.0	-4.0	8
CYAN	5.43	6.84	8.31	1.0	-4.0	8
BLUE	5.43	6.84	8.31	1.0	-4.0	8
ROYAL BLUE	5.43	6.84	8.31	1.0	-4.0	8

Notes:

1. Lumileds maintains a tolerance of $\pm 0.06\text{V}$ on forward voltage measurements.
2. Dynamic resistance is the inverse of the slope in linear forward voltage model for LEDs. See Figure 3.
3. Measured between $25^\circ\text{C} \leq T_J \leq 110^\circ\text{C}$ at $I_f = 700\text{mA}$.

Optical Characteristics at 700mA, Junction Temperature, $T_J = 25^\circ\text{C}$

RADIATION PATTERN	COLOR	DOMINANT WAVELENGTH ⁽¹⁾ λ_D OR PEAK WAVELENGTH ⁽²⁾ λ_P			SPECTRAL HALF- WIDTH ⁽³⁾ (NM) $\Delta\lambda_{1/2}$	TEMP COEFFICIENT OF DOMINANT WAVELENGTH (NM/ $^\circ\text{C}$) $\Delta\lambda_D/\Delta T_J$	TOTAL INCLUDED ANGLE ⁽⁴⁾ (DEGREES) $\theta_{0.90V}$	VIEWING ANGLE ⁽⁵⁾ (DEGREES) $2\theta_{1/2}$
		MIN.	TYP.	MAX.				
		LAMBERTIAN	GREEN	520 NM				
	CYAN	490 NM	505 NM	520 NM	30	0.04	150	150
	BLUE	460 NM	470 NM	490 NM	25	0.04	150	150
	ROYAL BLUE ⁽²⁾	440 NM	455 NM	460 NM	20	0.04	150	150

Optical Characteristics at 700mA, Junction Temperature, $T_J = 25^\circ\text{C}$, Continued

RADIATION PATTERN	COLOR	DOMINANT WAVELENGTH ⁽¹⁾ λ_D OR PEAK WAVELENGTH ⁽²⁾ λ_P			SPECTRAL HALF- WIDTH ⁽³⁾ (NM) $\Delta\lambda_{1/2}$	TEMP COEFFICIENT OF DOMINANT WAVELENGTH (NM/ $^\circ\text{C}$) $\Delta\lambda_D/\Delta T_J$	TYPICAL TOTAL FLUX PERCENT WITHIN FIRST 45 [°] CUM Φ_{45}	TYPICAL ANGLE OF OFF AXIS PEAK INTENSITY ⁽⁷⁾ θ_{PEAK}
		MIN.	TYP.	MAX.				
		SIDE EMITTING	GREEN	520 NM				
	CYAN	490 NM	505 NM	520 NM	30	0.04	<30%	75° - 85°
	BLUE	460 NM	470 NM	490 NM	25	0.04	<30%	75° - 85°
	ROYAL BLUE ⁽²⁾	440 NM	455 NM	460 NM	20	0.04	<30%	75° - 85°

Absolute Maximum Ratings

PARAMETER	GREEN/CYAN/ BLUE/ROYAL BLUE
DC FORWARD CURRENT (mA) ⁽¹⁾	700
PEAK PULSED FORWARD CURRENT (mA)	1000
AVERAGE FORWARD CURRENT (mA)	700
ESD SENSITIVITY ⁽²⁾	$\pm 16,000V$ HBM
LED JUNCTION TEMPERATURE ($^\circ\text{C}$)	135
STORAGE TEMPERATURE ($^\circ\text{C}$)	-40 to +120
SOLDERING TEMPERATURE ($^\circ\text{C}$) ⁽³⁾	260 FOR 5 SECONDS MAX

Notes: (for both optical tables)

- Dominant wavelength is derived from the CIE 1931 Chromaticity diagram and represents the perceived color. Lumileds maintains a tolerance of $\pm 0.5\text{nm}$ for dominant wavelength measurements.
- Royal Blue product is binned by radiometric power and peak wavelength rather than photometric lumens and dominant wavelength. Lumileds maintains a tolerance of $\pm 2\text{nm}$ for peak wavelength measurements.
- Spectral width at $\frac{1}{2}$ of the peak intensity.
- Total angle at which 90% of total luminous flux is captured.
- $\theta_{1/2}$ is the off axis angle from lamp centerline where the luminous intensity is $\frac{1}{2}$ of the peak value.
- Cumulative flux percent within $\pm 45^\circ$ from optical axis.
- Off axis angle from lamp centerline where the luminous intensity reaches peak off axis value. On axis peak may be higher than off axis peak.
- All products built with Indium Gallium Nitride (InGaN).
- Blue and Royal Blue power light sources represented here are IEC825 Class 2 for eye safety.

Notes:

- Proper current derating must be observed to maintain junction temperature below the maximum. For more information, consult the Luxeon Design Guide, available upon request.
- LEDs are not designed to be driven in reverse bias. Please consult Lumileds' Application Brief AB11 for further information.
- Measured at leads, during lead soldering and slug attach, body temperature must not exceed 120°C . Luxeon emitters cannot be soldered by general IR or Vapor-phase reflow, nor by wave soldering. Lead soldering is limited to selective heating of the leads, such as by hot-bar reflow, fiber focussed IR, or hand soldering. The package back plane (slug) may not be attached by soldering, but rather with a thermally conductive adhesive. Electrical insulation between the slug and the board is required. Please consult Lumileds' Application Brief AB10 on Luxeon Emitter Assembly Information for further details on assembly methods.

Wavelength Characteristics, $T_J = 25^\circ\text{C}$

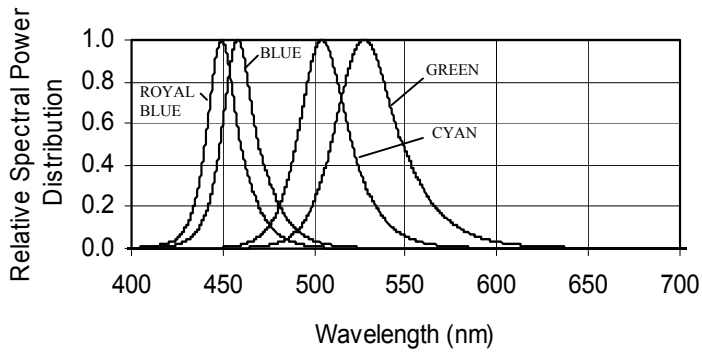

Figure 1.
Relative Intensity vs. Wavelength.

Light Output Characteristics

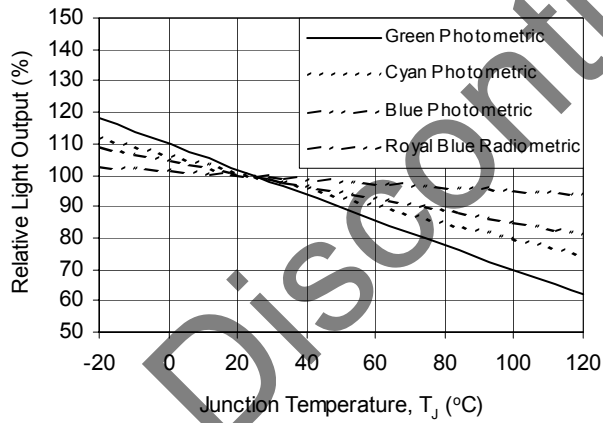
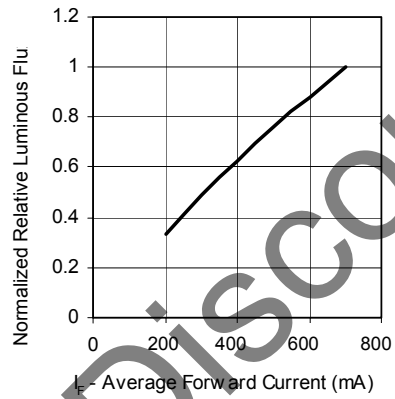
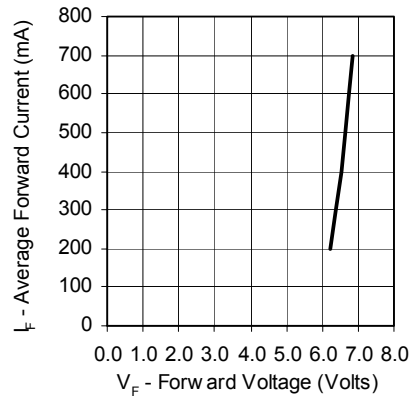

Figure 2.
Relative Light Output vs. Junction Temperature.

Forward Current Characteristics, $T_J = 25^\circ\text{C}$



Note:

Driving these high power devices at currents less than the test conditions may produce unpredictable results and may be subject to variation in performance. Pulse width modulation (PWM) is recommended for dimming effects.

Figure 3.
Forward Current vs. Forward Voltage.

Figure 4.
Relative Luminous Flux vs. Forward Current at $T_J = 25^\circ\text{C}$ maintained.

Current Derating Curve

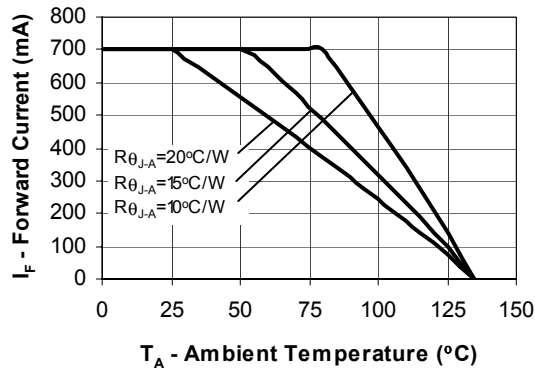

Note:

Additional heatsinking is required, even for extremely brief periods. Please consult AB05, Luxeon Thermal Design Guide, for additional information.

Figure 5.
Maximum Forward Current vs. Ambient Temperature. Derating based on $T_{JMAX} = 135^\circ\text{C}$.

Representative Typical Spatial Radiation Pattern

Lambertian Radiation Pattern

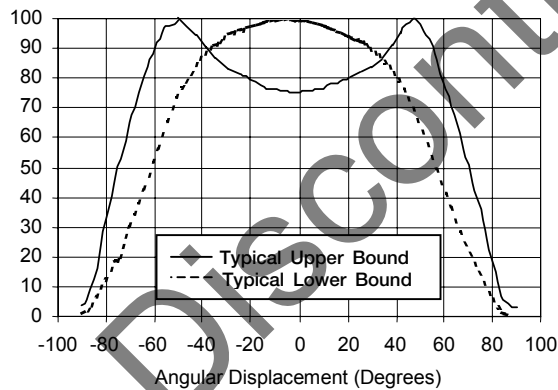

Figure 6.
Representative Typical Spatial Radiation Pattern for Luxeon V Emitter.

Side Emitting Radiation Pattern

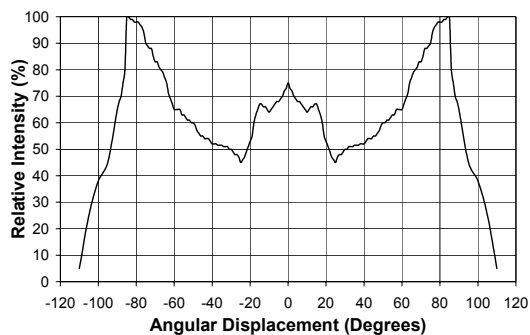

Figure 7.
Representative Typical Spatial Radiation Pattern for Luxeon V Emitter.

Emitter Reel Packaging

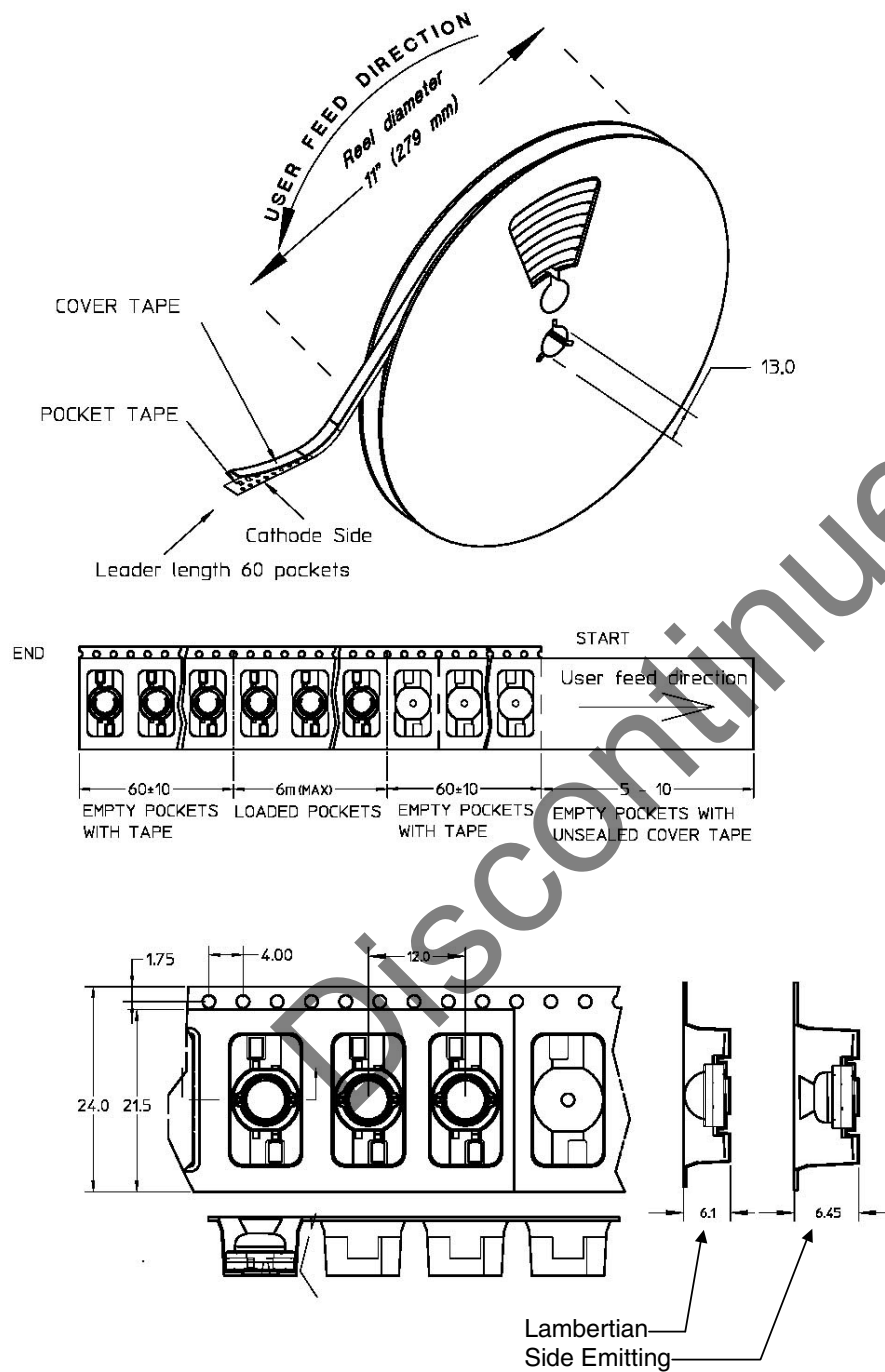

Figure 8. Reel dimensions and orientation.

Figure 9. Tape dimensions for Lambertian and Side Emitting radiation patterns.

Notes:

1. Luxeon emitters should be picked up by the body (not the lens) during placement. The inner diameter of the pick-up collet should be greater than or equal to 6.5 mm. Please consult Lumileds' Application Brief AB10 on Luxeon Emitter assembly information for further details on assembly methods.
2. Drawings not to scale.
3. All dimensions are in millimeters.
4. All dimensions without tolerances are for reference only.

About Luxeon



Luxeon is the new world of solid state lighting (LED) technology. Luxeon Power Light Source Solutions offer huge advantages over conventional lighting and huge advantages over other LED solutions. Luxeon enables partners to create and market products that, until now, were impossible to create. This means the opportunity to create products with a clear competitive advantage in the market. Products that are smaller, lighter, sleeker, cooler, and brighter. Products that are more fun to use, more efficient, and more environmentally conscious than ever before possible!

L U X E  N TM

Company Information

Luxeon is developed, manufactured and marketed by Lumileds Lighting, LLC. Lumileds is a world-class supplier of Light Emitting Diodes (LEDs) producing billions of LEDs annually. Lumileds is a fully integrated supplier, producing core LED material in all three base colors (Red, Green, Blue) and White. Lumileds has R&D development centers in San Jose, California and Best, The Netherlands. Production capabilities in San Jose, California and Malaysia.

Lumileds is pioneering the high-flux LED technology and bridging the gap between solid state LED technology and the lighting world. Lumileds is absolutely dedicated to bringing the best and brightest LED technology to enable new applications and markets in the Lighting world.

LUMILEDS TM
LIGHT FROM SILICON VALLEY

Lumileds may make process or materials changes affecting the performance or other characteristics of Luxeon. These products supplied after such change will continue to meet published specifications, but may not be identical to products supplied as samples or under prior orders.

LUMILEDS

www.luxeon.com
www.lumileds.com

For technical assistance or the location of your nearest Lumileds sales office, call:

Worldwide:
+1 408-435-6044
US Toll free: 877-298-9455
Europe: +31 499 339 439
Asia: +65 6248 4759
Japan: +81 (426) 60 8532
Fax: 408-435-6855
Email us at info@lumileds.com

©2003 Lumileds Lighting U.S. LLC. All rights reserved. Lumileds Lighting is a joint venture between Agilent Technologies and Philips Lighting. Luxeon is a trademark of Lumileds Lighting, Inc. Product specifications are subject to change without notice.

Lumileds Lighting, LLC
370 West Trimble Road
San Jose, CA 95131