

LED Driver

LDU Series



- Constant Current Output
- LED Drive Current up to 1000 mA
- LED Strings from 2 V to 57 V
- PWM & Analog Dimming Control
- High Efficiency – up to 95%
- Open or Short Circuit LED Protection
- 3 Year Warranty

Specification

Input

Input Voltage	• LDU08 & 24: 7-30 VDC LDU48: 7-60 VDC
Input Filter	• Capacitor
Input Surge	• LDU08 & 24: 40 VDC for 0.5 s LDU48: 65 VDC for 0.5 s

Output

Output Voltage	• See tables (V_{in} must be at least 2 V greater than V_{out})
Output Current	• See tables
Output Current Trim	• 25-100%
Output Current Accuracy	• LDU08: $\pm 6.0\%$ max LDU24: $\pm 8.0\%$ max LDU48: $\pm 8.0\%$ max
Ripple & Noise	• LDU08: 200 mV pk-pk max LDU24: 250 mV pk-pk max (except 1000 mA units: 300 mV pk-pk max) LDU48: See tables measured with 20 MHz bandwidth
Short Circuit Protection	• Current is limited to the rated output
Temperature Coefficient	• LDU08: $\pm 0.03\%/^{\circ}\text{C}$ max LDU24: $\pm 0.08\%/^{\circ}\text{C}$ max LDU48: $\pm 0.03\%/^{\circ}\text{C}$ max
Remote On/Off	• On = 0.3-1.25 V or open circuit Off = ≤ 0.15 V (applied to control pin) LDU08 & 24: Quiescent input current is 25 μA max, LDU48: Quiescent input current is 100 μA max
Remote On/Off Signal Current	• 1 mA max

Dimming

PWM

Output Current Range	• 25% to 100%
Operating Frequency	• 1 kHz max
On Time	• 200 ns min
Off Time	• 200 ns min
Amplitude	• 1.25 V max

DC Voltage Control

Output Current Range	• 25% to 100%
Control Input	• 0.3 to 1.25 V max

Variable Resistor

Output Current Range	• 25% to 100%
----------------------	---------------

General

Efficiency	• See tables
Switching Frequency	• LDU08: 40-380 kHz variable LDU24: 50-330 kHz variable LDU48: 20-500 kHz variable
MTBF	• LDU08: >1.6 Mhrs LDU24: >1.6 Mhrs LDU48: >950 Khrs to MIL-HDBK-217F at 25 $^{\circ}\text{C}$, GB

Environmental

Operating Temperature	• LDU08: -40 $^{\circ}\text{C}$ to +85 $^{\circ}\text{C}$, LDU24: -40 $^{\circ}\text{C}$ to +85 $^{\circ}\text{C}$, LDU24 1000 mA unit: -40 $^{\circ}\text{C}$ to +70 $^{\circ}\text{C}$, LDU48: See derating curves
Case Temperature	• LDU08 & 24: +100 $^{\circ}\text{C}$ max LDU48: +110 $^{\circ}\text{C}$ max
Storage Temperature	• -40 $^{\circ}\text{C}$ to +125 $^{\circ}\text{C}$
Humidity	• Up to 95%, non-condensing
Thermal Impedance	• 35-50 $^{\circ}\text{C}/\text{W}$ model dependant
Ingress Protection Rating	• IP67 (wired versions)

EMC

Emissions	• EN55022 class B conducted & radiated with external components - see application notes
ESD Immunity	• EN61000-4-2, level 2 Perf Criteria A
Radiated Immunity	• EN61000-4-3, level 2 Perf Criteria A
EFT/Burst	• EN61000-4-4, level 2 Perf Criteria A
Surge	• EN61000-4-5, level 2 Perf Criteria A
Conducted Immunity	• EN61000-4-6, level 2 Perf Criteria A

Models and Ratings

With Dimming Control

Output Power	Input Voltage Range	Output Voltage	Output Current	Efficiency	Model Number
8.0 W	7 - 30 V	2 - 28 V	300 mA	95%	LDU0830S300†^
8.0 W	7 - 30 V	2 - 28 V	350 mA	95%	LDU0830S350†^
14.0 W	7 - 30 V	2 - 28 V	500 mA	95%	LDU2430S500†^
17.0 W	7 - 30 V	2 - 28 V	600 mA	95%	LDU2430S600†^
20.0 W	7 - 30 V	2 - 28 V	700 mA	95%	LDU2430S700†^
24.0 W	7 - 30 V	2 - 28 V	1000 mA	95%	LDU2430S1000†^

Wired Versions (No Dimming Control)

Output Power	Input Voltage Range	Output Voltage	Output Current	Efficiency	Model Number
8.0 W	7 - 30 V	2 - 28 V	350 mA	95%	LDU0830S350-W
14.0 W	7 - 30 V	2 - 28 V	500 mA	95%	LDU2430S500-W
20.0 W	7 - 30 V	2 - 28 V	700 mA	95%	LDU2430S700-W
24.0 W	7 - 30 V	2 - 28 V	1000 mA	95%	LDU2430S1000-W

Wired Version with Dimming Control

Output Power	Input Voltage Range	Output Voltage	Output Current	Efficiency	Model Number
8.0 W	7 - 30 V	2 - 28 V	350 mA	95%	LDU0830S350-WD
14.0 W	7 - 30 V	2 - 28 V	500 mA	95%	LDU2430S500-WD
20.0 W	7 - 30 V	2 - 28 V	700 mA	95%	LDU2430S700-WD
24.0 W	7 - 30 V	2 - 28 V	1000 mA	95%	LDU2430S1000-WD

† Available from Farnell & element14. See pages 284-290.

^ Available from Newark. See pages 291-296.

Mechanical Details

LDU08: 14 Pin DIL

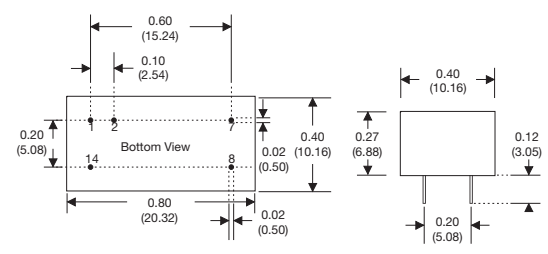

LDU08 - Wired Versions

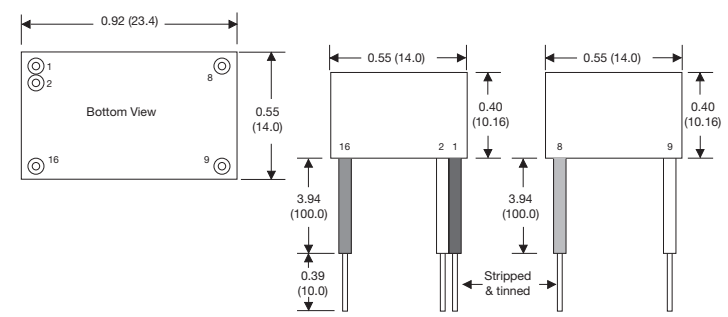

LDU24- 16 Pin DIL

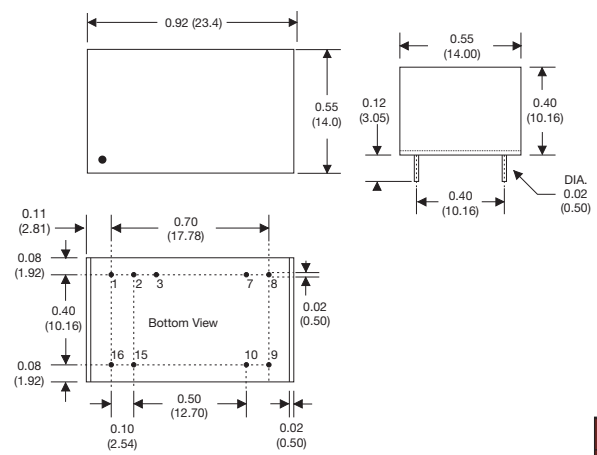

LDU24 - Wired Versions

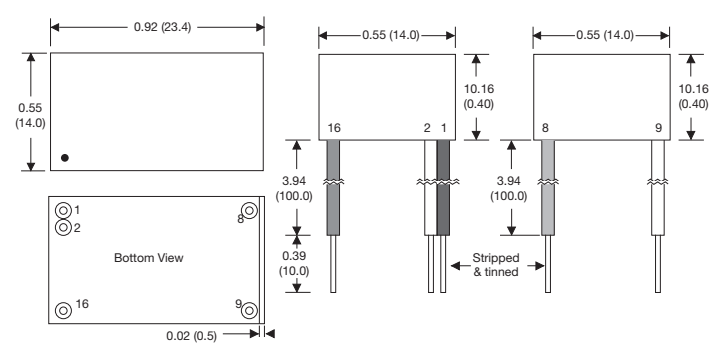

Notes

- All dimensions are in inches (mm)
- Weight: LDU08 - 0.006 lbs (2.6 g) approx.
LDU08 (wired version) - 0.02 lbs (11.1 g) approx.
LDU24 - 0.014 lbs (6.2 g) approx.
LDU24 (wired version) - 0.02 lbs (11.1 g) approx.
- Pin diameter: 0.02±0.002 (0.5±0.05)
- Pin pitch tolerance: ±0.014 (±0.35)
- Case tolerance: ±0.02 (±0.5)

LDU Connections						Function
LDU08	LDU08-W	LDU08-WD	LDU24	LDU24-W	LDU24-WD	
1	1 (Black)	1 (Black)	1 & 2	1 (Black)	1 (Black)	-Vin: -DC supply
2	No Wire	2 (White)	3	No Wire	2 (White)	Control
7	8 (Blue)	8 (Blue)	7 & 8	8 (Blue)	8 (Blue)	-Vout: LED cathode connection
8	9 (Yellow)	9 (Yellow)	9 & 10	9 (Yellow)	9 (Yellow)	+Vout: LED anode connection
14	16 (Red)	16 (Red)	15 & 16	16 (Red)	16 (Red)	+Vin: +DC supply

Note: LDU08: Do not connect Pin 1 (-Vin) to Pin 7 (-Vout).
LDU24: Do not connect Pins 1 & 2 (-Vin) to Pins 7 & 8 (-Vout).



Models and Ratings

With Dimming Control

Output Power	Input Voltage Range	Output Voltage	Output Current	Ripple & Noise (pk-pk)	Efficiency	Model Number
9.0 W	7 - 60 V	2 - 57 V	150 mA	150 mV	97%	LDU4860S150
14.0 W	7 - 60 V	2 - 57 V	250 mA	200 mV	97%	LDU4860S250
17.0 W	7 - 60 V	2 - 57 V	300 mA	250 mV	97%	LDU4860S300
20.0 W	7 - 60 V	2 - 57 V	350 mA	300 mV	97%	LDU4860S350
29.0 W	7 - 60 V	2 - 57 V	500 mA	400 mV	97%	LDU4860S500
34.0 W	7 - 60 V	2 - 57 V	600 mA	450 mV	97%	LDU4860S600
40.0 W	7 - 60 V	2 - 57 V	700 mA	500 mV	97%	LDU4860S700
48.0 W	7 - 60 V	2 - 48 V	1000 mA	800 mV	97%	LDU4860S1000

Wired Versions (No Dimming Control)

Output Power	Input Voltage Range	Output Voltage	Output Current	Ripple & Noise (pk-pk)	Efficiency	Model Number
9.0 W	7 - 60 V	2 - 57 V	150 mA	150 mV	97%	LDU4860S150-W
14.0 W	7 - 60 V	2 - 57 V	250 mA	200 mV	97%	LDU4860S250-W
17.0 W	7 - 60 V	2 - 57 V	300 mA	250 mV	97%	LDU4860S300-W
20.0 W	7 - 60 V	2 - 57 V	350 mA	300 mV	97%	LDU4860S350-W
29.0 W	7 - 60 V	2 - 57 V	500 mA	400 mV	97%	LDU4860S500-W
34.0 W	7 - 60 V	2 - 57 V	600 mA	450 mV	97%	LDU4860S600-W
40.0 W	7 - 60 V	2 - 57 V	700 mA	500 mV	97%	LDU4860S700-W
48.0 W	7 - 60 V	2 - 48 V	1000 mA	800 mV	97%	LDU4860S1000-W

Wired Version with Dimming Control

Output Power	Input Voltage Range	Output Voltage	Output Current	Ripple & Noise (pk-pk)	Efficiency	Model Number
9.0 W	7 - 60 V	2 - 57 V	150 mA	150 mV	97%	LDU4860S150-WD
14.0 W	7 - 60 V	2 - 57 V	250 mA	200 mV	97%	LDU4860S250-WD
17.0 W	7 - 60 V	2 - 57 V	300 mA	250 mV	97%	LDU4860S300-WD
20.0 W	7 - 60 V	2 - 57 V	350 mA	300 mV	97%	LDU4860S350-WD
29.0 W	7 - 60 V	2 - 57 V	500 mA	400 mV	97%	LDU4860S500-WD
34.0 W	7 - 60 V	2 - 57 V	600 mA	450 mV	97%	LDU4860S600-WD
40.0 W	7 - 60 V	2 - 57 V	700 mA	500 mV	97%	LDU4860S700-WD
48.0 W	7 - 60 V	2 - 48 V	1000 mA	800 mV	97%	LDU4860S1000-WD

Mechanical Details

LDU48 - 24 Pin DIL

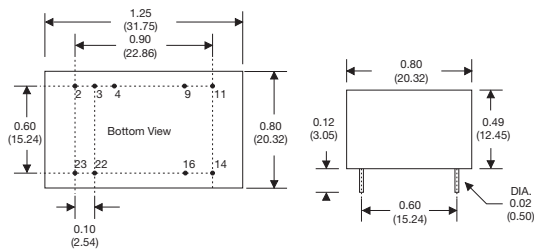

LDU48 - Wired Versions

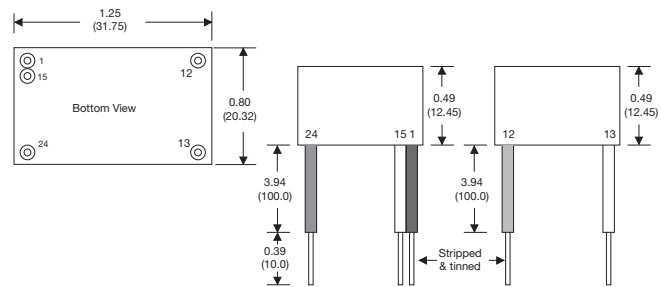

LDU48 Connections			
LDU48	LDU48-W	LDU48-WD	Function
2 & 3	1 (Black)	1 (Black)	-Vin: -DC supply
4	No Wire	15 (White)	Control
9 & 11	12 (Blue)	12 (Blue)	-Vout: LED cathode connection
14 & 16	13 (Yellow)	13 (Yellow)	+Vout: LED anode connection
22 & 23	24 (Red)	24 (Red)	+Vin: +DC supply

Notes

- All dimensions are in inches (mm)
- Weight: LDU48 - 0.04 lbs (17.7 g) approx.
LDU48 (wired version) - 0.04 lbs (18.0 g) approx.
- Pin diameter: 0.02±0.002 (0.5±0.05)
- Pin pitch tolerance: ±0.014 (±0.35)
- Case tolerance: ±0.02 (±0.5)

Note: Do not connect pins 1 & 2 (-Vin) to pins 9 & 11 (-Vout)

Derating Curve

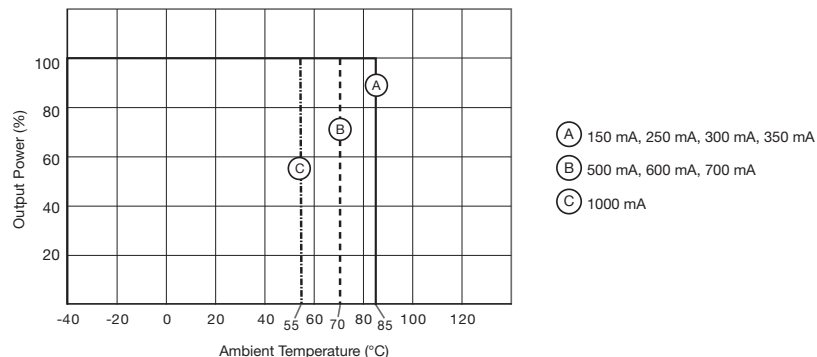

Output Current Adjustment by Variable Resistor

By connecting a variable resistor between control and GND, simple dimming can be achieved. Capacitor is optional for HF noise rejection. Recommended value is 0.22 μF.

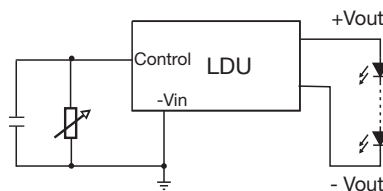

The output current can be determined using the equation:

$$I_{out} = \frac{I_{out} \times R}{(R + 200\text{ k})}$$

Where the value of R is between 0 and 2 MΩ, the maximum adjustment range of output current is 25% to 90% (For Vin-Vout, LDU08 & 24: <20 VDC, LDU48: <30 VDC)

Output Current Adjustment by DC Voltage

Control Voltage Range: 0.3 V to 1.25 VDC

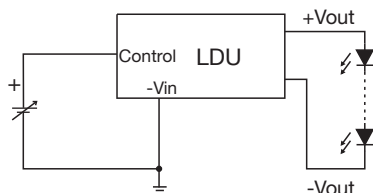

The output current is given by:

$$I_{out\ nom} = I_{out} \times \frac{Control}{1.25}$$

Output Current Adjustment by PWM

Directly driving control input

A Pulse Width Modulated (PWM) signal with duty cycle DPWM can be applied to the control pin, as shown:

$$I_{out\ nom} = I_{out} \times D_{pwm} \text{ (} D_{pwm} = \text{PWM duty cycle)}$$

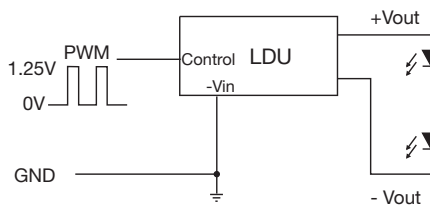

Input Filter to meet Class B Conducted Emissions

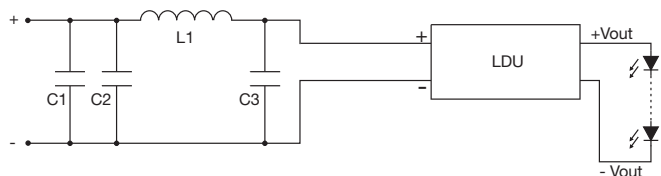

	LDU08	LDU24	LDU48
C1	10 μF	10 μF	4.7 μF
C2	Not Fitted	Not Fitted	4.7 μF
C3	47 μF	47 μF	Not Fitted
L1	68 μF	68 μF	47 μF