

RED & GREEN
Ruggedized Industrial
Laser Diode Modules



NEED A TOUGHER LASER?

BEA Electro Sales' Ruggedized Industrial Laser Diode Modules stand up to the most demanding conditions.

Ready for virtually unlimited heavy-duty applications, this unit is built to take extreme abuse in the toughest jobs.



- Applications:**
- | | |
|------------------------|--------------------|
| Metal-forming | Welding |
| Drilling | Alignment |
| Punch Presses | Targeting |
| Heavy Duty Saws | Positioning |

Light from green lasers is 7 times more visible to the human eye than red laser light!

If you have high ambient light conditions, green laser diode modules are the choice for you.

With a stainless steel case and brass mounting nut, the unit may be panel- or bracket-mounted and used in the heaviest equipment applications.

When paired with BEA Lasers Diffractive Optical Elements, our Ruggedized Industrial Laser Diode Modules will aid in targeting, alignment and positioning applications.

- Built to withstand:**
- Liquids (water resistant)
 - Vibration
 - Chemicals
 - Impact
 - Dust

Included:

The complete package includes the laser module, a connector cable assembly, and a DIN rail mounted power supply. Mounting brackets are also available as an option.

Pattern Designs Available:

- Standard:**
 Dot
Options:
 Crosshair, Target, Line

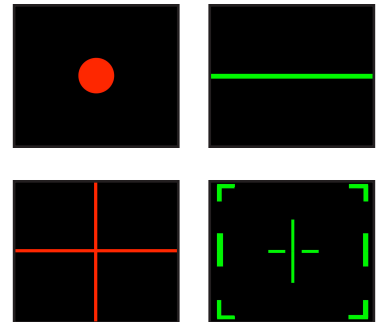

Ruggedized Industrial Laser Diode Modules are available in **Green (532nm)** or **Red (650nm)** colors.

BEA's Laser Diode Modules are factory-set to FDA-Approved Power Levels (<5mw, class IIIa) to comply with Section 21 DFR Part 1040.10-11.

BEA LASERS
 A Division of BEA Electro Sales

2330 Brickvale Drive
 Elk Grove Village, IL
 60007

PHONE: (847) 238-1420
 FAX: (847)-238-1423
 www.bea-eo.com

RED & GREEN Ruggedized Industrial Laser Diode Modules

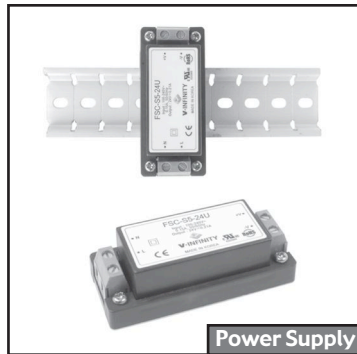
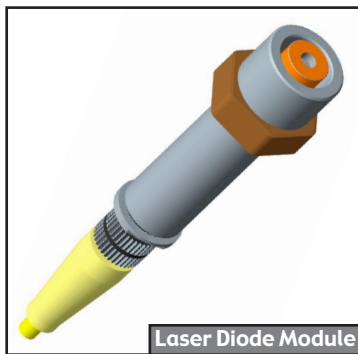
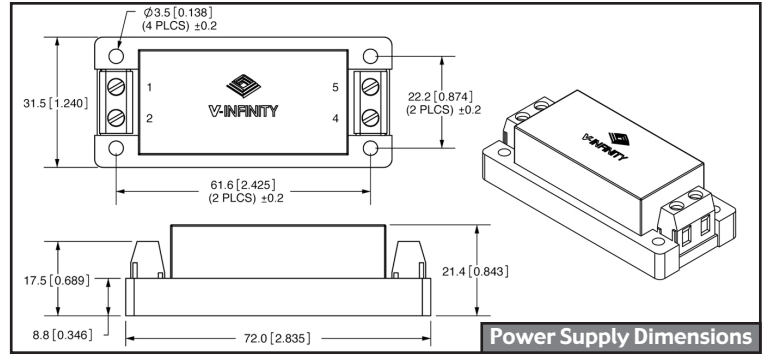
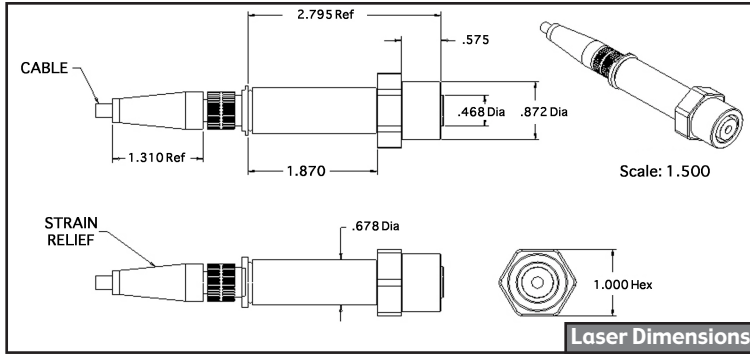

Model Numbers:
MIL 301RHD - RED LASER
MIL 302GHD - GREEN LASER

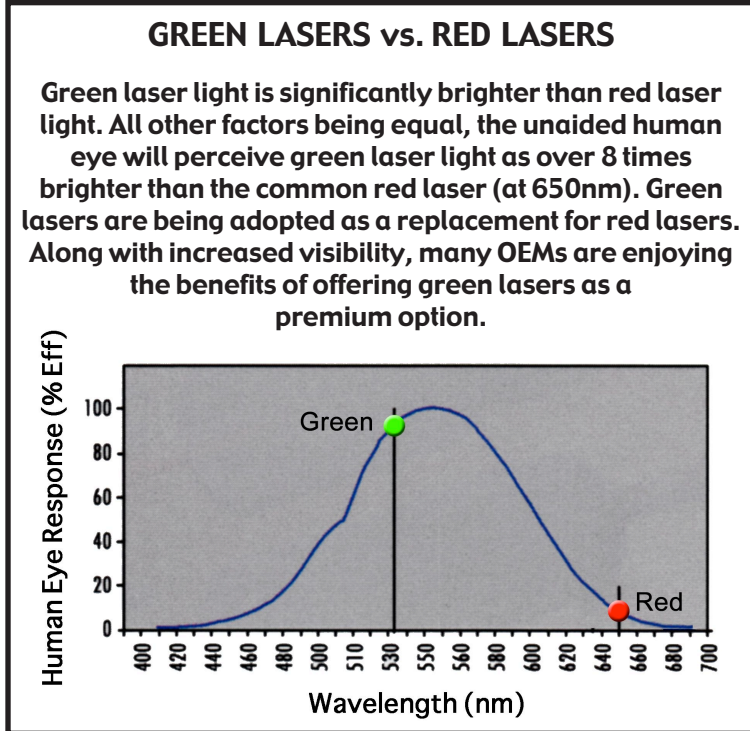

Optical		
Output Power (mW)	5	5
Wavelength (nm)	650 (Red Laser)	532 (Green Laser)
Class	IIIa	IIIa
Lens	Plastic	Glass
Focus	Fixed	Fixed
Operation Mode	Continuous Wave	Continuous Wave
Spectral Line width (nm)	<0.1	<0.1
Beam Diameter, 1/e ² (mm)	<1	<1.5
Beam Divergence (mrad)	0.8	<1.4
Output Power Stability for 1 hour	<±5% (typical 1%)	<±5% (typical 1%)

Electrical/Mechanical		
Operating Voltage (VDC)	3.3VDC	
Operating Current (mA)	<30	<300
Circuit Design	Auto Power Control	Auto Power Control
Lead Length	12'	
Housing Material	Stainless Steel	
Length	2.795 in.	
Body Diameter	.678 in.	
MTTF (hrs)*	>5,000	

DIN Rail Power Supply: FSC-S5	
Rated Input Voltage	85Vac-264Vac
Power	4.1W
RoHS	Yes
Humidity	20%~90% RH
Number of Outputs	1
UL/cUL	Approved to UL60950, CSA C22.2 NO. 60950

WARNING: Laser Beams and Hazards

Lasers produce an intense, highly directional beam of light. If directed, reflected or focused upon an object, laser light will be partially absorbed, raising the temperature of the surface and/or the interior of the object, potentially causing an alteration or deformation of the material. Lasers can also cause tissue damage. However, lower-power lasers may emit levels of laser light that are not a hazard.