

# Cameo Laser Series

## Features

### 1250 Series (Standard)

- Simple thread mounted industrial laser module
- Compact length for restricted areas
- User focusable
- Reliable connector construction
- Isolated metal case
- Designed for continuous cool running
- Simple to mount
- Wide range of focus distances

### 1260 Series(Gating)

- Offers the following additional features
- Third wire input facilitates rapid switching/gating
- Switching speeds up to 100kHz
- Operates directly from binary logic signals
- Effective in wide variety of light conditions
- Controlled chopping minimises power consumption and extends life
- Low speed enable input



The 1250 Cameo is a unique, versatile, high quality industrial laser module widely used in alignment applications. The 1260 Gated Cameo provides a switchable control input to turn the laser beam ON/OFF at high speed. A lower speed enable input is also provided.

Many applications require a chopped light source or need digital information to be encoded on the beam.

Using an appropriate detector, the laser light can be distinguished from other light sources, which might affect the alignment system.

The gated beam can also be detected at very low levels, making long range operation possible.

The isolated threaded mount houses an industrial grade laser diode, adjustable collimating lens and protected connectorised drive electronics.



## LENS OPTIONS

The Cameo series has four lens options,

C2 Lens	2 mm aperture lens
HG Lens	High quality aspheric lens
S Lens	Standard collimating lens
L8 Lens	8° short line lens

	C2 Lens	S Lens
Beam Size at aperture	2 mm	3 by 1 mm
beam size at nearest focus	50 $\mu\text{m}$	20 by 60 $\mu\text{m}$
beam divergence	0.2 mrad	0.5 by 0.2

**MECHANICAL SPECIFICATIONS**

Dimensions (L x W x H)	24 x 14 x 14	
Housing	Brass M12 thread front and black plastic back.	
Isolated Body	Yes	
Input Leads	1250 version	2, Red (+ve) Black (0V)
	1260 version	4, Red (+ve) Black (0V), Yellow (control), Blue (enable)
Lead length	300mm	

**OPTICAL SPECIFICATIONS**

Diode Power	1 mW to 3 mW
Wavelength	635 nm to 780 nm *
Power Stability	0.15 % / °C
Wavelength vs Temp	0.25nm / °C
Bore sighting	< 3mrad
Focus Range	30mm to infinity *
Astigmatism	30 µm
Beam Alignment	5 mrad
Pointing Stability	10 µrad

**ENVIRONMENTAL SPECIFICATIONS**

Operating Tempertaure	-10°C to +40°C
Storage temp	-25°C to +85°C
Operating Humidity (%RH)	90
MTTF at 25°C	25,000 hours

**DYNAMIC OUPUT**

Control input rise / fall time	5 µs
Enable input delay time	2 ms

**ELECTRICAL SPECIFICATIONS**

Input voltage (+ve) Red	3.0 Vdc to 6 Vdc	
Input voltage (-ve) Black	0 V	
Control Lead Yellow (1260 only)	off < 50 mV on > 2.0V	
Enable Lead Blue (1260 only)	off < 0.4 V on > 2.0 V	
Connector type	1250 version	JST 2 pin
	1260 version	JST 4 pin
Reverse - Polarity protection	Yes	
Operating Current	35 to 45 mA	

*Specifications are typical at 25°C unless otherwise stated*

**STANDARD WAVELENGTHS AND POWER OPTIONS**

635nm	1, 3 mW
650nm	1, 3 mW
670nm	1, 3 mW
780nm	1,3 mW
Custom	Please call for further details

*Please note wavelength tolerance can vary typically by ± 10nm.*

**MOUNTING**

The M12 x 1 threaded body provides a stable and convenient mounting method which also provides effective cooling of the laser diode to maximise the operating life. The metal body should be in good thermal contact with the mount, which should not be allowed to exceed the maximum case temperature.

**GATED CAMEO APPLICATION GUIDE****Introduction**

A common requirement for applications which use photodetectors, cameras and other non-visual sensing is the ability to rapidly switch the laser output ON and OFF. Simply applying and removing the supply voltage is rarely satisfactory and in certain cases can result in the destruction of the module. This is because laser diodes are very sensitive to spikes and surges, which are often the result of uncontrolled supply switching. To overcome this limitation, the 1260 gated Cameo has two additional inputs that are provided to control the output of the laser module in a reliable and predictable way.

**Input Description**

Some applications require a simple, slow speed ON/OFF switching. The 1260 series eliminates the requirement to provide an external switching device by providing a logic compatible enable input, capable of operating from low power logic and micro-processors. In this OFF condition, the module draws virtually no current and no light is emitted.

In applications which require higher speed switching, a second input is provided which directly controls the laser output. This input may be used in either of two ways, digital and analog control.

**Digital Control**

A logic LOW level turns the output completely OFF. However, applying a HIGH turns the laser ON after a control input delay. The output rise time after this delay is then much faster. This sets the maximum rate at which the module can switch fully ON and OFF.

**Analog Control**

This is the fastest way to control the laser output. With analog control, the output power can be changed from the maximum rated power to a low level, typically 1-2% of the maximum. By preventing the laser output turning OFF completely, there are no delays and the frequency response is maximised

**Modulation & Synchronization**

Using the yellow control lead the gate cameo laser may be modulated or synchronised by using an external signal. Required voltage range is 0 to +1 Vdc (to set the maximum intensity), frequency range is DC to 100 KHz.

## LASER SAFETY

Our lasers are compliant to IEC 60825-1 standards. The lasers fall within one of the following classifications depending on power, wavelength and fan angle. The labels supplied with the units are shown below.

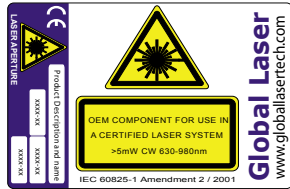

OEM Laser Label

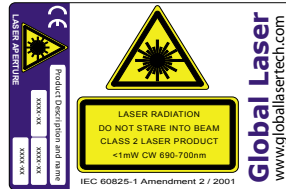

Class 2 Laser Label

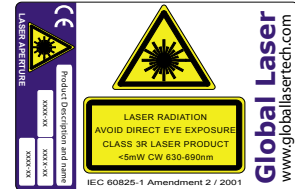

Class 3R Laser Label

## QUALITY & WARRANTY

The Cameo is supplied with a 12 month parts and labour warranty. Our manufacturing operations are certified to ISO9001.



## DIMENSIONS

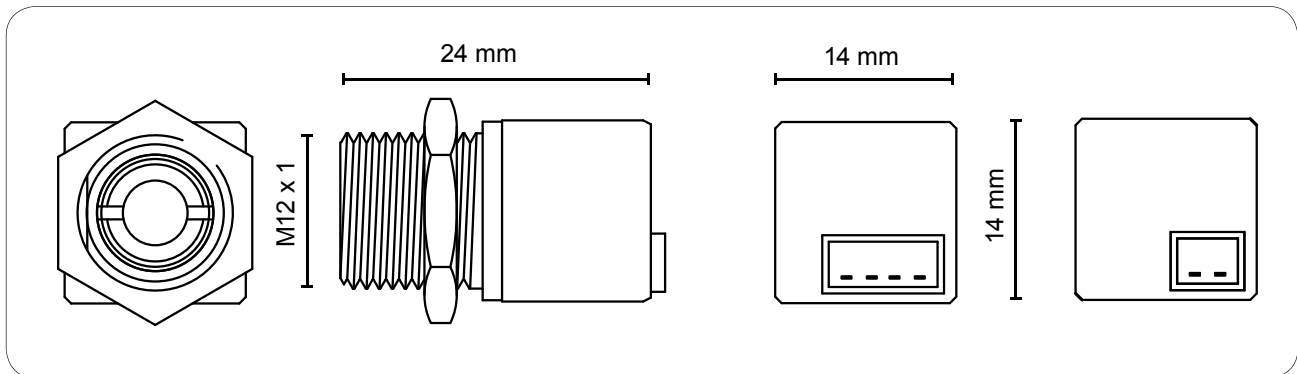

Please note: Global Laser reserve the right to change descriptions and specifications without notice



Cwmtillery Industrial Estate  
Abertillery. Gwent. UK. NP13 1LZ

T: +44 (0)1495 212213  
F: +44 (0)1495 322322  
E: [sales@globallasertech.com](mailto:sales@globallasertech.com)  
[www.globallasertech.com](http://www.globallasertech.com)

For further information about the cameo you can contact your local distributor or you can contact Global Laser in the UK.

Your Local Distributor Is: