

UNCONTROLLED DOCUMENT

PART NUMBER		REV.
SSP-13MDB152UP12G		B
REV.	E.C.N. NUMBER AND REVISION COMMENTS	DATE
A	E.C.N. #10950.	1.28.03
B	E.C.N. #10993.	5.21.03

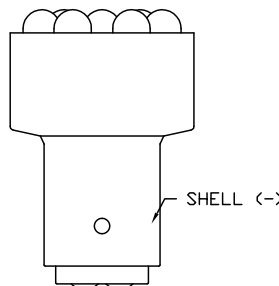
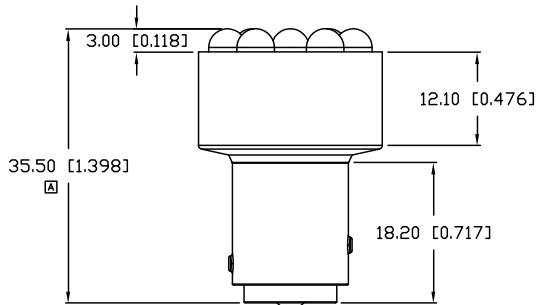
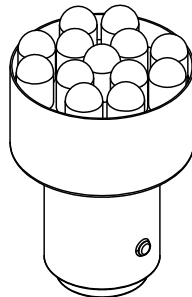
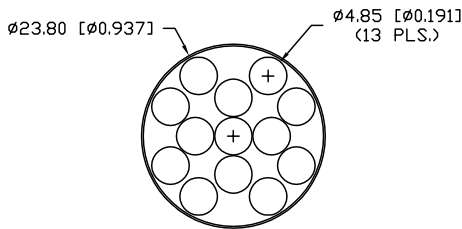

TAIL LIGHT (+) BRAKE LIGHT (+)

☐ ELECTRO-OPTICAL CHARACTERISTICS $T_A=25^{\circ}\text{C}$ $V_f=12\text{V}$

PARAMETER	MIN	TYP	MAX	UNITS	TEST COND
PEAK WAVELENGTH		525		nm	
FORWARD VOLTAGE		12.0		V_f	
REVERSE VOLTAGE	5.0			V_r	$I_f=100\mu\text{A}$
AXIAL INTENSITY		99100		mcd	$V_f=12\text{V}$
VIEWING ANGLE		30		2x theta	
EMITTED COLOR:	GREEN				
EPOXY LENS FINISH:	WATER CLEAR				

LIMITS OF SAFE OPERATION AT 25°C PER CHIP

PARAMETER	MAX	UNITS
PEAK FORWARD CURRENT*	100	mA
STEADY CURRENT	25	mA
POWER DISSIPATION	25	mW
DERATE FROM 25°C	-1.2	mW/°C
OPERATING, STORAGE TEMP.	-40 TO +85	°C

* $t < 10\mu\text{s}$

UNCONTROLLED DOCUMENT

*UNLESS OTHERWISE SPECIFIED TOLERANCES PER DECIMAL PRECISION ARE: X=±1 (±0.039), XX=±0.5 (±0.020), XXX=±0.25 (±0.010), XXXX=±0.127 (±0.005). LEAD SIZE=±0.05 (±0.002), LEAD LENGTH=±0.75 (±0.030). MIN.=^{+0.00}DECIMAL PRECISION, MAX.=^{-0.00}DECIMAL PRECISION

REV.	PART NUMBER
B	SSP-13MDB152UP12G
0.94" CIRCULAR, 13 LAMP POLYLED, GREEN, 1157 BASE, DOUBLE CONTACT AUTO BAYONET.	

CONFIDENTIAL INFORMATION
 THE INFORMATION CONTAINED IN THIS DOCUMENT IS THE PROPERTY OF SUNBRITE LEDS. EXCEPT AS SPECIFICALLY AUTHORIZED IN WRITING BY SUNBRITE LEDS, THE HOLDER OF THIS DOCUMENT SHALL KEEP ALL INFORMATION CONTAINED HEREIN CONFIDENTIAL AND SHALL PROTECT SAME IN WHOLE OR IN PART FROM DISCLOSURE AND DISSEMINATION TO ALL THIRD PARTIES.

RELIABILITY NOTE
 OUR MANY YEARS OF EXPERIENCE DATA ACCUMULATION INDICATE THAT SOLDER HEAT IS A MAJOR CAUSE OF EARLY AND FUTURE FAILURE. PLEASE PAY ATTENTION TO YOUR SOLDERING PROCESS.



286 E. HELEN ROAD
 PALATINE, IL 60067-6976
 PHONE: +1.847.348.3116
 FAX: +1.847.359.2867
 WEB: www.sunbriteleds.com

DRAWN:	CHECKED:	APPROVED:	DATE:
CT			10.17.02
			PAGE: 1 OF 1