



SPC  
TECHNOLOGY

ALL RIGHTS RESERVED. NO PORTION OF THIS PUBLICATION,  
WHETHER IN WHOLE OR IN PART CAN BE REPRODUCED  
WITHOUT THE EXPRESS WRITTEN CONSENT OF SPC  
TECHNOLOGY.

SPC-F005.DWG

REVISIONS

DCP #	REV	DESCRIPTION	DRAWN	DATE	CHECKD	DATE	APPRVD	DATE
			VEE	02-08-10	JAG	03-08-10	XXX	16-08-10

DOC. NO. SPC-F005 \* Effective: 7/8/02 \* DCP No: 1398



Specifications:

1. Volts: 7.5
2. Amps: 0.22
3. Watts: 1.65
4. MSCP: 1
5. Filament: C-2R
6. Life: 1000 hours

Part Number Table

Description	Part Number
G 3 - 1/2 Miniature Screw Base Lamp	50

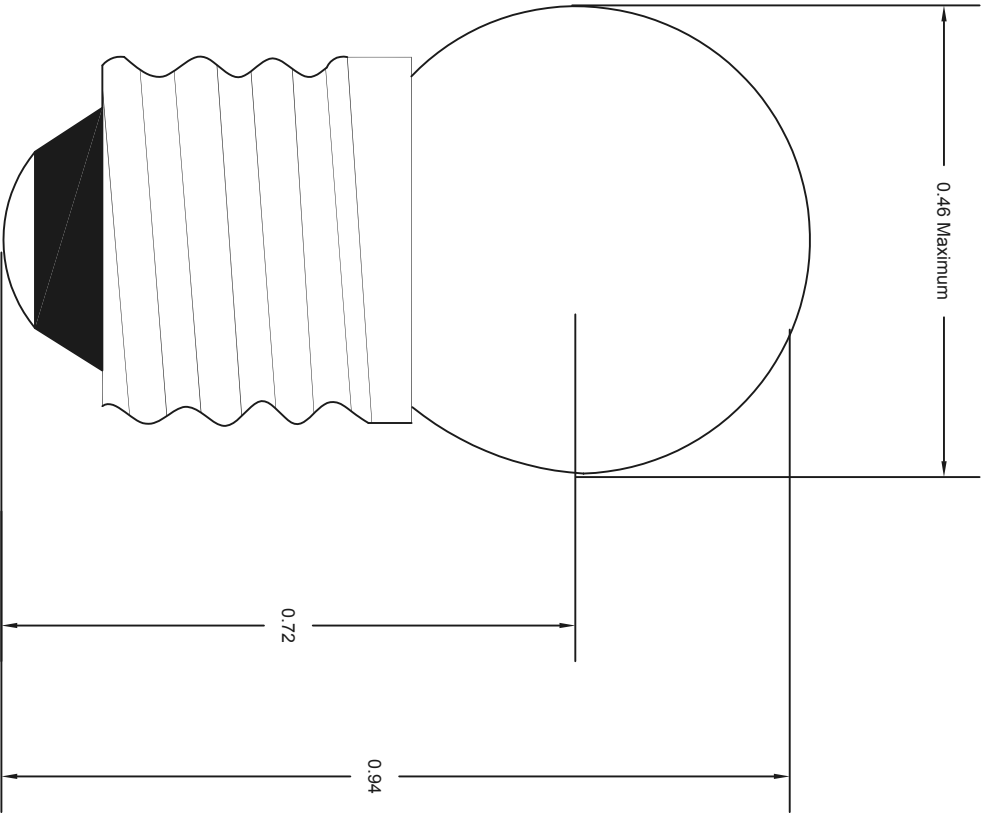

Dimensions : Inches (mm)

TOLERANCES:

UNLESS OTHERWISE SPECIFIED, DIMENSIONS ARE FOR REFERENCE PURPOSES ONLY.

DISCLAIMER:  
ALL STATEMENTS AND TECHNICAL INFORMATION CONTAINED  
HEREIN ARE BASED UPON INFORMATION AND/OR TESTS WE  
BELIEVE TO BE ACCURATE AND RELIABLE. SINCE THE  
CONDITIONS OF USE ARE BEYOND OUR CONTROL, THE  
USER SHALL DETERMINE THE SUITABILITY OF THE PRODUCT  
FOR THE INTENDED USE AND ASSUME ALL RISK AND  
LIABILITY WHATSOEVER IN CONNECTION THEREWITH.

DRAWN BY:

VEE

DATE:

02-08-10

DRAWING TITLE:

G 3 - 1/2 Miniature Screw Base Lamp

CHECKED BY:

JAG

DATE:

03-08-10

SIZE

XXX

DWG. NO.

XXX

XXX

ELECTRONIC FILE

50N8063

REV

A

APPROVED BY:

XXX

DATE:

16-08-10

SCALE:

NTS

U.O.M.: INCHES [mm]

SHEET:

1 OF 1