

ALL RIGHTS RESERVED. NO PORTION OF THIS PUBLICATION, WHETHER IN WHOLE OR IN PART CAN BE REPRODUCED WITHOUT THE EXPRESS WRITTEN CONSENT OF SPC TECHNOLOGY.

REVISIONS		DOC. NO.	SPC-F005	Effective:	12/21/88	Doc No.	880	
REP #	REV	DESCRIPTION	DRAWN	DATE	CHECKD	DATE	APPRVD	DATE
B		REVISED & REDRAWN					J.L.	1/7/93
948	C	CHG TO TABULAR SPEC. WAS IN 1**	HYO	5/1/00	JC	7/11/00	JC	7/11/00

SPC Type No.	Volts	AMPS	Watts	MSCP	Filament	Life (Hours)
161	14	0.19	2.66	1	C-2F	1500
168	14	0.35	4.9	3	C-2F	1500
193	14	0.33	4.62	2	C-2F	5000
194	14	0.27	3.78	2	C-2F	2500
* 259	6.3	0.25	1.575	0.65	C-2R	5000
464	28	0.17	4.76	3	C-2F	1500
* 555	6.3	0.25	1.575	0.9	C-2R	3000
656	28	0.06	1.68	0.62	C-2F	2500
657	28	0.08	2.24	0.62	C-2F	7500
658	14	0.08	1.12	0.31	C-2F	15000

\* NOTE: LCL IS 0.65

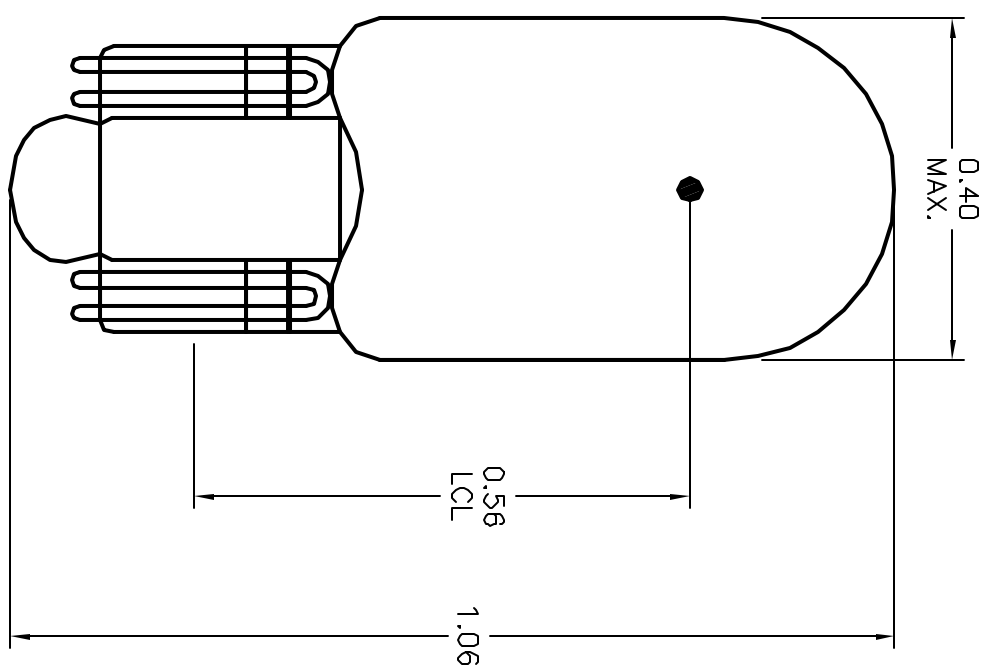

**DISCLAIMER**  
 ALL STATEMENTS AND TECHNICAL INFORMATION CONTAINED HEREIN ARE BASED UPON INFORMATION AND/OR TESTS WE BELIEVE TO BE ACCURATE AND RELIABLE. SINCE CONDITIONS OF USE ARE BEYOND OUR CONTROL, THE USER SHALL DETERMINE THE SUITABILITY OF THE PRODUCT FOR THE INTENDED USE AND ASSUME ALL RISK AND LIABILITY WHEREVER IN CONNECTION THERETHIN.

UNLESS OTHERWISE SPECIFIED, DIMENSIONS ARE FOR REFERENCE PURPOSES ONLY.

DRAWN BY:	J.C.	DATE:	1/6/93
CHECKED BY:	J.P.	DATE:	2/2/93
APPROVED BY:	J.L.	DATE:	2/8/93

**SPC TECHNOLOGY**

DRAWING TITLE: T- 3 1/4 WEDGE BASE LAMP

SIZE	DWG. NO.	ELECTRONIC FILE	REV
A	TA-257	TA-257.DWG	C
SCALE:	NTS	U.O.M.: INCHES	SHEET: 1 OF 1