

ALL RIGHTS RESERVED. NO PORTION OF THIS PUBLICATION, WHETHER IN WHOLE OR IN PART CAN BE REPRODUCED WITHOUT THE EXPRESS WRITTEN CONSENT OF SPC TECHNOLOGY.

REVISIONS			DOC. NO. SPC-F004 * Effective: 12/21/98 * DCP No: 680						
DCP #	REV	DESCRIPTION	DRAWN	DATE	CHECKD	DATE	APPRVD	DATE	
94B	A	RELEASED	HYD	7/12/00	JC	10/18/00	DJC	10/18/00	

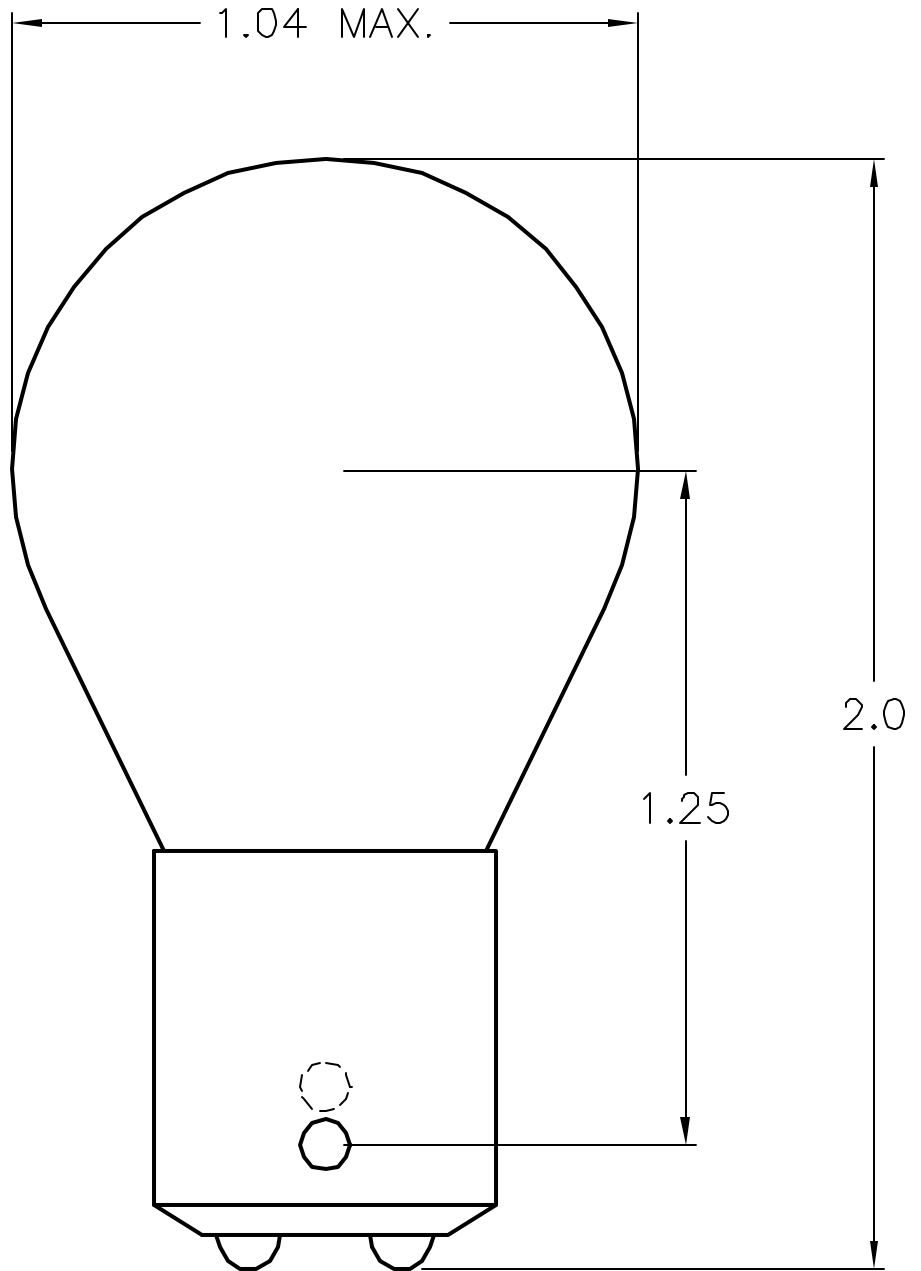

**SPECIFICATIONS:**

1. Volts: 12.8/14
2. AMPS: 2.1/0.59
3. Watts: 26.88/8.26
4. MSCP: 32/3
5. Filament: C-6/C-6
6. Life: 600/5000+

SPC-F004.DWG

**DISCLAIMER:**  
ALL STATEMENTS AND TECHNICAL INFORMATION CONTAINED HEREIN ARE BASED UPON INFORMATION AND/OR TESTS WE BELIEVE TO BE ACCURATE AND RELIABLE. SINCE CONDITIONS OF USE ARE BEYOND OUR CONTROL, THE USER SHALL DETERMINE THE SUITABILITY OF THE PRODUCT FOR THE INTENDED USE AND ASSUME ALL RISK AND LIABILITY WHATSOEVER IN CONNECTION THEREWITH.



**SPC TECHNOLOGY**

UNLESS OTHERWISE SPECIFIED, DIMENSIONS ARE FOR REFERENCE PURPOSES ONLY.	DRAWN BY:	DATE:	DRAWING TITLE:			
	HISHAM ODISH	7/12/00	S-8 DOUBLE CONTACT INDEX BASE LAMP			
	CHECKED BY:	DATE:	SIZE	DWG. NO.	ELECTRONIC FILE	REV
	JOHN COLE	10/18/00	A	1157	96F7955.DWG	A
APPROVED BY:	DATE:	SCALE: NTS		U.O.M.: INCHES		SHEET: 1 OF 1
DANIEL CAREY	10/18/00					