

SEPS525

160 RGB x 128 Dots, 262K Colors PM-OLED Display Driver and Controller

1. Product Preview

- 262k colors OLED single chip display driver IC
- Data Interface
 - Parallel interface : 68/80series MPU(8/9/16/18-bit)
 - Serial interface : SPI 4-wire interface
 - RGB interface : 18/16/6-bit interface
- Driver Output
 - 160× RGB columns(480), 128 rows
- Display RAM Capacity
 - $160 \times 18(\text{RGB}) \times 128 = 368,640$ bits
- Various Instructions Set
 - Power save mode
 - Reduced current driving available
 - Window mode
 - Partial display : programmable panel display size
 - Vertical scroll & Horizontal panning
- OLED Column Drive
 - Driving current control : 8-bit, 0uA ~ 255uA by 1uA step control
 - Pre_charge current control : 8-bit, 0uA ~ 2040uA by 8uA step control
 - Pre_charge time control : programmable pre_charge time(0clock ~ 15clocks) based on internal oscillator clock
- OLED Row Drive
 - Current sink : Max 120mA
- Internal Oscillator Circuit
 - Internal / External clock selectable
 - Frame rate : 90 frames/sec(75.0 ~ 150.0 frames/sec adjustable)
- Supply Voltage
 - VDD : 2.4 ~ 3.3V
 - VDDH : 8.0 ~ 18.0V
 - VDDIO : 1.6 ~ 3.3V
- Package : Au Bumped
- Ordering information

SEPS525F0A	COF Package
------------	-------------

2. Block Diagram

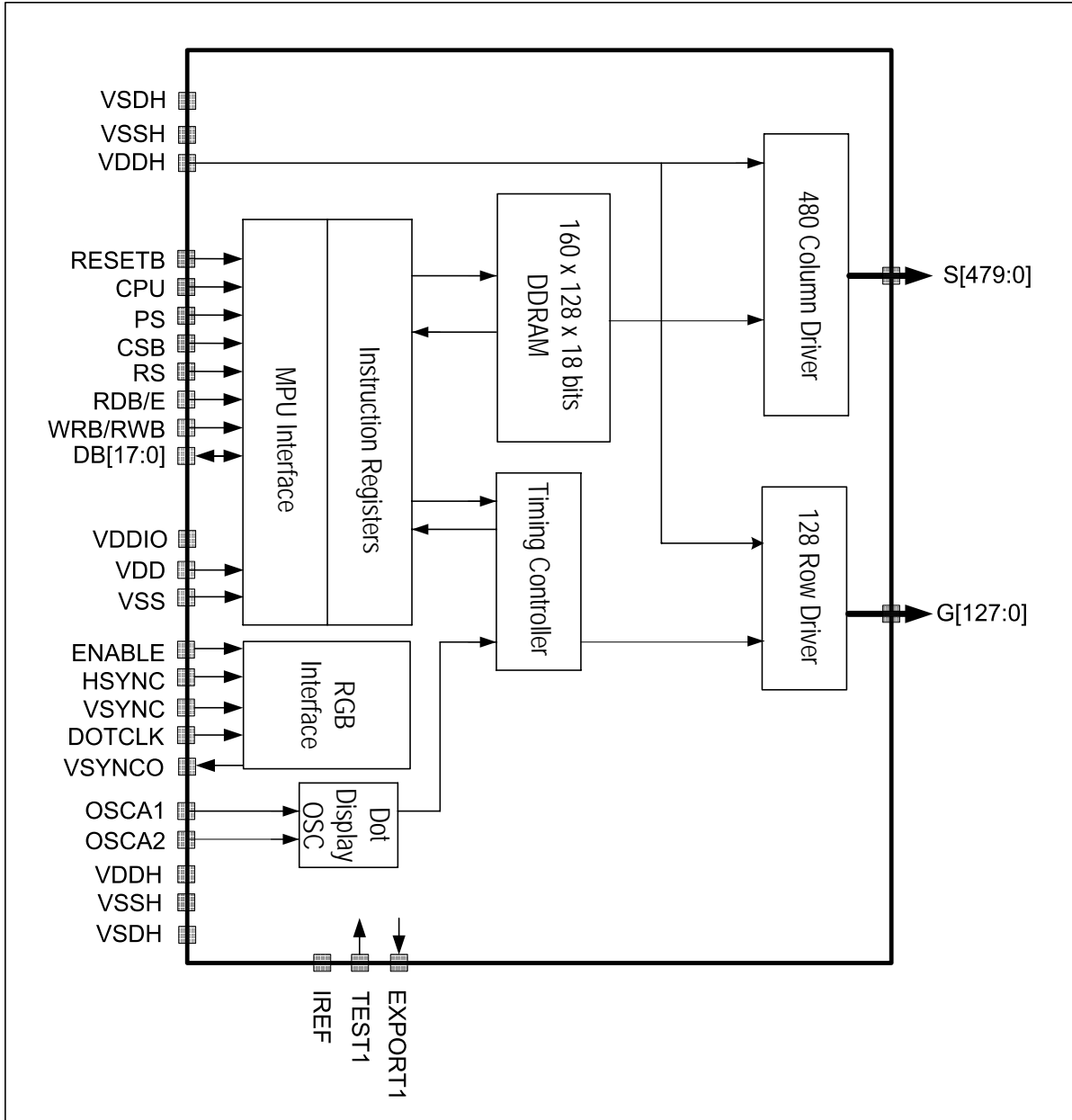

Block Diagram

3. Pin Description

Pin Name	Number Of Pins	I/O	Connected To	Description		
CPU	1	I	VSS or VDD	Selects the CPU type Low : 80-Series CPU, High : 68-Series CPU		
PS	1	I	VSS or VDD	Selects parallel/Serial interface type Low : serial, High : parallel		
CSB	1	I	MPU	Selects the SEPS525. Low : SEPS525 is selected and can be accessed High : SEPS525 is not selected and cannot be accessed		
RS	1	I	MPU	Selects the data / command Low : command, High : parameter / data		
RDB/E	1	I	MPU	For an 80-system bus interface, read strobe signal(active low) For an 68-system bus interface, bus enable strobe(active high) When using SPI, fix it to VDD or VSS level		
WRB/RWB	1	I	MPU	For an 80-system bus interface, write strobe signal(active low) For an 68-system bus interface, read/write select Low : Write, High : Read When using SPI, fix it to VDD or VSS level		
DB[17:0]	18	I/O	MPU	Serves as a 18_bit bi-directional data bus		
				<table border="1"> <thead> <tr> <th>PS</th> <th>Description</th> </tr> </thead> <tbody> <tr> <td>1</td> <td>8_bit bus : DB[17:10] 9_bit bus : DB[17:9] 16_bit bus : DB[17:10], DB[8:1] 18_bit bus : DB[17:0]</td> </tr> <tr> <td>0</td> <td>DB[17] SCL : Synchronous clock input DB[16] SDI : Serial data input DB[15] SDO : Serial data output</td> </tr> </tbody> </table>	PS	Description
PS	Description					
1	8_bit bus : DB[17:10] 9_bit bus : DB[17:9] 16_bit bus : DB[17:10], DB[8:1] 18_bit bus : DB[17:0]					
0	DB[17] SCL : Synchronous clock input DB[16] SDI : Serial data input DB[15] SDO : Serial data output					
Fix unused pins to the VSS level						
OSCA1	1	I	Oscillation-Resistor	Fine adjustment for oscillation		
OSCA2	1	O		Tie TBD k Ω ohms to OSCA1 between OSCA2 When the external clock mode is selected, OSCA1 is used external clock input		
RESETB	1	I	MPU	Reset SEPS525(active low)		
S[479:0]	480	O	PANEL	SEPS525 Display column outputs		
G[127:0]	128	O	PANEL	SEPS525 Display row outputs		
VDDH	2	-	POWER	Data, Scan Driver Power Supply(8V ~ 18V)		
VSSH	2	-	POWER	Scan Driver Ground		
VSDH	2	-	POWER	Data Driver Ground		
VDDIO	1	-	POWER	MPU I/F PAD Power Supply(1.6 ~ 3.3V)		
VDD	1	-	POWER	Logic power supply(2.4V ~ 3.3V)		
VSS	1	-	POWER	Logic ground.		
IREF	1	-	Resistor	Tie 70 k Ω to VSS		
TEST1	1	I	VSS or VDD	Selects the test mode		
EXPORT1	1	O	-	OSC Test		
VSYNCO	1	O	-	Vertical Sync. Output		
VSYNC	1	I	-	Vertical Sync. Input when RGB mode is selected		
HSYNC	1	I	-	Horizontal Sync. Input when RGB mode is selected		
DOTCLK	1	I	-	Dot clock Input when RGB mode is selected		
ENABLE	1	I	-	Video enable Input when RGB mode is selected		

4. Functional Description

MPU Interface

The SEPS525 has three high-speed system interface : a 68-system, an 80-system 8/9/16/18 bit bus, and a clock synchronous serial(SPI : Serial Peripheral Interface). Among the interface modes, a specific mode is selected by the setting of PS pin and MEMORY_WRITE_MODE register(16h).

The SEPS525 has 3-type registers : an index register(IR) 8-bits, a write data register(WDR), and a read data register(RDR). The IR stores index information for the control registers and the DDRAM. The WDR temporarily stores data to be written into control registers and the DDRAM, and the RDR temporarily stores data read from the DDRAM.

Data written into the DDRAM from the MPU is first written into the WDR and then it is automatically written into the DDRAM by internal operation. Data is read through the RDR when reading from the DDRAM, and the first read data is invalid and the second and the following data are valid.

Execution time for instruction excluding oscillation start is 0 clock cycle and instructions can be written in succession.

RS	80 mode		68 mode		Operation
	RDB	WRB	RWB	E	
0	0	1	1	1	Reads internal status
0	1	0	0	1	Writes indexes into IR
1	0	1	1	1	Reads from DDRAM through RDR
1	1	0	0	1	Writes into control registers and DDRAM through WDR

1) 18-bit Bus Interface(Index 16h)

DFM1	DFM0	TRI	Operation
0	0	x	18-bit bus operation

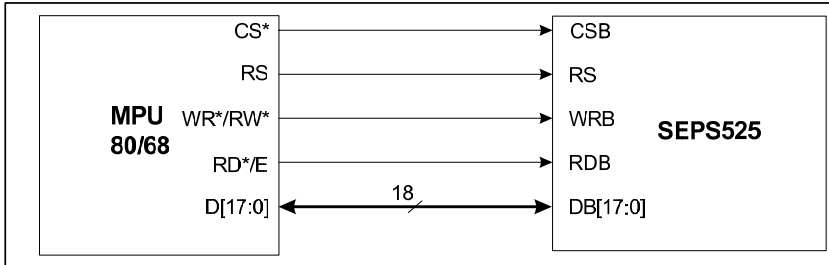

Index/Command Write

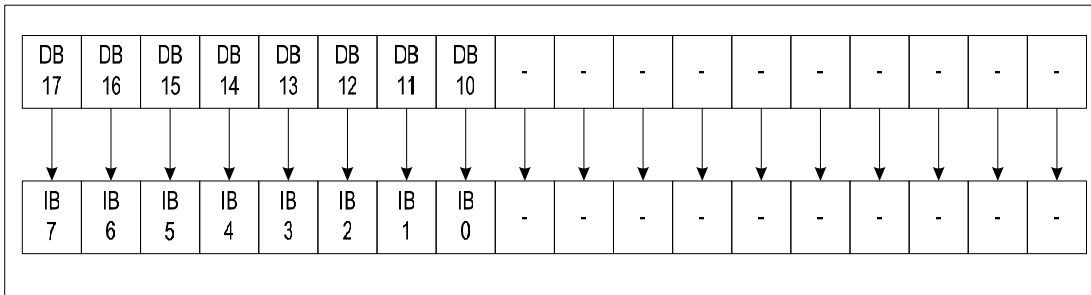

DDRAM Read/Write

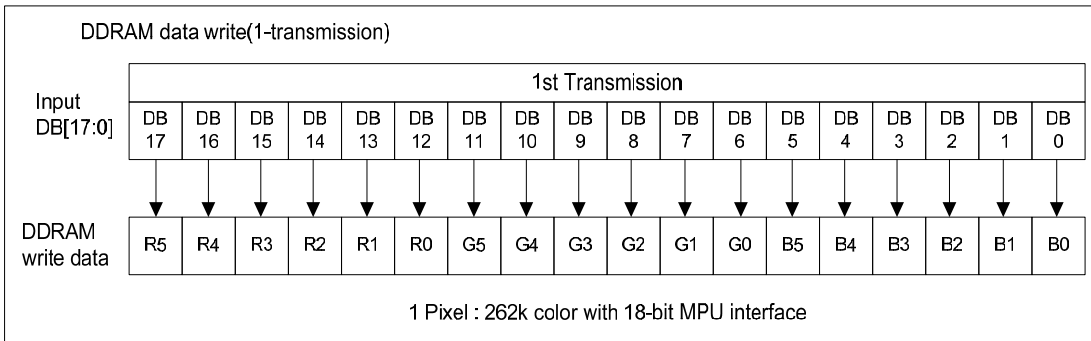

2) 16-bit Bus Interface

DFM1	DFM0	TRI	Operation
0	1	x	16-bit bus operation

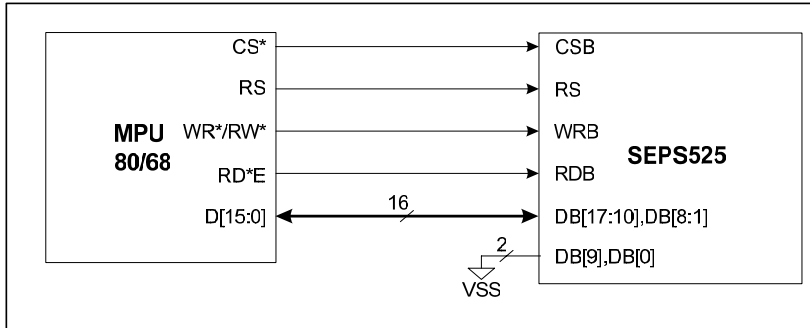

Index/Command Write

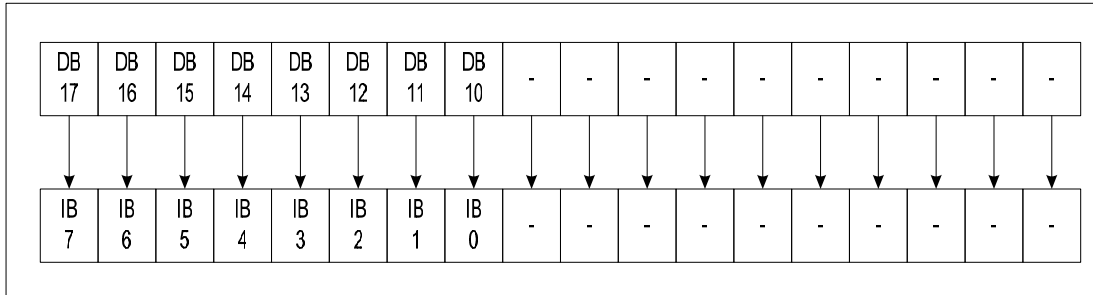

DDRAM Read/Write

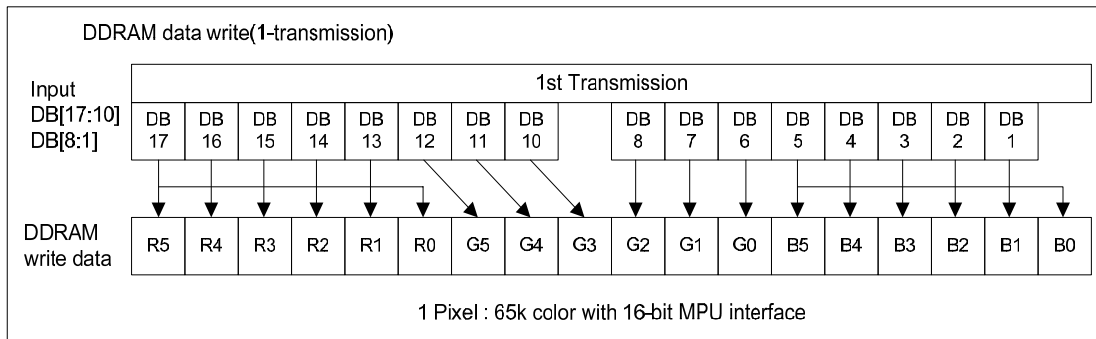

3) 9-bit Bus Interface

DFM1	DFM0	TRI	Operation
1	0	x	9-bit bus operation

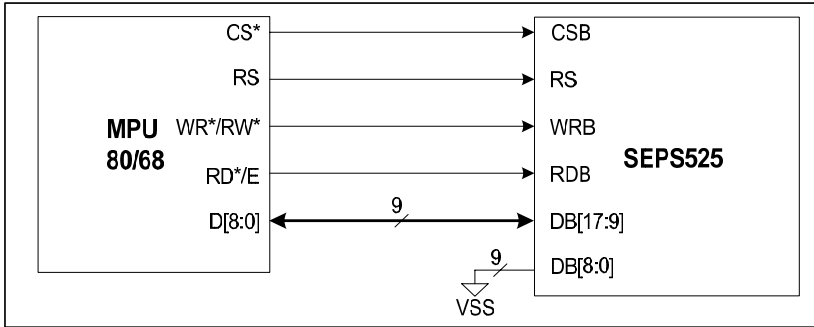

Index/Command Write

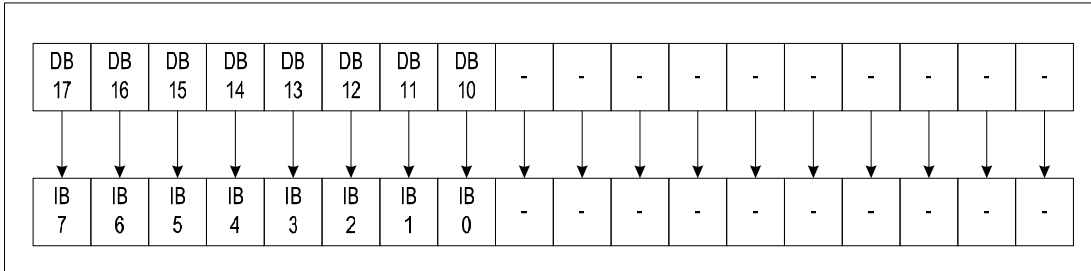

DDRAM Read/Write

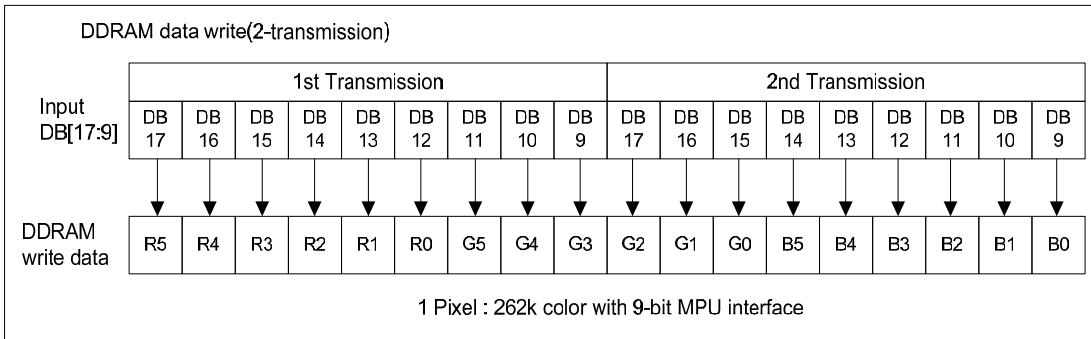

4) 8-bit Bus Interface

DFM1	DFM0	TRI	Operation
1	0	0	Dual 8-bit
1	1	1	Triple 6-bit

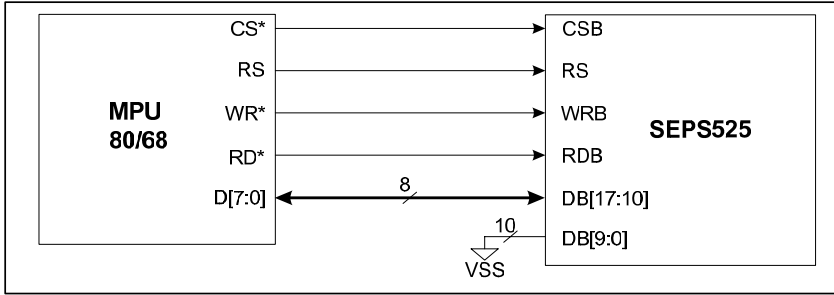

Index/Command Write

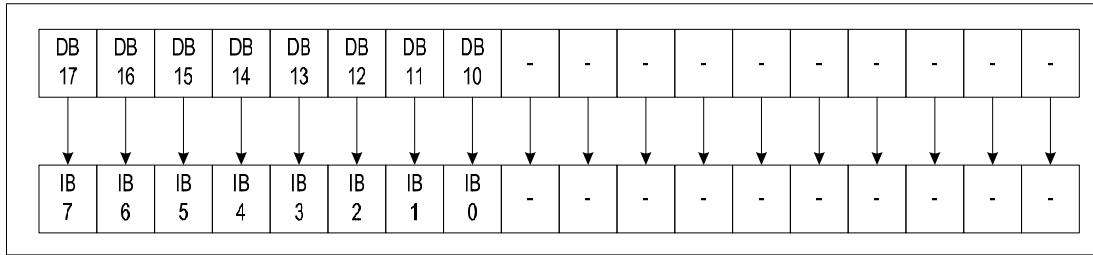

DDRAM Write/Read

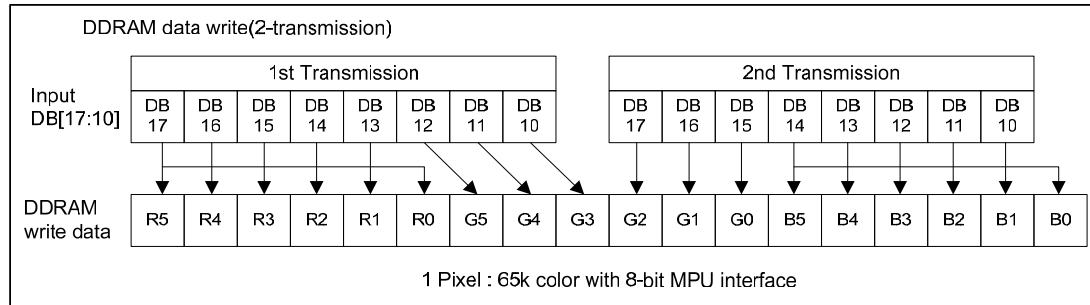

DDRAM Write/Read (TRI mode)

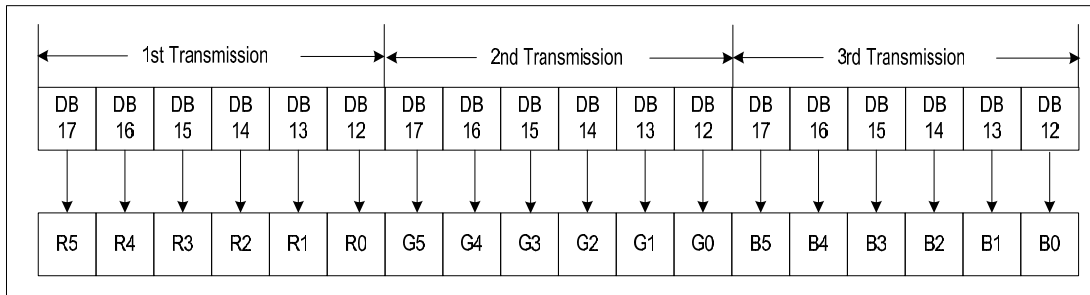

5) Clock Synchronized Serial Interface (SPI)

Setting PS pin to the “0” level allows clock synchronized serial data(SPI) transfer, using the chip select pin(CSB), RS pin, serial transfer clock pin(SCL) and serial data input(SDI).

When chip is not selected, internal shift register and counter is resets to initial value. Input data through SDI pin are latched at the rising edge of serial transfer clock(SCL). SDI inputs are converted to 16-bit or 18-bit data and transferred to memory at the 16th/18th rising edge serial clock, respectively.

Serial data input(SDI) is identified to display data or command by RS pin.

RS	Function
L	Command
H	Parameter/ Data

after 8-bit data transfer, serial transfer clock(SCL) goes to “H” at the non-access period. SDI and SCL signals are sensitive to external noise. To prevent miss operation chip selector state should be released(CSB = “H”) after 8-bit data transfer as shown in the following.

*Note : When the SPI mode is selected, DB[15] pin must be unconnected.

PS = “0”, DFM[1:0] = “11”, TRI = “0”

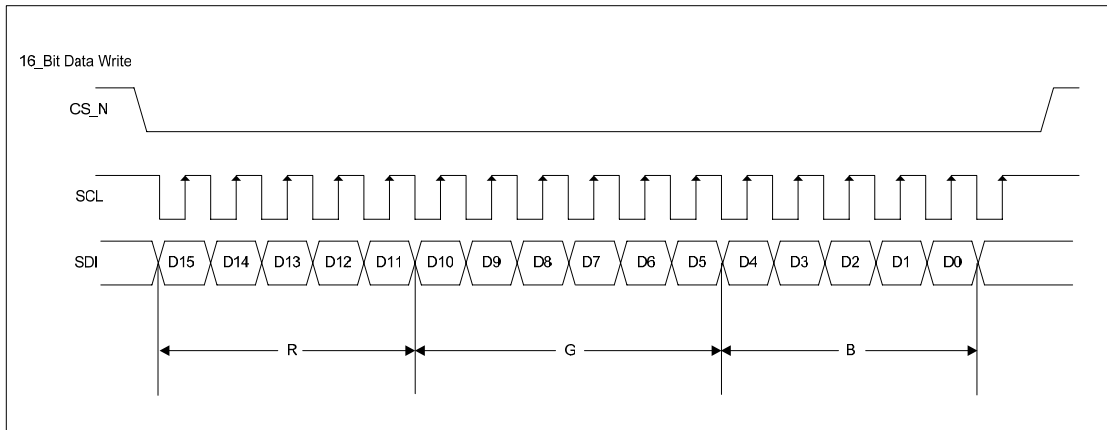

PS = “0”, DFM[1:0] = “11”, TRI = “1”

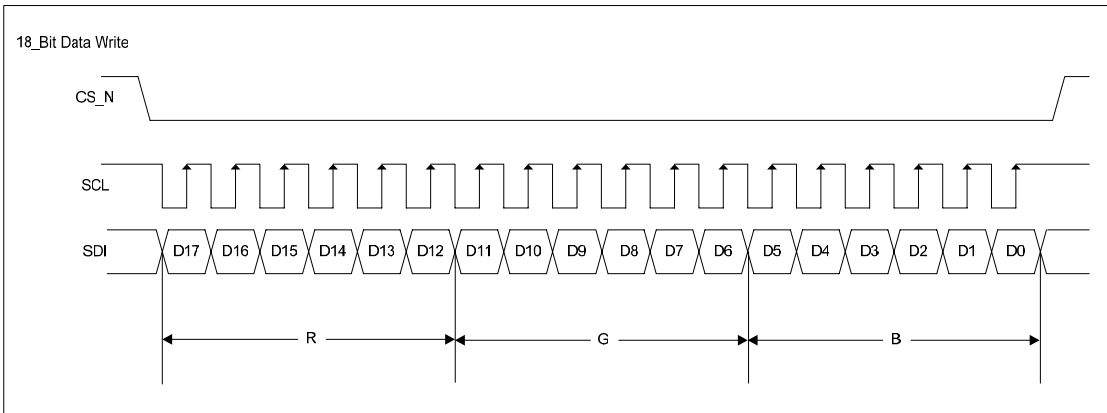

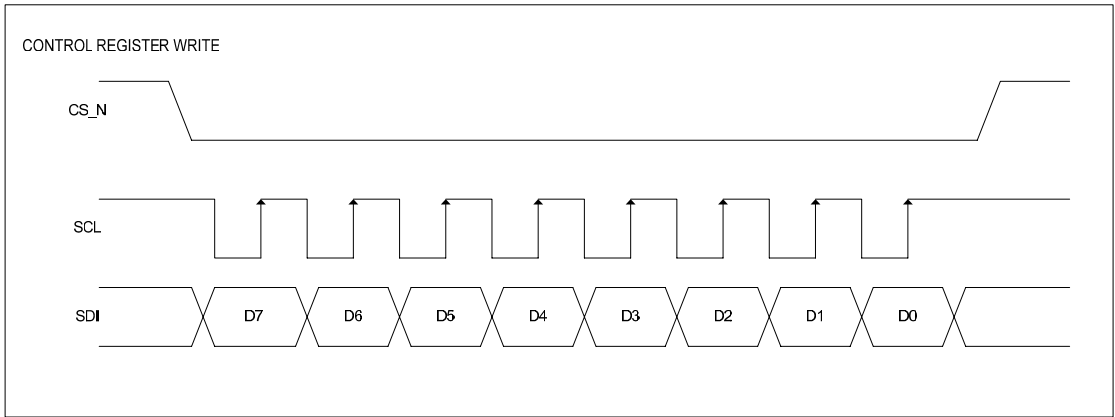
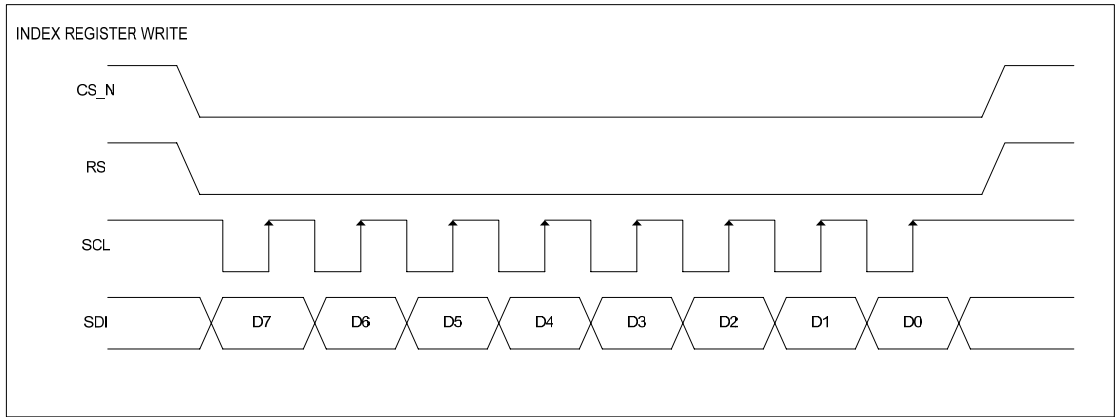

6) RGB Interface

When the RGB_IF register bit0 is set to "0", SEPS525 enters into the RGB interface mode and DDRAM write cycle is synchronized by DOTCLK.

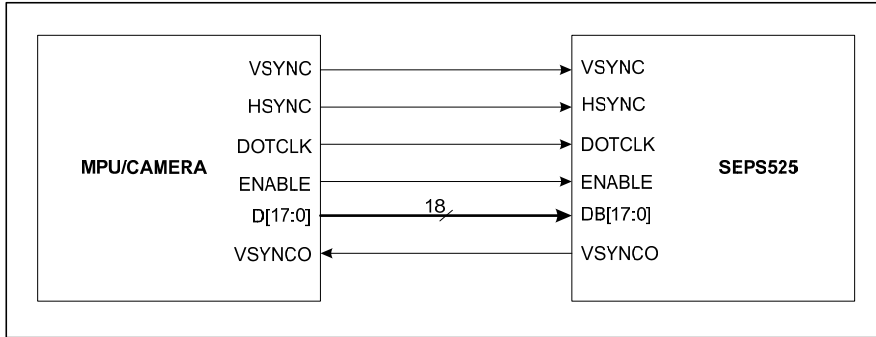

18-bit RGB interface

The 18-bit RGB interface is selected by setting RIM[1:0] bits to "00". DDRAM write operation is Synchronized with DOTCLK and ENABLE. Display data are transmitted to DDRAM in synchronization with 18-bit RGB data bus(DB[17:0]) and the data enable(ENABLE).

DDRAM Write

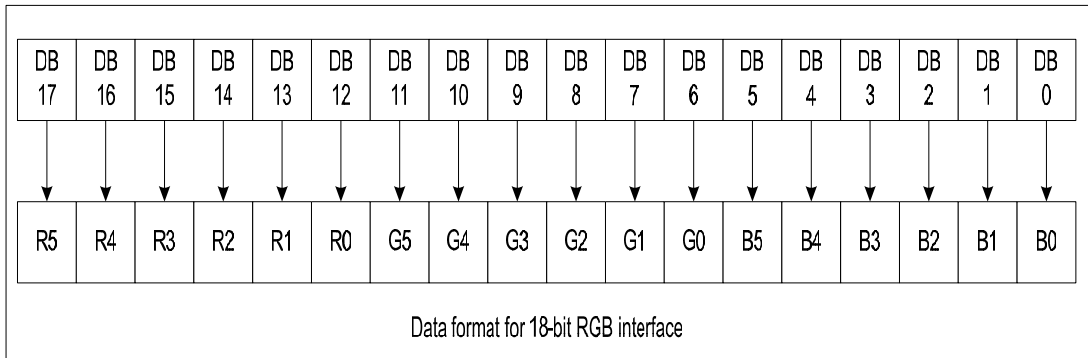

16-bit RGB interface

The 16-bit RGB interface is selected by setting RIM[1:0] bits to "01". DDRAM write operation is Synchronized with DOTCLK and ENABLE. Display data are transmitted to DDRAM in synchronization with 16-bit RGB data bus(DB[17:10], DB[8:1]) and the data enable(ENABLE).

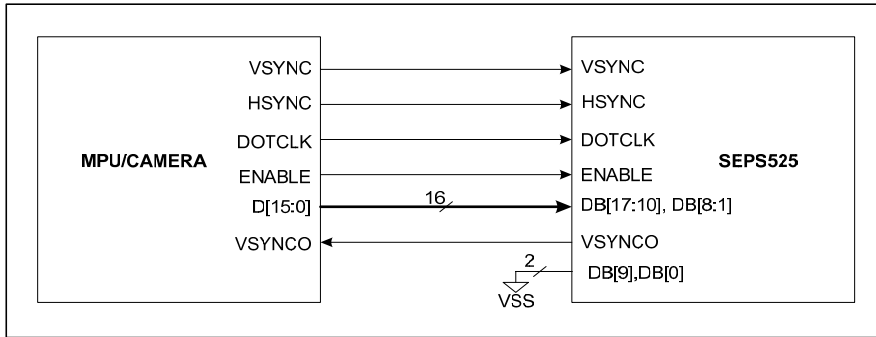

DDRAM Write

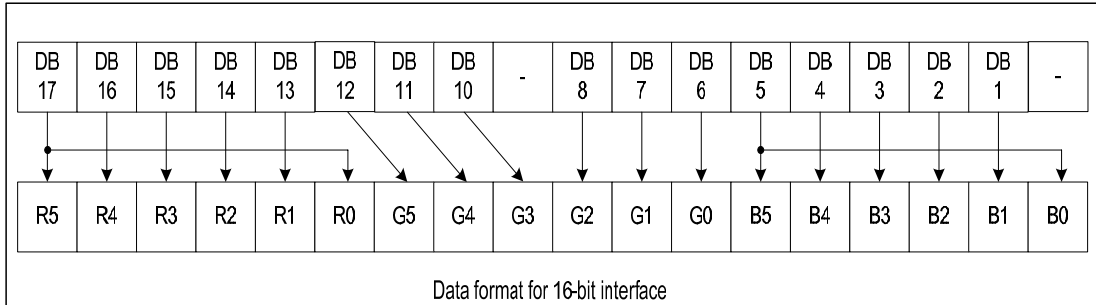

18/16-bit RGB interface timing

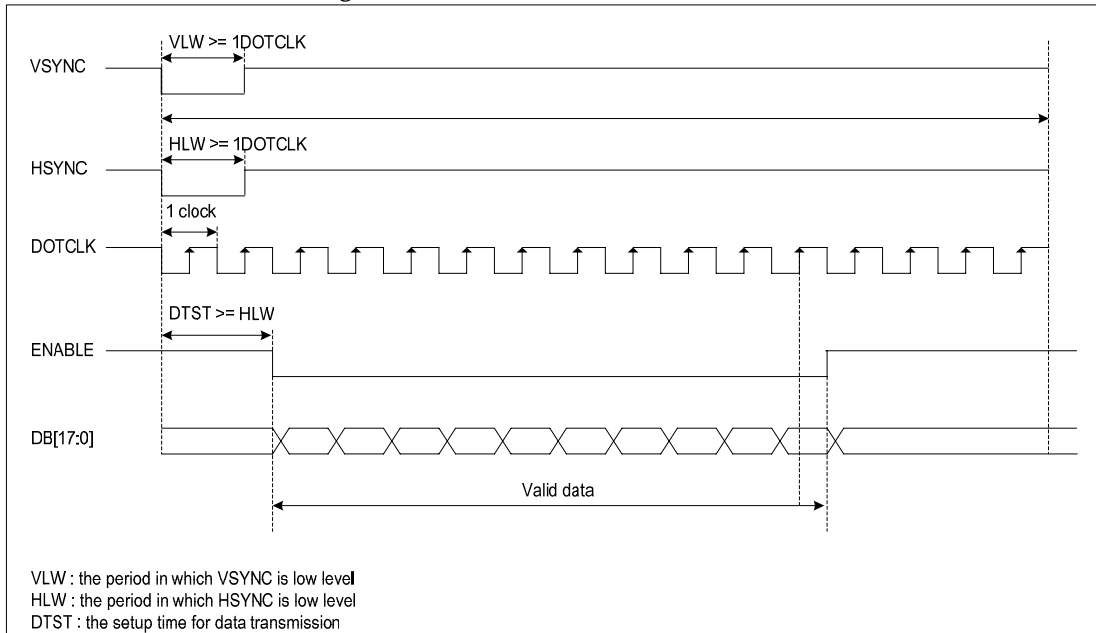

6-bit RGB interface

The 6-bit RGB interface is selected by setting RIM[1:0] bits to "10". DDRAM write operation is Synchronized with DOTCLK and ENABLE. Display data are transmitted to DDRAM in synchronization with 6-bit RGB data bus(DB[17:12]) and the data enable(ENABLE).

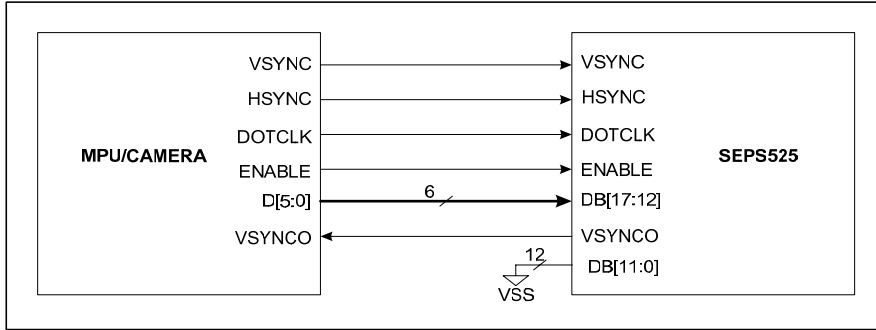

DDRAM Write

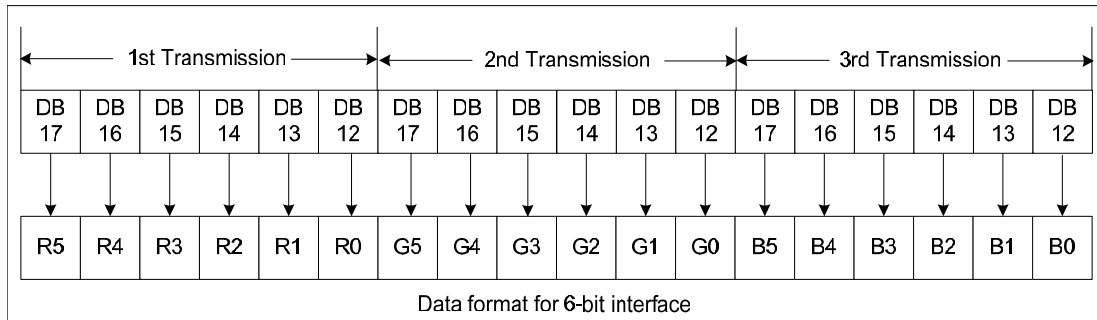

6-bit RGB interface timing

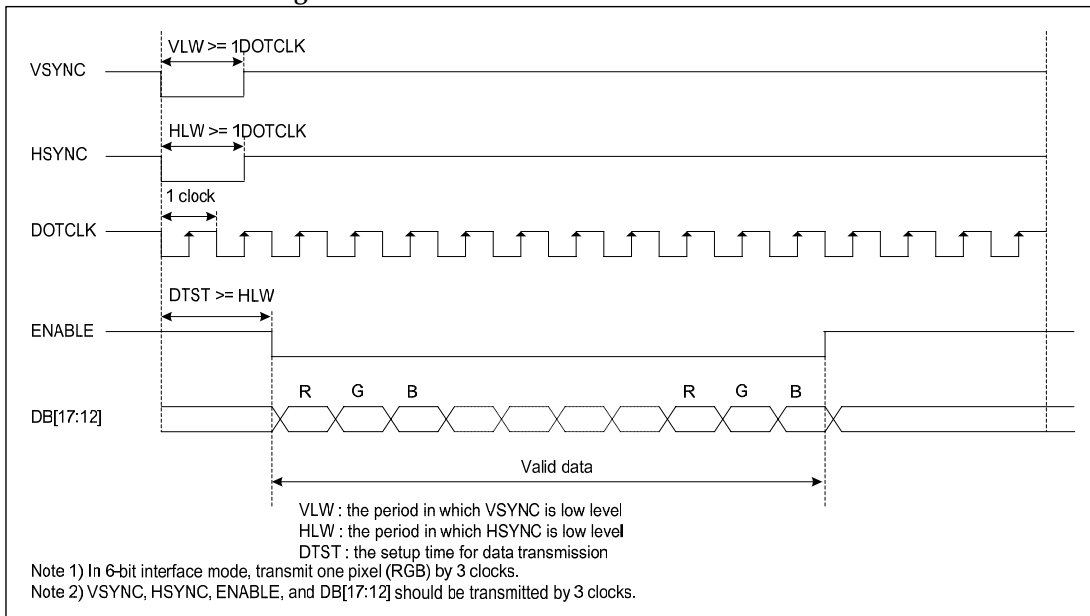

DDRAM(Display Data RAM) Addressing

The DDRAM stores pixel data for the display. It is composed of 128-row by 160-column x 18-bit addressable array. Address counter provides row and column address to DDRAM for access display pixel data from MPU.

Relationship Between DDRAM Address and Display Position

G0	G127	00h					-----				
G1	G126	01h									
G2	G125	02h									
G3	G124	03h									
G4	G123	04h									
G5	G122	05h									
.
.
.
.
G122	G5	79h									
G123	G4	7Ah									
G124	G3	7Bh									
G125	G2	7Ch									
G126	G1	7Eh									
G127	G0	7Fh									
RD=0	RD=1	Column Data	0	1	2	3	-----	156	157	158	159

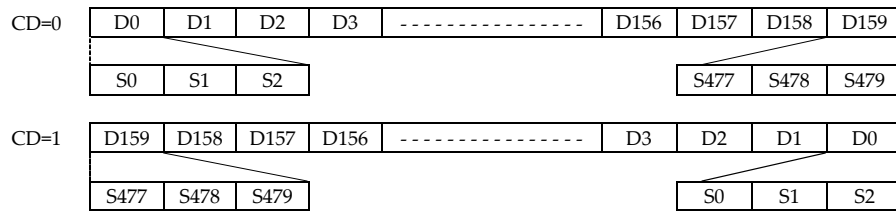

RD : Row scan shift direction register bit.
 CD : Column data shift direction register bit.

Window Address Function

When data is written to the on-chip DDRAM, a window address-range which is specified by the horizontal address register(start : MX1[7:0], end : MX2[7:0]) or the vertical address register(start : MY1[7:0], end : MY2[7:0]) can be written to consecutively. Data is written to addresses in the direction specified by the HC, VC(increment/decrement), and HV bit(H or V direction). When the image data is being written, data can be written consecutively without thinking of a data wrap by doing this.

The window must be specified within the DDRAM address area described below, Addresses must be set within the window address.

[Restriction on window address-range setting]

(horizontal direction) $00h \leq MX1[7:0] < MX2[7:0] \leq 9Fh$

(vertical direction) $00h \leq MY1[7:0] < MY2[7:0] \leq 7Fh$

Window address-range specification.

MX1[7:0] = 10h, MY1[7:0] = 2Fh

MY1[7:0] = 20h, MY2[7:0] = 3Fh

HC, VC = 1,1 (increment)

HV = 0 (horizontal writing)

Example of Address Operation in the Window Address Specification

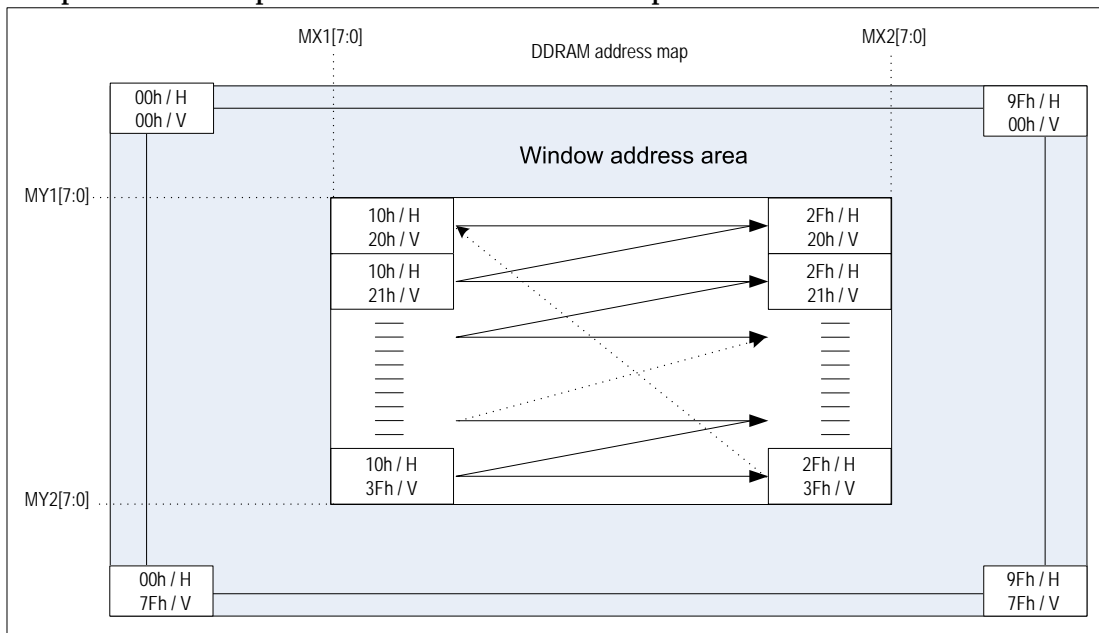

Reset Status

The SEPS525 is initialized as following description when RESETB terminal is set to "L". Usually RESETB terminal is connected reset terminal of MPU, so that the chip can be initialized simultaneously with MPU. The SEPS525 should be initialized when the power is on.

INITIAL SETTING CONDITION (default setting)

1. Frame frequency : 90Hz
2. OSC : internal OSC
3. Internal OSC : ON
4. DDRAM write horizontal address : MX1 = 00h, MX2 = 9Fh
5. DDRAM write vertical address : MY1 = 00h, MY2 = 7Fh
6. Display data RAM write : HC = 1, VC = 1, HV = 0
7. RGB data swap : OFF
8. Row scan shift direction : G0, G1, ... , G126, G127
9. Column data shift direction : S0, S1, ... , S478, S479
10. Display ON/OFF : OFF
11. Panel display size : FX1 = 00h, FX2 = 9Fh, FY1 = 00h, FY2 = 7Fh
12. Display data RAM read column/row address : FAC = 00h, FAR = 00h
13. Precharge time(R/G/B) : 0 clock
14. Precharge current(R/G/B) : 0 uA
15. Driving current(R/G/B) : 0 uA

POWER ON SEQUENCE

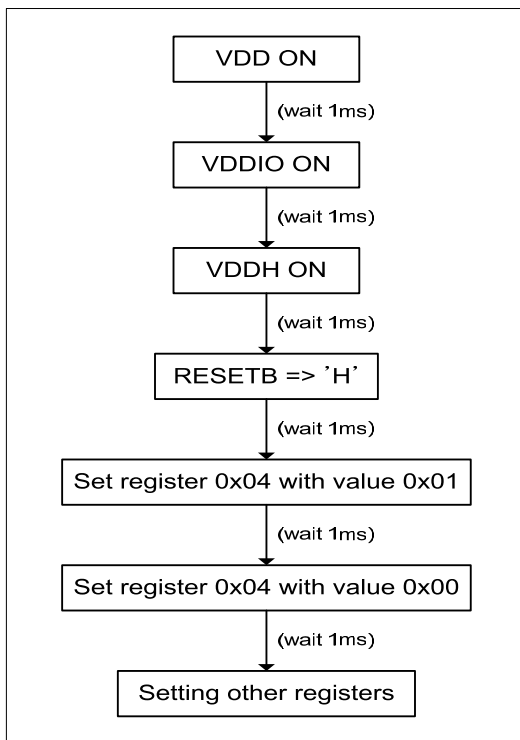

5. Instruction Description

Normal Display

ADDR	RW	IB7	IB6	IB5	IB4	IB3	IB2	IB1	IB0	Description	Default
00h	R	IDX7	IDX6	IDX5	IDX4	IDX3	IDX2	IDX1	IDX0	INDEX	00h
01h	R	HC	VC	HV	SWAP	RD	CD	DC1	DC0	STATUS_RD	C0h
02h	R/W	SELEXP	SELRES	0	0	0	0	SELCLK	OSCD5B	OSC_CTL	C0h
03h	R/W	FR3	FR2	FR1	FR0	DFR3	DFR2	DFR1	DFR0	CLOCK_DIV	30h
04h	R/W	0	0	0	0	0	RC	OSCP5	PS	REDUCE_CURRENT	00h
05h	R/W	0	0	0	0	0	0	0	SRN	SOFT_RST	00h
06h	R/W	PREM	0	0	0	0	0	0	DON	DISP_ON_OFF	00h
08h	R/W	0	0	0	0	PTR3	PTR2	PTR1	PTR0	PRECHARGE_TIME_R	00h
09h	R/W	0	0	0	0	PTG3	PTG2	PTG1	PTG0	PRECHARGE_TIME_G	00h
0Ah	R/W	0	0	0	0	PTB3	PTB2	PTB1	PTB0	PRECHARGE_TIME_B	00h
0Bh	R/W	PCR7	PCR6	PCR5	PCR4	PCR3	PCR2	PCR1	PCR0	PRECHARGE_CURRENT_R	00h
0Ch	R/W	PCG7	PCG6	PCG5	PCG4	PCG3	PCG2	PCG1	PCG0	PRECHARGE_CURRENT_G	00h
0Dh	R/W	PCB7	PCB6	PCB5	PCB4	PCB3	PCB2	PCB1	PCB0	PRECHARGE_CURRENT_B	00h
10h	R/W	DCR7	DCR6	DCR5	DCR4	DCR3	DCR2	DCR1	DCR0	DRIVING_CURRENT_R	00h
11h	R/W	DCG7	DCG6	DCG5	DCG4	DCG3	DCG2	DCG1	DCG0	DRIVING_CURRENT_G	00h
12h	R/W	DCB7	DCB6	DCB5	DCB4	DCB3	DCB2	DCB1	DCB0	DRIVING_CURRENT_B	00h
13h	R/W	SWAP	SM	RD	CD	0	SPT	DC1	DC0	DISPLAY_MODE_SET	00h
14h	R/W	0	0	RIM1	RIM0	0	0	0	EIM	RGB_IF	11h
15h	R/W	RES	RES	ENP	DOP	VSYOEN	RES	RES	RES	RGB_POL	00h
16h	R/W	0	DFM1	DFM0	TRI	0	HC	VC	HV	MEMORY_WRITE_MODE	06h
17h	R/W	MX1_7	MX1_6	MX1_5	MX1_4	MX1_3	MX1_2	MX1_1	MX1_0	MX1_ADDR	00h
18h	R/W	MX2_7	MX2_6	MX2_5	MX2_4	MX2_3	MX2_2	MX2_1	MX2_0	MX2_ADDR	9Fh
19h	R/W	MY1_7	MY1_6	MY1_5	MY1_4	MY1_3	MY1_2	MY1_1	MY1_0	MY1_ADDR	00h
1Ah	R/W	MY2_7	MY2_6	MY2_5	MY2_4	MY2_3	MY2_2	MY2_1	MY2_0	MY2_ADDR	7Fh
20h	R/W	MAC7	MAC6	MAC5	MAC4	MAC3	MAC2	MAC1	MAC0	MEMORY_ACCESS_POINTER X	00h
21h	R/W	MAR7	MAR6	MAR5	MAR4	MAR3	MAR2	MAR1	MAR0	MEMORY_ACCESS_POINTER Y	00h
22h		DDRAM[17:0]								DDRAM_DATA_ACCESS_PORT	
50h	R/W	IGAMMA7	IGAMMA6	IGAMMA5	IGAMMA4	IGAMMA3	IGAMMA2	IGAMMA1	IGAMMA0	GRAY_SCALE_TABLE_INDEX	00h
51h	R/W	DGAMMA7	DGAMMA6	DGAMMA5	DGAMMA4	DGAMMA3	DGAMMA2	DGAMMA1	DGAMMA0	GRAY_SCALE_TABLE_DATA	
28h	R/W	DUTY7	DUTY6	DUTY5	DUTY4	DUTY3	DUTY2	DUTY1	DUTY0	DUTY	7Fh
29h	R/W	DSL7	DSL6	DSL5	DSL4	DSL3	DSL2	DSL1	DSL0	DSL	00h
2Eh	R/W	FAC7	FAC6	FAC5	FAC4	FAC3	FAC2	FAC1	FAC0	D1_DDRAM_FAC	00h
2Fh	R/W	FAR7	FAR6	FAR5	FAR4	FAR3	FAR2	FAR1	FAR0	D1_DDRAM_FAR	00h
31h	R/W	SAC7	SAC6	SAC5	SAC4	SAC3	SAC2	SAC1	SAC0	D2_DDRAM_SAC	00h
32h	R/W	SAR7	SAR6	SAR5	SAR4	SAR3	SAR2	SAR1	SAR0	D2_DDRAM_SAR	00h
33h	R/W	FX1_7	FX1_6	FX1_5	FX1_4	FX1_3	FX1_2	FX1_1	FX1_0	SCR1_FX1	00h
34h	R/W	FX2_7	FX2_6	FX2_5	FX2_4	FX2_3	FX2_2	FX2_1	FX2_0	SCR1_FX2	9Fh
35h	R/W	FY1_7	FY1_6	FY1_5	FY1_4	FY1_3	FY1_2	FY1_1	FY1_0	SCR1_FY1	00h
36h	R/W	FY2_7	FY2_6	FY2_5	FY2_4	FY2_3	FY2_2	FY2_1	FY2_0	SCR1_FY2	7Fh
37h	R/W	SX1_7	SX1_6	SX1_5	SX1_4	SX1_3	SX1_2	SX1_1	SX1_0	SCR2_SX1	00h
38h	R/W	SX2_7	SX2_6	SX2_5	SX2_4	SX2_3	SX2_2	SX2_1	SX2_0	SCR2_SX2	9Fh
39h	R/W	SY1_7	SY1_6	SY1_5	SY1_4	SY1_3	SY1_2	SY1_1	SY1_0	SCR2_SY1	00h
3Ah	R/W	SY2_7	SY2_6	SY2_5	SY2_4	SY2_3	SY2_2	SY2_1	SY2_0	SCR2_SY2	7Fh
3Bh	R/W	0	SSA1	SSA0	0	SSC1	SSC0	0	SSM	SCREEN_SAVER_CONTEROL	00h
3Ch	R/W	SST7	SST6	SST5	SST4	SST3	SST2	SST1	SST0	SS_SLEEP_TIMER	00h
3Dh	R/W	0	0	SMS1	SMS0	0	0	SMF1	SMF0	SCREEN_SAVER_MODE	00h
3Eh	R/W	FSUT7	FSUT6	FSUT5	FSUT4	FSUT3	FSUT2	FSUT1	FSUT	SS_SCR1_FU	00h
3Fh	R/W	FSMS7	FSMS6	FSMS5	FSMS4	FSMS3	FSMS2	FSMS1	FSMS0	SS_SCR1_MXY	00h
40h	R/W	SSUT7	SSUT6	SSUT5	SSUT4	SSUT3	SSUT2	SSUT1	SSUT0	SS_SCR2_FU	00h
41h	R/W	SSMS7	SSMS6	SSMS5	SSMS4	SSMS3	SSMS2	SSMS1	SSMS0	SS_SCR2_MXY	00h
42h	R/W	0	0	SSMD1	SSMD0	0	0	FSMD1	FSMD0	MOVING_DIRECTION	00h
47h	R/W	ISX1_7	ISX1_6	ISX1_5	ISX14	ISX1_3	ISX1_2	ISX1_1	ISX1_0	SS_SCR2_SX1	00h
48h	R/W	ISX2_7	ISX2_6	ISX2_5	ISX2_4	ISX2_3	ISX2_2	ISX2_1	ISX2_0	SS_SCR2_SX2	00h
49h	R/W	ISY1_7	ISY1_6	ISY1_5	ISY1_4	ISY1_3	ISY1_2	ISY1_1	ISY1_0	SS_SCR2_SY1	00h
4Ah	R/W	ISY2_7	ISY2_6	ISY2_5	ISY2_4	ISY2_3	ISY2_2	ISY2_1	ISY2_0	SS_SCR2_SY2	00h

INDEX (00h)

R/W	Bit 7	Bit6	Bit5	Bit4	Bit3	Bit2	Bit1	Bit0
R	IDX7	IDX6	IDX5	IDX4	IDX3	IDX2	IDX1	IDX0

IDX[7:0] : Index address of registers.

STATUS_RD (01h)

	Bit 7	Bit6	Bit5	Bit4	Bit3	Bit2	Bit1	Bit0
R	HC	VC	HV	SWAP	RD	CD	DC1	DC0
Default	1	1	0	0	0	0	0	0

The status read instruction reads the internal status of the SEPS525.

HC : Horizontal address increment/decrement at memory write mode.

VC : Vertical address increment/decrement at memory write mode.

HV : Automatic update method of the AC(means internal address counter).

HV=0(horizontal), HV=1(vertical)

SWAP : Swap between R and B.

RD : Row scan shift direction.

CD : Column data shift direction.

DC[1:0] : Display data output control.

OSC_CTL (02h)

	Bit 7	Bit6	Bit5	Bit4	Bit3	Bit2	Bit1	Bit0
R/W	SELEXP	SELRES	-	-	-	-	SELCLK	OSCDSB
Default	1	1	0	0	0	0	0	0

SELEXP : OSC

When SELEXP = 0, EXPORT1 internal clock

When SELEXP = 1, EXPORT1 "0" level

SELRES : Internal oscillator mode selection.

When SELRES = 0, Oscillator operates with external resistor

When SELRES = 1, Oscillator operates with internal resistor

SELCLK, OSCDSB :

SELCLK	OSCDSB	
X	0	CLOCK OFF
0	1	Internal OSC ON
1	1	External CLK mode

IREF (80h)

	Bit 7	Bit6	Bit5	Bit4	Bit3	Bit2	Bit1	Bit0
R/W	-	-	-	-	-	-	-	IREF
Default	0	0	0	0	0	0	0	0

IREF : Control reference voltage generation.

When IREF = 0, Reference voltage controlled by external resistor

When IREF = 1, Reference voltage controlled by internal resistor

CLOCK_DIV (03h)

	Bit 7	Bit6	Bit5	Bit4	Bit3	Bit2	Bit1	Bit0
R/W	FR3	FR2	FR1	FR0	DFR3	DFR2	DFR1	DFR0
Default	0	0	1	1	0	0	0	0

FR[3:0] : OSC frequency setting.

FR3	FR2	FR1	FR0	Frame Rate
0	0	0	0	75 Hz
0	0	0	1	80 Hz
0	0	1	0	85 Hz
0	0	1	1	90 Hz
0	1	0	0	95 Hz
0	1	0	1	100 Hz
0	1	1	0	105 Hz
0	1	1	1	110 Hz

FR3	FR2	FR1	FR0	Frame Rate
1	0	0	0	115 Hz
1	0	0	1	120 Hz
1	0	1	0	125 Hz
1	0	1	1	130 Hz
1	1	0	0	135 Hz
1	1	0	1	140 Hz
1	1	1	0	145 Hz
1	1	1	1	150 Hz

DFR[3:0] : Display frequency divide ration.

DFR3	DFR2	DFR1	DFR0	OSC CLK
0	0	0	0	1
0	0	0	1	1
0	0	1	0	1/2
0	0	1	1	1/3
0	1	0	0	1/4
0	1	0	1	1/5
0	1	1	0	1/6
0	1	1	1	1/7

DFR3	DFR2	DFR1	DFR0	OSC CLK
1	0	0	0	1/8
1	0	0	1	1/9
1	0	1	0	1/10
1	0	1	1	1/11
1	1	0	0	1/12
1	1	0	1	1/13
1	1	1	0	1/14
1	1	1	1	1/15

REDUCE_CURRENT (04h)

	Bit 7	Bit6	Bit5	Bit4	Bit3	Bit2	Bit1	Bit0
R/W	-	-	-	-	-	RC	OSCPS	PS
Default	0	0	0	0	0	0	0	0

RC : Reduced driving current.

When RC = 0, Normal

When RC = 1, 1/2driving current(address 0x10, 0x11, 0x12)

OSCPS : Oscillator power down

When OSCPS = 0, Normal

When OSCPS = 1, Internal oscillator power off

PS : Power save mode.

When PS = 0, normal

When PS = 1, display off, analog reset

SOFT_RST (05h)

	Bit 7	Bit6	Bit5	Bit4	Bit3	Bit2	Bit1	Bit0
R/W	-	-	-	-	-	-	-	SRN
Default	0	0	0	0	0	0	0	0

SRN : Soft reset active high.

When SRN = 0, normal mode

When SRN = 1, all internal register value will be default

DISP_ON_OFF (06h)

	Bit 7	Bit6	Bit5	Bit4	Bit3	Bit2	Bit1	Bit0
R/W	PREM	-	-	-	-	-	-	DON
Default	0	0	0	0	0	0	0	0

PREM : Precharge mode select.

When PREM = 0, Scan signal is high level at pre_charge period

When PREM = 1, Scan signal is low level at pre_charge period

DON : Display ON/OFF.

When DON = 0, Turns the display off

When DON = 1, Turns the display on

PRECHARGE_TIME_R (08h)

	Bit 7	Bit6	Bit5	Bit4	Bit3	Bit2	Bit1	Bit0
R/W	-	-	-	-	PTR3	PTR2	PTR1	PTR0
Default	0	0	0	0	0	0	0	0

PRECHARGE_TIME_G (09h)

	Bit 7	Bit6	Bit5	Bit4	Bit3	Bit2	Bit1	Bit0
R/W	-	-	-	-	PTG3	PTG2	PTG1	PTG0
Default	0	0	0	0	0	0	0	0

PRECHARGE_TIME_B (0Ah)

	Bit 7	Bit6	Bit5	Bit4	Bit3	Bit2	Bit1	Bit0
R/W	-	-	-	-	PTB3	PTB2	PTB1	PTB0
Default	0	0	0	0	0	0	0	0

PTR[3:0] : Precharge time R.

PTG[3:0] : Precharge time G.

PTB[3:0] : Precharge time B.

* PTR[3:0]/PTG[3:0]/PTB[3:0] is used for precharge time selection of Red/Green/Blue pixel.
The range is from 0 to 15 based on internal OSC.

PTR3/ PRG3/ PRB3	PTR2/ PRG2/ PRB2	PTR1/ PRG1/ PRB1	PTR0/ PRG0/ PRB0	Precharge Time (CLK)
0	0	0	0	No Precharge Time (Clk)
0	0	0	1	1 Precharge Time (Clk)
0	0	1	0	2 Precharge Time (Clk)
0	0	1	1	3 Precharge Time (Clk)
0	1	0	0	4 Precharge Time (Clk)
0	1	0	1	5 Precharge Time (Clk)
0	1	1	0	6 Precharge Time (Clk)
0	1	1	1	7 Precharge Time (Clk)
1	0	0	0	8 Precharge Time (Clk)
1	0	0	1	9 Precharge Time (Clk)
1	0	1	0	10 Precharge Time (Clk)
1	0	1	1	11 Precharge Time (Clk)
1	1	0	0	12 Precharge Time (Clk)
1	1	0	1	13 Precharge Time (Clk)
1	1	1	0	14 Precharge Time (Clk)
1	1	1	1	15 Precharge Time (Clk)

PRECHARGE_CURRENT_R (0Bh)

	Bit 7	Bit6	Bit5	Bit4	Bit3	Bit2	Bit1	Bit0
R/W	PCR7	PCR6	PCR5	PCR4	PCR3	PCR2	PCR1	PCR0
Default	0	0	0	0	0	0	0	0

PRECHARGE_CURRENT_G (0Ch)

	Bit 7	Bit6	Bit5	Bit4	Bit3	Bit2	Bit1	Bit0
R/W	PCG7	PCG6	PCG5	PCG4	PCG3	PCG2	PCG1	PCG0
Default	0	0	0	0	0	0	0	0

PRECHARGE_CURRENT_B (0Dh)

	Bit 7	Bit6	Bit5	Bit4	Bit3	Bit2	Bit1	Bit0
R/W	PCB7	PCB6	PCB5	PCB4	PCB3	PCB2	PCB1	PCB
Default	0	0	0	0	0	0	0	0

PCR[7:0] : Precharge current R.

PCG[7:0] : Precharge current G.

PCB[7:0] : Precharge current B.

* Precharge current = setting value * 8uA.

DRIVING_CURRENT_R (10h)

	Bit 7	Bit6	Bit5	Bit4	Bit3	Bit2	Bit1	Bit0
R/W	DCR7	DCR6	DCR5	DCR4	DCR3	DCR2	DCR1	DCR0
Default	0	0	0	0	0	0	0	0

DRIVING_CURRENT_G (11h)

	Bit 7	Bit6	Bit5	Bit4	Bit3	Bit2	Bit1	Bit0
R/W	DCG7	DCG6	DCG5	DCG4	DCG3	DCG2	DCG1	DCG0
Default	0	0	0	0	0	0	0	0

DRIVING_CURRENT_B (12h)

	Bit 7	Bit6	Bit5	Bit4	Bit3	Bit2	Bit1	Bit0
R/W	DCB7	DCB6	DCB5	DCB4	DCB3	DCB2	DCB1	DCB0
Default	0	0	0	0	0	0	0	0

DCR[7:0] : DCR driving current R.

DCG[7:0] : DCG driving current G.

DCB[7:0] : DCB driving current B.

* Driving current = setting value * 1uA.

DISPLAY_MODE_SET(13h)

	Bit 7	Bit6	Bit5	Bit4	Bit3	Bit2	Bit1	Bit0
R/W	SWAP	SM	RD	CD	-	SPT	DC1	DC0
Default	0	0	0	0	0	0	0	0

SWAP : RGB swap.

	SWAP = 0			SWAP = 1		
Input	R	G	B	R	G	B
Output	R	G	B	B	G	R

SM : Scan mode.

RD : Row scan shift direction.

SM	RD	G[127:0]										
0	0	0	1	2	...					125	126	127
0	1	127	126	125	...					2	1	0
1	0	0	2	4	...	126	1	3	...	125	127	
1	1	127	125	123	...	1	126	124	...	2	0	

CD : Column data shift direction.

When CD= 0, D0 to D159 shift

When CD= 1, D159 to D0 shift

SPT : Split

When SPT = 0, One screen mode

When SPT = 1, Two screen mode

DC[1:0] : Column data display control.

DC1	DC0	Data Output
0	0	Normal Display(default)
0	1	All Low Display
1	0	All High Display
1	1	Reserved

RGB_IF (14h)

	Bit 7	Bit6	Bit5	Bit4	Bit3	Bit2	Bit1	Bit0
R/W	-	-	RIM1	RIM0	-	-	-	EIM
Default	0	0	0	1	0	0	0	1

RIM[1:0] : RGB interface mode.

RIM1	RIM0	Result
0	0	18_Bit RGB interface
0	1	16_Bit RGB interface
1	0	6_Bit RGB interface
1	1	Reserved

EIM : External interface mode.

When EIM = 0, RGB

When EIM = 1, MPU

RGB_POL (15h)

	Bit 7	Bit6	Bit5	Bit4	Bit3	Bit2	Bit1	Bit0
R/W	RES	RES	ENP	DOP	VSYOEN	RES	RES	RES
Default	0	0	0	0	0	0	0	0

VSYOEN : Vsync. Output enable(0 : VSYNCO disable).

DOP : Dot clock polarity(0 : sampled at rising edge).

ENP : Enable polarity(0 : active low).

Note) All reserved signals(RES) must write to '0'.

MEMORY_WRITE_MODE (16h)

	Bit 7	Bit6	Bit5	Bit4	Bit3	Bit2	Bit1	Bit0
R/W	-	DFM1	DFM0	TRI	-	HC	VC	HV
Default	0	0	0	0	0	1	1	0

DFM[1:0],TRI :

DFM1	DFM0	TRI	BIT	Result
0	0	X	18_bit	Single transfer, 262k support
0	1	X	16_bit	Single transfer, 65k support
1	0	X	9_bit	Dual transfer, 262k support
1	1	0	8_bit	Dual transfer, 65k support
1	1	1	8_bit	Triple transfer, 262k support

HC : Horizontal address increment/decrement.

When HC= 0, Horizontal address counter is decreased

When HC= 1, Horizontal address counter is increased

VC : Vertical address increment/decrement.

When VC= 0, Vertical address counter is decreased

When VC= 1, Vertical address counter is increased

HV : Set the automatic update method of the AC after the data is written to the DDRAM.

When HV= 0, The data is continuously written horizontally

When HV= 1, The data is continuously written vertically

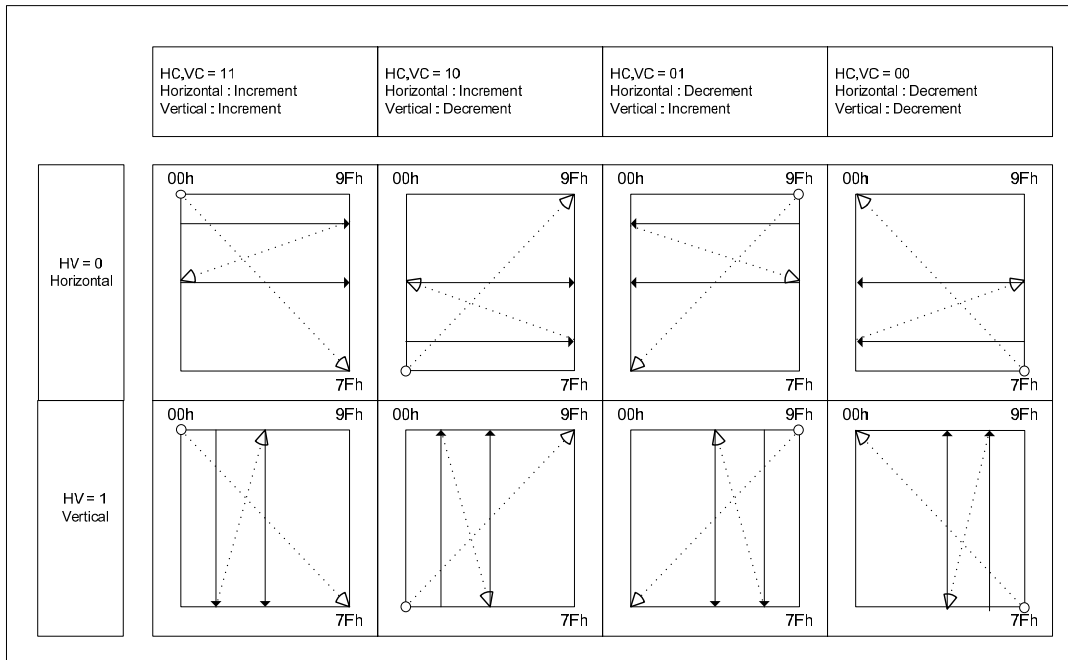

MX1_ADDR (17h)

	Bit 7	Bit6	Bit5	Bit4	Bit3	Bit2	Bit1	Bit0
R/W	MX1_7	MX1_6	MX1_5	MX1_4	MX1_3	MX1_2	MX1_1	MX1_0
Default	0	0	0	0	0	0	0	0

MX2_ADDR (18h)

	Bit 7	Bit6	Bit5	Bit4	Bit3	Bit2	Bit1	Bit0
R/W	MX2_7	MX2_6	MX2_5	MX2_4	MX2_3	MX2_1	MX2_1	MX2_0
Default	1	0	0	1	1	1	1	1

MY1_ADDR (19h)

	Bit 7	Bit6	Bit5	Bit4	Bit3	Bit2	Bit1	Bit0
R/W	MY1_7	MY1_6	MY1_5	MY1_4	MY1_3	MY1_2	MY1_1	MY1_0
Default	0	0	0	0	0	0	0	0

MY2_ADDR (1Ah)

	Bit 7	Bit6	Bit5	Bit4	Bit3	Bit2	Bit1	Bit0
R/W	MY2_7	MY2_6	MY2_5	MY2_4	MY2_3	MY2_1	MY2_1	MY2_0
Default	0	1	1	1	1	1	1	1

MX1[7:0] / MX2[7:0]

Specify the horizontal start/end position of a window for access in memory. Data can be written to DDRAM from the address specified by MX1[7:0] to the address specified by MX2[7:0].

MY1[7:0] / MY2[7:0]

Specify the vertical start/end position of a window for access in memory. Data can be written to DDRAM from the address specified by MY1[7:0] to the address specified by MY2[7:0].

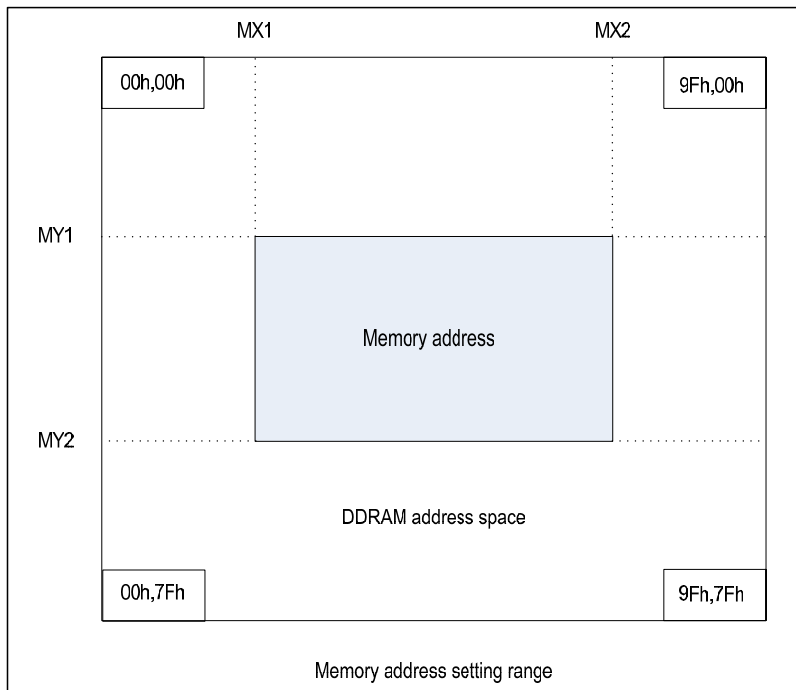

MEMORY_ACCESSPOINTER X (20h)

	Bit 7	Bit6	Bit5	Bit4	Bit3	Bit2	Bit1	Bit0
R/W	MAC7	MAC6	MAC5	MAC4	MAC3	MAC2	MAC1	MAC0
Default	0	0	0	0	0	0	0	0

MEMORY_ACCESSPOINTER Y (21h)

	Bit 7	Bit6	Bit5	Bit4	Bit3	Bit2	Bit1	Bit0
R/W	MAR7	MAR6	MAR5	MAR4	MAR3	MAR2	MAR1	MAR0
Default	0	0	0	0	0	0	0	0

MAC[7:0] / MAR[7:0]

Specify the horizontal start/vertical start position of a window for write in memory

Data can be written to DDRAM from MAC[7:0]/MAR7:0] to MX2[7:0]/MY2[7:0]

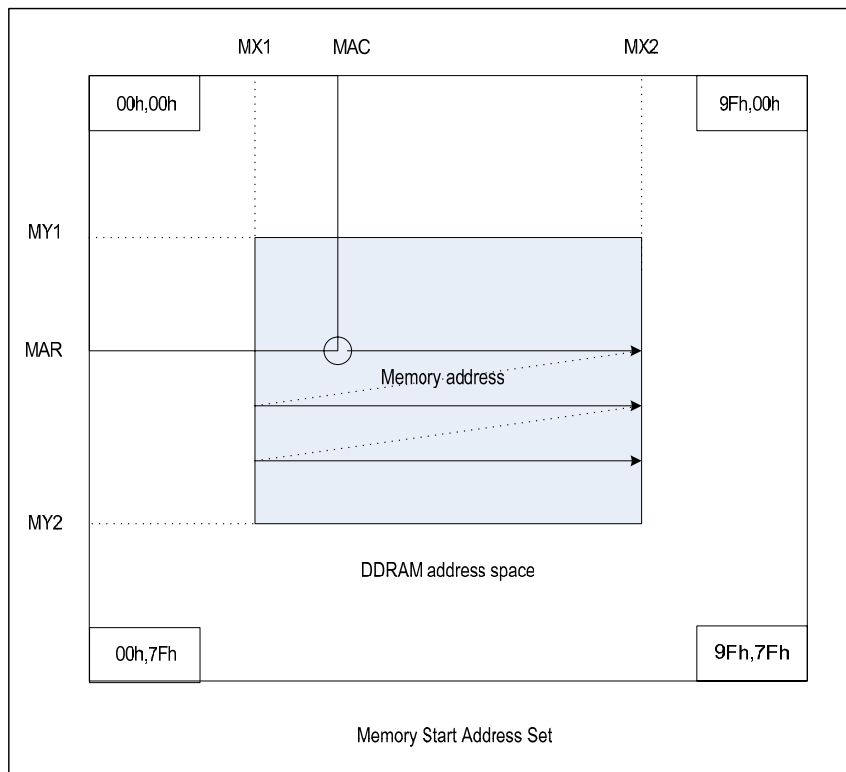

DDRAM_DATA_ACCESS_PORT (22h)

	Bit 17	Bit16	Bit15	Bit14	Bit13	Bit12	Bit11	Bit10	Bit9	Bit8	Bit7	Bit6	Bit5	Bit4	Bit3	Bit2	Bit1	Bit0
R/W	DB17	DB16	DB15	DB14	DB13	DB12	DB11	DB10	DB9	DB8	DB7	DB6	DB5	DB4	DB3	DB2	DB1	DB0
Default	R						G						B					

DDRAM[17:0] : After index register 22h is select, Internal DDRAM memory can be accessed.

GRAY_SCALE_TABLE_INDEX (50h)

	Bit 7	Bit6	Bit5	Bit4	Bit3	Bit2	Bit1	Bit0
R/W	IGAMMA7	IGAMMA6	IGAMMA5	IGAMMA4	IGAMMA3	IGAMMA2	IGAMMA1	IGAMMA0
Default	0	0	0	0	0	0	0	0

IGAMMA[7:0] : Index register for gamma table.
There are 32 entry of odd IGAMMA.

GRAY_SCALE_TABLE_DATA (51h)

	Bit 7	Bit6	Bit5	Bit4	Bit3	Bit2	Bit1	Bit0
R/W	DGAMMA7	DGAMMA6	DGAMMA5	DGAMMA4	DGAMMA3	DGAMMA2	DGAMMA1	DGAMMA0

DGAMMA[7:0] : Data register for gamma table.

If DGAMMA is even, $DGAMMA_n = (DGAMMA_{n-1} + DGAMMA_{n+1})/2$

DGAMMA RED (Index Register 00H ~ 1FH)

Index Register	IGAMMA	Reset Value
00h	1	1
01h	3	5
02h	5	9
⋮	⋮	⋮
⋮	⋮	⋮
⋮	⋮	⋮
1Eh	61	121
1Fh	63	125

DGAMMA GREEN (Index Register 20H ~ 3FH)

Index Register	IGAMMA	Reset Value
20h	1	1
21h	3	5
22h	5	9
⋮	⋮	⋮
⋮	⋮	⋮
⋮	⋮	⋮
3Eh	61	121
3Fh	63	125

DGAMMA BLUE (Index Register 40H ~ 5FH)

Index Register	IGAMMA	Reset Value
40h	1	1
41h	3	5
42h	5	9
⋮	⋮	⋮
⋮	⋮	⋮
⋮	⋮	⋮
5Eh	61	121
5Fh	63	125

DUTY (28h)

	Bit 7	Bit6	Bit5	Bit4	Bit3	Bit2	Bit1	Bit0
R/W	DUTY7	DUTY6	DUTY5	DUTY4	DUTY3	DUTY2	DUTY1	DUTY0
Default	0	1	1	1	1	1	1	1

DUTY[7:0] : Display duty ratio(16~127).

DSL (29h)

	Bit 7	Bit6	Bit5	Bit4	Bit3	Bit2	Bit1	Bit0
R/W	DSL7	DSL6	DSL5	DSL4	DSL3	DSL2	DSL1	DSL0
Default	0	0	0	0	0	0	0	0

DSL[7:0] : Display start line(0~127-16).

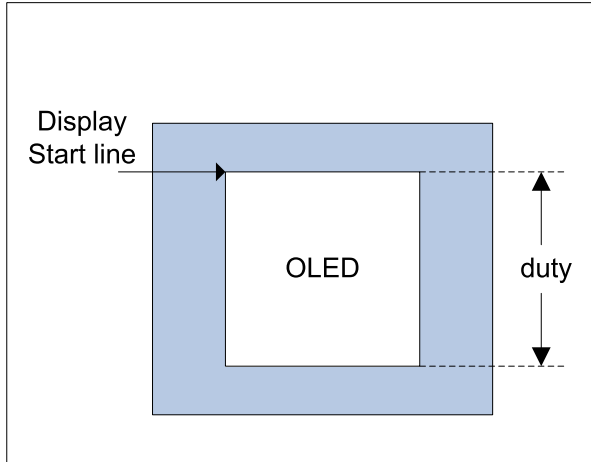

D1_DDRAM_FAC (2Eh)

	Bit 7	Bit6	Bit5	Bit4	Bit3	Bit2	Bit1	Bit0
R/W	FAC7	FAC6	FAC5	FAC4	FAC3	FAC2	FAC1	FAC0
Default	0	0	0	0	0	0	0	0

D1_DDRAM_FAR (2Fh)

	Bit 7	Bit6	Bit5	Bit4	Bit3	Bit2	Bit1	Bit0
R/W	FAR7	FAR6	FAR5	FAR4	FAR3	FAR2	FAR1	FAR0
Default	0	0	0	0	0	0	0	0

FAC[7:0] : First screen display horizontal address for display.

FAR[7:0] : First screen display vertical address for display.

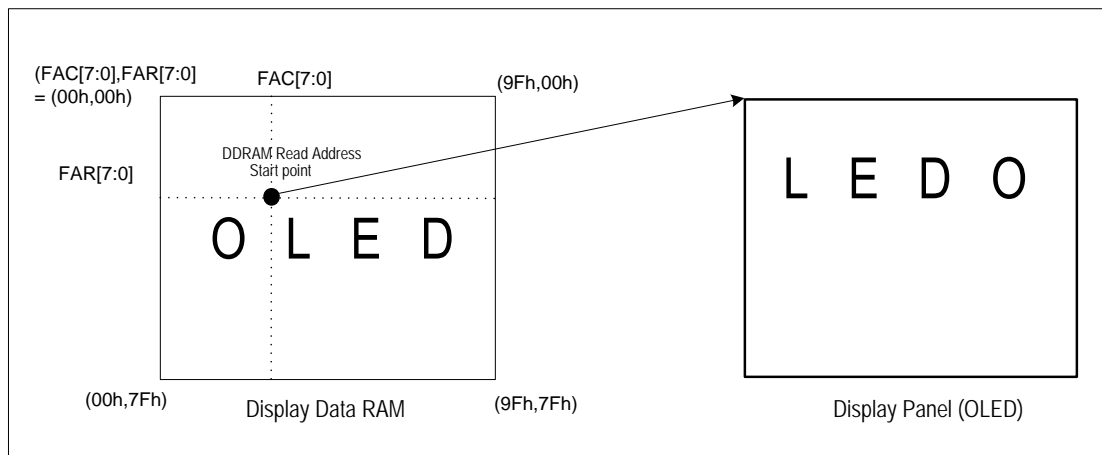
**D2_DDRAM_SAC (31h)**

	Bit 7	Bit6	Bit5	Bit4	Bit3	Bit2	Bit1	Bit0
R/W	SAC7	SAC6	SAC5	SAC4	SAC3	SAC2	SAC1	SAC0
Default	0	0	0	0	0	0	0	0

D2_DDRAM_SAR (32h)

	Bit 7	Bit6	Bit5	Bit4	Bit3	Bit2	Bit1	Bit0
R/W	SAR7	SAR6	SAR5	SAR4	SAR3	SAR2	SAR1	SAR0
Default	0	0	0	0	0	0	0	0

SAC[7:0] : Second screen display horizontal address for display.

SAR[7:0] : Second screen display vertical address for display.

SCR1_FX1 (33h)

	Bit 7	Bit6	Bit5	Bit4	Bit3	Bit2	Bit1	Bit0
R/W	FX1_7	FX1_6	FX1_5	FX1_4	FX1_3	FX1_2	FX1_1	FX1_0
Default	0	0	0	0	0	0	0	0

SCR1_FX2 (34h)

	Bit 7	Bit6	Bit5	Bit4	Bit3	Bit2	Bit1	Bit0
R/W	FX2_7	FX2_6	FX2_5	FX2_4	FX2_3	FX2_2	FX2_1	FX2_0
Default	1	0	0	1	1	1	1	1

SCR1_FY1 (35h)

	Bit 7	Bit6	Bit5	Bit4	Bit3	Bit2	Bit1	Bit0
R/W	FY1_7	FY1_6	FY1_5	FY1_4	FY1_3	FY1_2	FY1_1	FY1_0
Default	0	0	0	0	0	0	0	0

SCR1_FY2 (36h)

	Bit 7	Bit6	Bit5	Bit4	Bit3	Bit2	Bit1	Bit0
R/W	FY2_7	FY2_6	FY2_5	FY2_4	FY2_3	FY2_2	FY2_1	FY2_0
Default	0	1	1	1	1	1	1	1

FX1[7:0] / FX2[7:0] : The start/end address of active column outputs for the first screen (00h ~ 9Fh).
(FX1[7:0] < FX2[7:0])

FY1[7:0] / FY2[7:0] : The start/end address of active row outputs for the second screen (00h ~ 7Fh).
(FY1[7:0] < FY2[7:0])

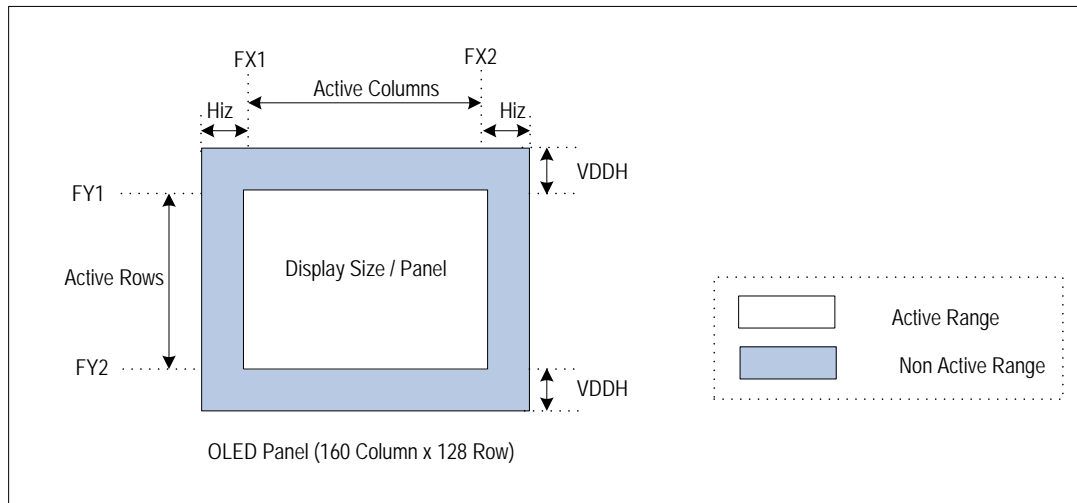

The row outputs out of active area are always VDDH excluding display off.

SCR2_SX1 (37h)

	Bit 7	Bit6	Bit5	Bit4	Bit3	Bit2	Bit1	Bit0
R/W	SX1_7	SX1_6	SX1_5	SX1_4	SX1_3	SX1_2	SX1_1	SX1_0
Default	0	0	0	0	0	0	0	0

SCR2_SX2 (38h)

	Bit 7	Bit6	Bit5	Bit4	Bit3	Bit2	Bit1	Bit0
R/W	SX2_7	SX2_6	SX2_5	SX2_4	SX2_3	SX2_2	SX2_1	SX2_0
Default	1	0	0	1	1	1	1	1

SCR2_SY1 (39h)

	Bit 7	Bit6	Bit5	Bit4	Bit3	Bit2	Bit1	Bit0
R/W	SY1_7	SY1_6	SY1_5	SY1_4	SY1_3	SY1_2	SY1_1	SY1_0
Default	0	0	0	0	0	0	0	0

SCR2_SY2 (3Ah)

	Bit 7	Bit6	Bit5	Bit4	Bit3	Bit2	Bit1	Bit0
R/W	SY2_7	SY2_6	SY2_5	SY2_4	SY2_3	SY2_2	SY2_1	SY2_0
Default	0	1	1	1	1	1	1	1

SX1[7:0] : 2nd Screen display size horizontal start.

SX2[7:0] : 2nd Screen display size horizontal end.

SY1[7:0] : 2nd Screen display size vertical start.

SY2[7:0] : 2nd Screen display size vertical end.

SCREEN_SAVER_CONTEROL (3Bh)

	Bit 7	Bit6	Bit5	Bit4	Bit3	Bit2	Bit1	Bit0
R/W	-	SSA1	SSA0	-	SSC1	SSC0	-	SSM
Default	0	0	0	0	0	0	0	0

SSA[1:0] : 1st, 2nd Screen auto sleep saver.

SSA1	SSA0	2 nd Screen	1 st Screen
0	0	OFF	OFF
0	1	OFF	ON
1	0	ON	OFF
1	1	ON	ON

SSC[1:0] : 1st, 2nd Screen on/off saver control.

SSC1	SSC0	2 nd Screen	1 st Screen
0	0	OFF	OFF
0	1	OFF	ON
1	0	ON	OFF
1	1	ON	ON

SSM : Screen Saver Mode on/off(0: off, 1: on).

When SSM= 0, Screen Saver mode OFF(default)

When SSM= 1, Screen saver mode ON

SS_SLEEP_TIMER (3Ch)

	Bit 7	Bit6	Bit5	Bit4	Bit3	Bit2	Bit1	Bit0
R/W	SST7	SST6	SST5	SST4	SST3	SST2	SST1	SST0
Default	0	0	0	0	0	0	0	0

SST [7:0] : Screen saver sleep timer.

Note) Based on 64 frames sync.

Ex) when setting value = 10 :

Screen saver will enter sleep mode after 10*64 frame display.

SCREEN_SAVER_MODE (3Dh)

	Bit 7	Bit 6	Bit 5	Bit 4	Bit 3	Bit 2	Bit 1	Bit 0
R/W	-	-	SMS1	SMS0	-	-	SMF1	SMF0
Default	0	0	0	0	0	0	0	0

SMF[1:0] : 1st Screen mode set.

SMF1	SMF0	1 st Screen
0	0	Reserved
0	1	Left Panning
1	0	Right Panning
1	1	Reserved

SMS[1:0] : 2nd Screen mode set.

SMS1	SMS0	2 nd Screen
0	0	Box move
0	1	Log on
1	0	Reserved
1	1	Wrap_around

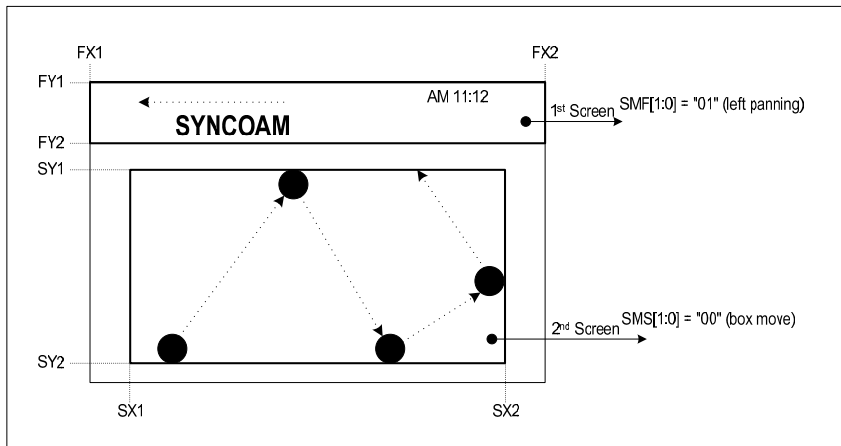

SS_SCR1_FU (3Eh)

	Bit 7	Bit6	Bit5	Bit4	Bit3	Bit2	Bit1	Bit0
R/W	FSUT7	FSUT6	FSUT5	FSUT4	FSUT3	FSUT2	FSUT1	FSUT0
Default	0	0	0	0	0	0	0	0

FSUT[7:0] : 1st Screen update timer based on frame sync.

SS_SCR1_MXY (3Fh)

	Bit 7	Bit6	Bit5	Bit4	Bit3	Bit2	Bit1	Bit0
R/W	FSMS7	FSMS6	FSMS5	FSMS4	FSMS3	FSMS2	FSMS1	FSMS0
Default	0	0	0	0	0	0	0	0

FSMS[7:0] : 1st Screen moving step.

FSMS[7:4] : Vertical moving step.

FSMS[3:0] : Horizontal moving step.

SS_SCR2_FU (40h)

	Bit 7	Bit6	Bit5	Bit4	Bit3	Bit2	Bit1	Bit0
R/W	SSUT7	SSUT6	SSUT5	SSUT4	SSUT3	SSUT2	SSUT1	SSUT0
Default	0	0	0	0	0	0	0	0

SSUT[7:0] : 2nd Screen update timer based on frame sync.

SS_SCR2_MXY (41h)

	Bit 7	Bit6	Bit5	Bit4	Bit3	Bit2	Bit1	Bit0
R/W	SSMS7	SSMS6	SSMS5	SSMS4	SSMS3	SSMS2	SSMS1	SSMS0
Default	0	0	0	0	0	0	0	0

SSMS[7:0] : 2nd Screen moving step.

SSMS[7:4] : Vertical moving step.

SSMS[3:0] : Horizontal moving step.

MOVING_DIRECTION (42h)

	Bit 7	Bit6	Bit5	Bit4	Bit3	Bit2	Bit1	Bit0
R/W	-	-	SSMD1	SSMD0	-	-	FSMD1	FSMD0
Default	0	0	0	0	0	0	0	0

FSMD[1:0] : 1st Screen moving direction.

FSMD1	FSMD0	1 st Screen
0	0	UP, LEFT
0	1	UP, RIGHT
1	0	DOWN, LEFT
1	1	DOWN, RIGHT

SSMD[1:0] : 2nd Screen moving direction.

SSMD1	SSMD0	2 nd Screen
0	0	UP, LEFT
0	1	UP, RIGHT
1	0	DOWN, LEFT
1	1	DOWN, RIGHT

SS_SCR2_SX1 (47h)

	Bit 7	Bit6	Bit5	Bit4	Bit3	Bit2	Bit1	Bit0
R/W	ISX1_7	ISX1_6	ISX1_5	ISX1_4	ISX1_3	ISX1_2	ISX1_1	ISX1_0
Default	0	0	0	0	0	0	0	0

SS_SCR2_SX2 (48h)

	Bit 7	Bit6	Bit5	Bit4	Bit3	Bit2	Bit1	Bit0
R/W	ISX2_7	ISX2_6	ISX2_5	ISX2_4	ISX2_3	ISX2_2	ISX2_1	ISX2_0
Default	0	0	0	0	0	0	0	0

SS_SCR2_SY1 (49h)

	Bit 7	Bit6	Bit5	Bit4	Bit3	Bit2	Bit1	Bit0
R/W	ISY1_7	ISY1_6	ISY1_5	ISY1_4	ISY1_3	ISY1_2	ISY1_1	ISY1_0
Default	0	0	0	0	0	0	0	0

SS_SCR2_SY2 (4Ah)

	Bit 7	Bit6	Bit5	Bit4	Bit3	Bit2	Bit1	Bit0
R/W	ISY2_7	ISY_6	ISY2_5	ISY2_4	ISY2_3	ISY2_2	ISY2_1	ISY2_0
Default	0	0	0	0	0	0	0	0

ISX1[7:0] : 2nd Screen image box horizontal start address.

ISX2[7:0] : 2nd Screen image box horizontal end address.

ISY1[7:0] : 2nd Screen image box vertical start address.

ISY2[7:0] : 2nd Screen image box vertical end address.

6. Electric Characteristics

1) Absolute Maximum Rating

ITEM	SYMBOL	CONDITION	PORT	RATINGS	UNIT
Supply voltage	VDD	VSS/VSSH/ VDSH(0V) Reference Ta = +25°C	VDD	- 0.3 ~ +4.0	V
	VDDH		VDDH	- 0.3 ~ +19.5	V
	VDDIO		VDDIO	- 0.3 ~ +4.0	V
Input voltage	VI		*1	- 0.3 ~ +VDD+0.3	V
Storage temperature	Tstg			- 65 ~ +150	°C

*1 : DB[17:0], CPU, PS, CSB, RS, RDB, WRB, RESETB.

2) Recommended Operation Conditions

ITEM	SYMBOL	PORT	MIN	TYP	MAX	UNIT	REMARK
Supply voltage	VDD	VDD	2.4	2.8	3.3	V	
	VDDH	VDDH	8.0	16	18.0	V	
	VDDIO	VDDIO	1.6	-	3.3	V	
Operating voltage	VDC	S[479:0]	0	16	18.0	V	
Operation temperature	Topr		- 40		85	°C	

3) DC Characteristics

ITEM	SYMBOL	CONDITION	MIN	TYP	MAX	UNIT	PORT
High level input voltage	VIH			0.8XVDD	VDD	V	
Low level input voltage	VIL			0	0.4	V	
High level output voltage	VOH1	IOH = -0.4mA			VDD-0.4	V	
Low level output voltage	VOL1	IOL = -0.4mA			0.4	V	
High level output voltage	VOH2	IOH = -0.1mA			VDD-0.4	V	
Low level output voltage	VOL2	IOL = -0.1mA			0.4	V	
Input leakage current	ILI	VI = VSS or VDD	-1		1	uA	
Output leakage current	ILO	VI = VSS or VDD	-1		1	uA	
Static current (1)	ISB	CSB = VDD, VDD = 2.8V Ta = 25°C			TBD	uA	
Static current (2)	SITBP	CSB = VDD, VDD = 2.8V Ta = 25°C, Power save mode			TBD	uA	
Current Consumption (1)	IVDD1	VDD = 2.8V IDC = 200uA			TBD	uA	
Current Consumption (2)	IVDD2	VDD = 2.8V IDC = 100uA			TBD	uA	
Current Consumption (3)	IVDD3	VDD = 2.8V IDC = 50uA			TBD	uA	
Oscillator frequency	FOSC1	VDD = 2.8V Ta = 25°C		TBD	TBD	MHz	
Oscillator frequency By external resistor	FSO1	RF = TBDkΩ		TBD	TBD	MHz	
Frame scan rate	Frame	VDD = 2.8V, Ta = 25°C	75	90	150	Hz	
Column output current range	IDC	4 < VDC < VDDH -2V	0		255	uA	
Column output current match	IDCM	4 < VDC < VDDH -2V			±3	%	
Row switch on current sink	IDR	Common is on, IDR=TBDuA, PWM TBDcks			120	mA	
Row switch on resistance	RDR	Common is on, VDC IFM = 30 mA		20	25	Ω	

4) AC Characteristics

4-1) System BUS Read/Write Timing (80 series CPU interface)

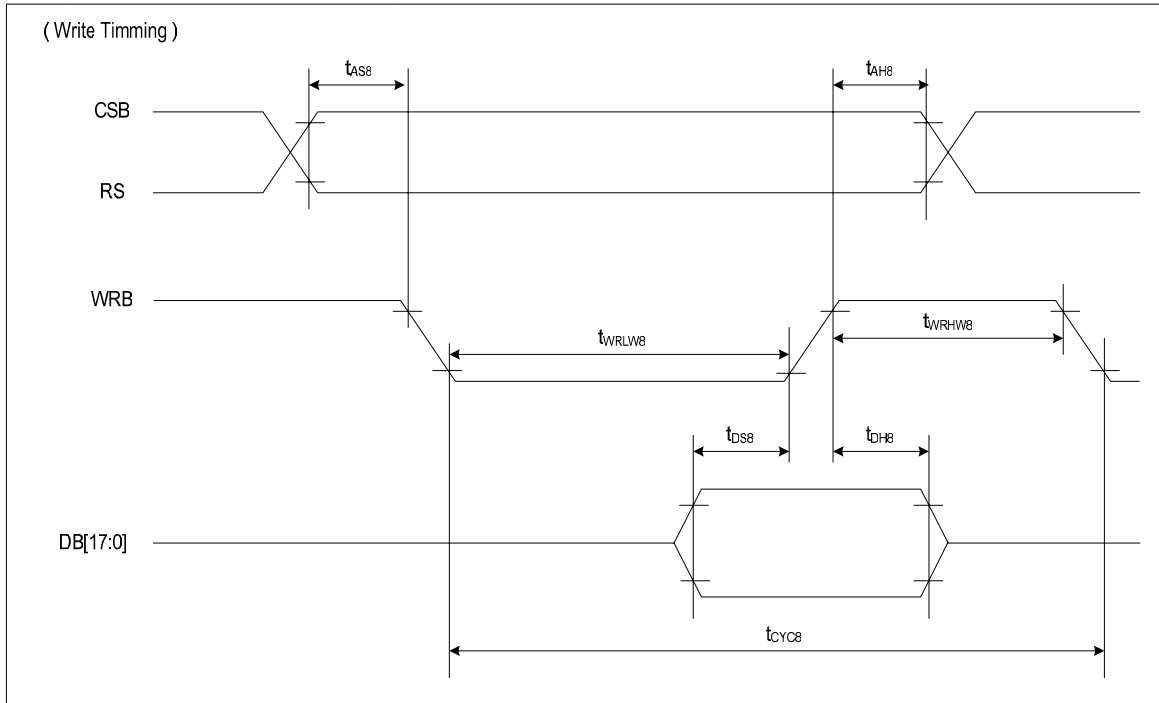

(VDD = 2.8V, Ta = 25°C)

ITEM	SYMBOL	CONDITION	MIN	MAX	UNIT	PORT
Address hold timing	t_{AH8}	-	5	-	ns	CSB
Address setup timing	t_{Ass}	-	5	-	ns	RS
System cycle timing	t_{CYCS}	-	100	-	ns	WRB
Write "L" pulse width	t_{WRLW8}	-	45	-	ns	WRB
Write "H" pulse width	t_{WRHW8}	-	45	-	ns	WRB
Data setup timing	t_{DSS}	-	30	-	ns	DB[17:0]
Data hold timing	t_{DH8}	-	10	-	ns	DB[17:0]

notice) All the timing reference is 10% and 90% of VDD.

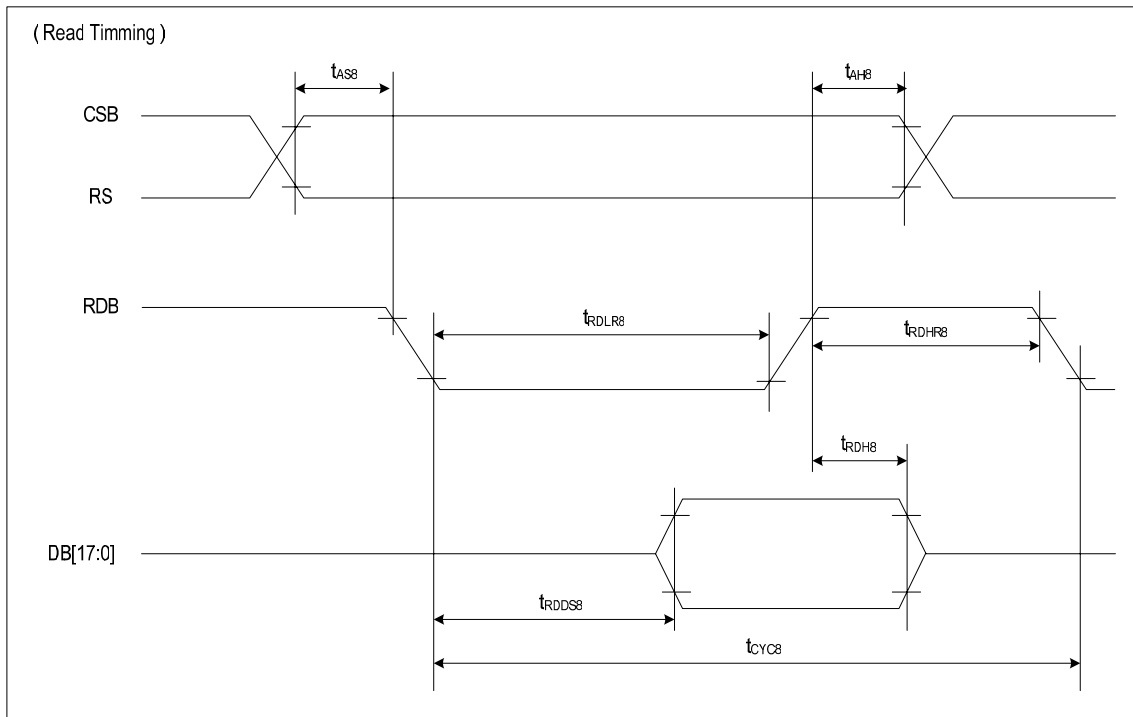

(VDD = 2.8V, Ta = 25°C)

ITEM	SYMBOL	CONDITION	MIN	MAX	UNIT	PORT
Address hold timing	t_{AH8}	-	5	-	ns	CSB
Address setup timing	t_{AS8}	-	5	-	ns	RS
System cycle timing	t_{CYC8}	-	200	-	ns	
Read "L" pulse width	t_{RDLR8}	-	90	-	ns	RDB
Read "H" pulse width	t_{RDHR8}	-	90	-	ns	RDB
Read data output delay time	t_{RDH8}	CL = 15 pF	-	60	ns	DB[17:0]
Data hold timing	t_{RDDS8}		0		ns	DB[17:0]

notice) All the timing reference is 10% and 90% of VDD.

4-2) System BUS Read/Write Timing (68 series CPU interface)

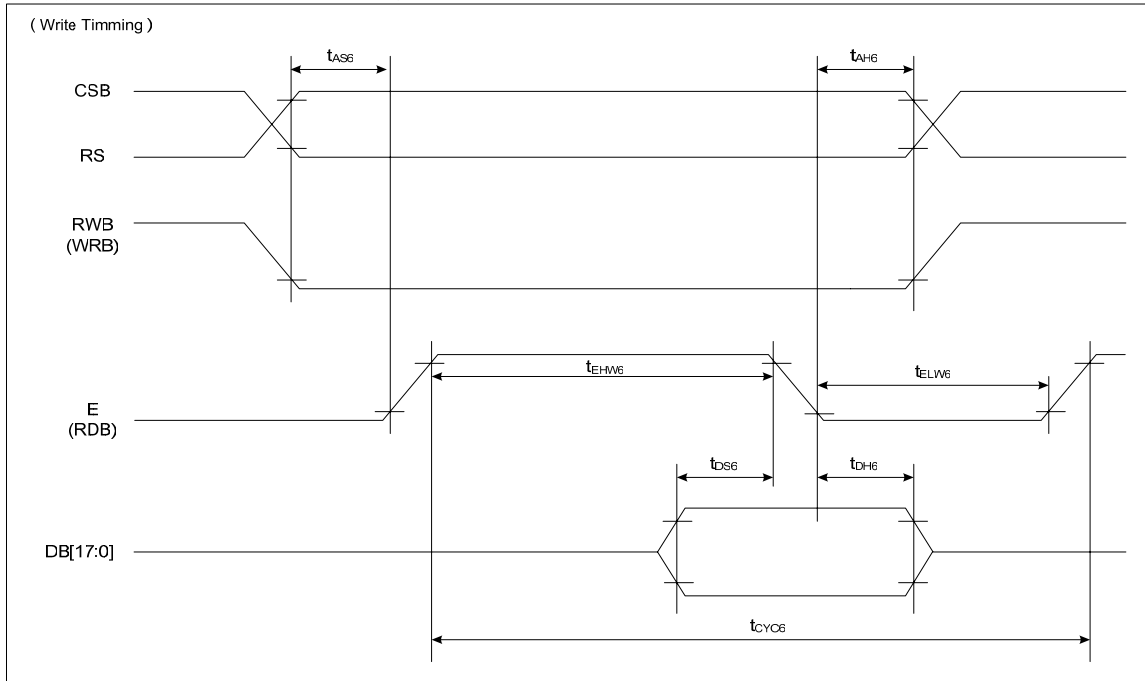

(VDD = 2.8V, Ta = 25°C)

ITEM	SYMBOL	CONDITION	MIN	MAX	UNIT	PORT
Address hold timing	t_{AH6}	-	5	-	ns	CSB
Address setup timing	t_{AS6}	-	5	-	ns	RS
System cycle timing	t_{CYC6}	-	100	-	ns	
Write "L" pulse width	t_{ELW6}	-	45	-	ns	E
Write "H" pulse width	t_{EHW6}	-	45	-	ns	
Data setup timing	t_{DS6}	-	40	-	ns	DB[17:0]
Data hold timing	t_{DH6}	-	10	-	ns	

notice) All the timing reference is 10% and 90% of VDD.

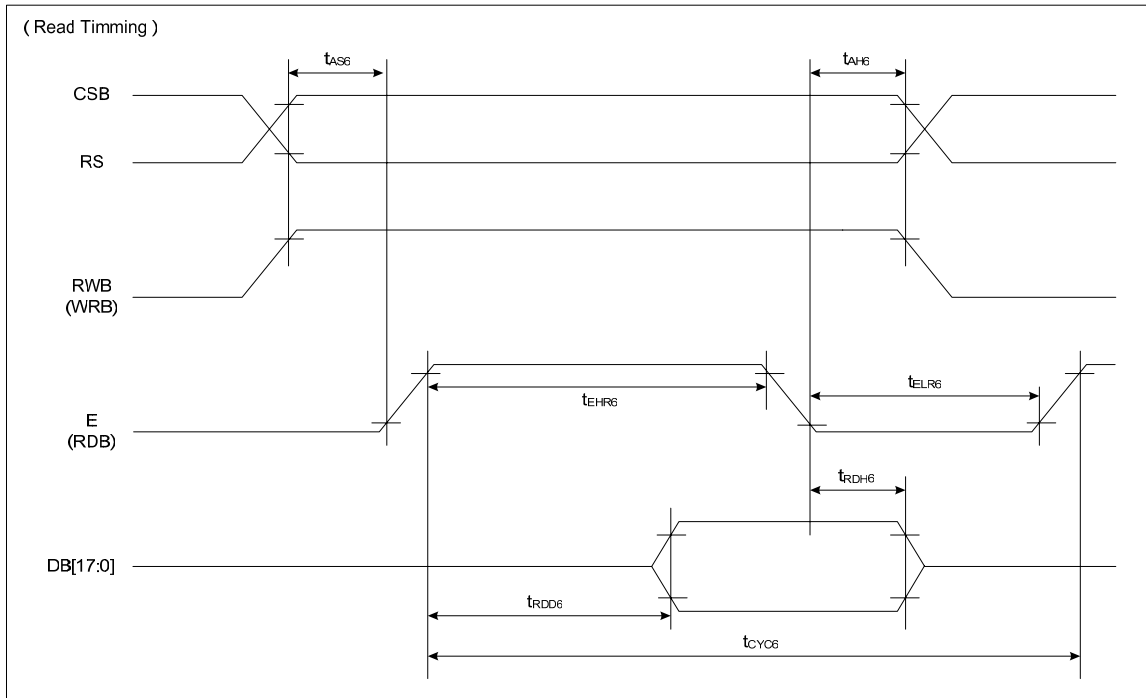

(VDD = 2.8V, Ta = 25°C)

ITEM	SYMBOL	CONDITION	MIN	MAX	UNIT	PORT
Address hold timing	t _{AH6}	-	10	-	ns	CSB
Address setup timing	t _{AS6}	-	10	-	ns	RS
System cycle timing	t _{CYC6}	-	200	-	ns	E
Read "L" pulse width	t _{ELR6}	-	90	-	ns	E
Read "H" pulse width	t _{EHR6}	-	90	-	ns	E
Read data output delay time	t _{RDD6}	CL = 15 pF	0	70	ns	DB[17:0]
Data hold timing	t _{RDH6}	CL = 15 pF	0	70	ns	DB[17:0]

notice) All the timing reference is 10% and 90% of VDD.

4-3) Serial Interface Timing

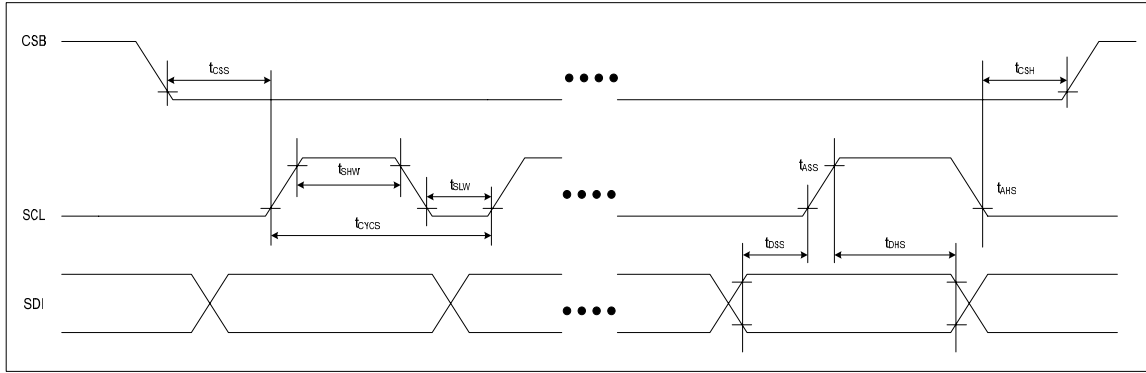

(VDD = 2.8V, Ta = 25°C)

ITEM	SYMBOL	CONDITION	MIN	MAX	UNIT	PORT
Serial clock cycle	t_{cycs}		60		ns	
SCL "H" pulse width	t_{shw}	-	25	-	ns	SCL
SCL "L" pulse width	t_{slw}		25		ns	
Data setup timing	t_{dss}	-	25	-	ns	SDI
Data hold timing	t_{dhs}		25		ns	
CSB-SCL timing	t_{css}	-	25	-	ns	CSB
CSB-hold timing	t_{csh}		25		ns	

notice) All the timing reference is 10% and 90% of VDD.

4-4) External Clock Input Timing

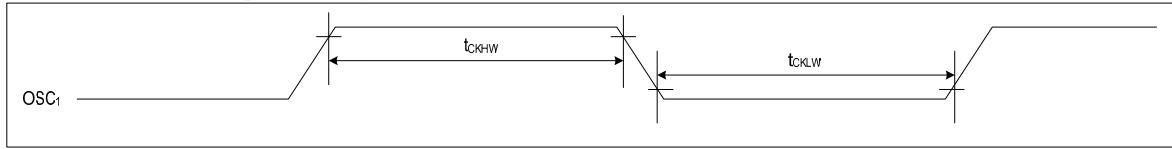

(VDD = 2.8V, Ta = 25°C)

ITEM	SYMBOL	CONDITION	MIN	MAX	UNIT	PORT
Osc1 "H" pulse width (1)	tckHW1		TBD	TBD	us	OSC1
Osc1 "L" pulse width (1)	tckLW1		TBD	TBD	us	
Osc1 "H" pulse width (2)	tckHW2		TBD	TBD	us	OSC1
Osc1 "L" pulse width (2)	tckLW2		TBD	TBD	us	

4-5) Reset Input Timing

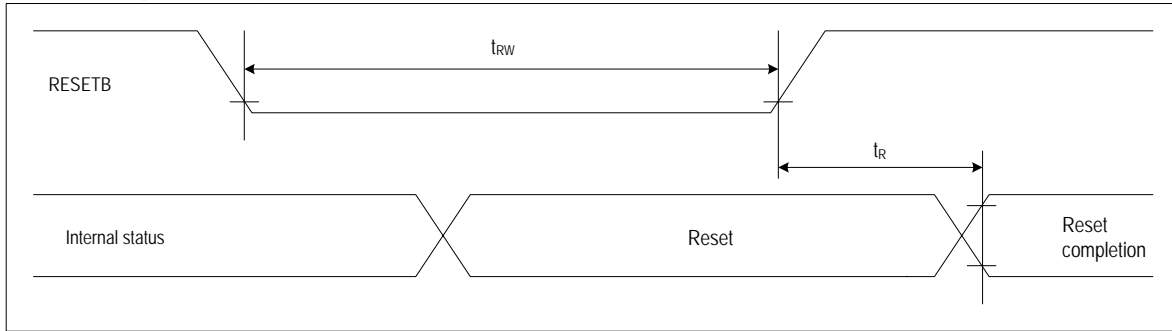

(VDD = 2.8V, Ta = 25°C)

ITEM	SYMBOL	CONDITION	MIN	MAX	UNIT	PORT
Reset time	tr			1.5	us	
RESETB "L" pulse width	trw		5		us	RESETB

7. Application Example

1) Connection With CPU

1-1) 80 Series CPU Interface(18-bit bus)

=> PS = "1", CPU = "0", DFM[1:0] = "00"

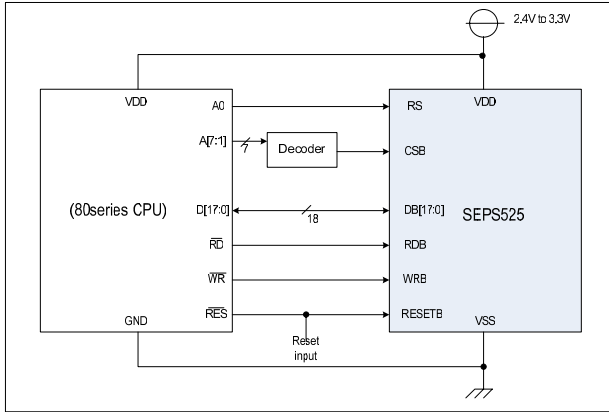

1-2) 68 Series CPU Interface(18-bit bus)

=> PS = "1", CPU = "1", DFM[1:0] = "00"

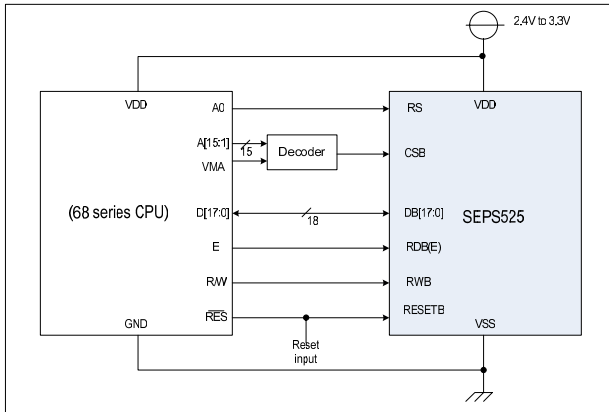

1-3) CPU Connection With Serial Interface

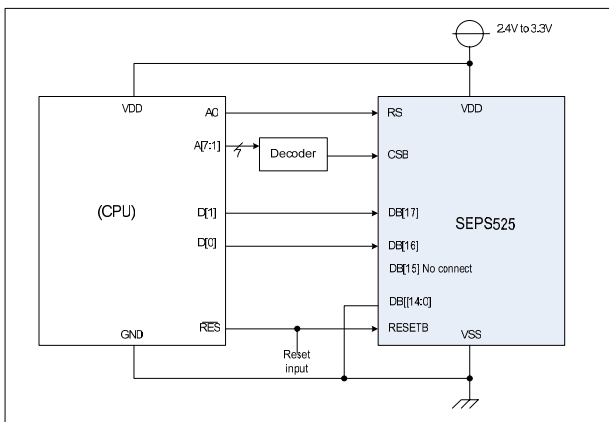

Revision History

Rev. #	Contents	page	Name	Date
0.0	Draft		YK Kim/ A Ahn	2005. 12. 07
0.20	Address 04h, 15h Changed	P20,24	YK Kim/ A Ahn	2006. 04. 14