



EVERBOUQUET INTERNATIONAL CO., LTD.

WE CATCH THE
BEST TECH. FOREVER

PART NO. : MG12064B-SERIES

FOR MESSRS. : _____

CONTENTS

<i>NO.</i>	<i>ITEM</i>	<i>PAGE</i>
1.	COVER	1
2.	RECORD OF REVISION	2
3.	GENERAL SPECIFICATION	3
4.	MECHANICAL DATA	4
5.	ABSOLUTE MAXIMUM RATINGS	5
6.	ELECTRICAL CHARACTERISTICS	6
7.	OPTICAL CHARACTERISTICS	7
8.	OUTLINE DIMENSION AND INTERNAL PIN CONNECTION	8~9
9.	BLOCK DIAGRAM	10
10.	POWER SUPPLY	10~11

ACCEPTED BY : _____

PROPOSED BY : _____



RECORD OF REVISION

DATE	PAGE	SUMMARY

3. General specifications

3.1 General specifications

PLEASE REFER TO:

“CUSTOMER ACCEPTANCE STANDARD SPECIFICATIONS (MS-10-61202)”.

3.2 This individual specification is prior to general specifications

3.3 NUMBERING SYSTEM

MG12064B	-	<table border="1"><tr><td>S</td><td>Y</td><td>M</td><td>L</td><td>W</td><td>U</td></tr></table>	S	Y	M	L	W	U
S	Y	M	L	W	U			
		(1)	(2)	(3)	(4)	(5)	(6)	

(1).LCD TYPE :

“S” : STN TYPE

“F” : FSTN TYPE

(2).LCD COLOR :

“Y” : YELLOW-GREEN “B” : BLUE(STN/NEGATIVE)/BLACK(FSTN/NEGATIVE)

“G” : GRAY “W” : WHITE(FSTN/POSITIVE)

(3).LCD POLARIZE TYPE

“nil” : TRANSFLECTIVE

“M” : TRANSMISSIVE

(4).BACKLIGHT TYPE :

“E” : EL BACKLIGHT

“L” : LED BACKLIGHT

“R” : REFLECTIVE

(5).BACKLIGHT COLOR :

LED TYPE :

“nil” : YELLOW-GREEN “A” : AMBER “B” : BLUE

“G” : PURE-GREEN “O” : ORANGE “R” : RED

“W” : WHITE

EL TYPE :

“nil” : WHITE “B” : BLUE-GREEN

(6).VIEWING DIRECTION :

“nil” : 6 O’CLOCK “3” : 3 O’CLOCK

“U” : 12 O’CLOCK “9” : 9 O’CLOCK

4. Mechanical data

- (1) NUMBER OF DOTS-----128 W * 64 H DOTS
- (2) MODULE SIZE -----93.0 W * 70.0 H * "C" T (Max) mm
- (3) EFFECTIVE AREA -----71.0 W * 39.0 H mm
- (4) ACTIVE AREA -----66.52 W * 33.24 H mm
- (5) DOT SIZE-----0.48 W * 0.48 H mm
- (6) DOT PITCH-----0.52 W * 0.52 H mm

NOTE : The dimension of "C" , please refer to Outline dimension on PAGE 8/11

5. Absolute maximum ratings

5.1 Electrical absolute maximum ratings

<i>I T E M</i>	<i>SYMBOL</i>	<i>MIN.</i>	<i>MAX.</i>	<i>UNIT</i>	<i>COMMENT</i>
POWER SUPPLY FOR LOGIC	V _{DD} -V _{SS}	0	6.0	V	-----
INPUT VOLTAGE	V _I	V _{SS}	V _{DD}	V	-----
STATIC ELECTRICITY	-----	-----	100	V	NOTE (1)
POWER SUPPLY FOR EL BACKLIGHT	V _{EL}	-----	AC200	V _{rms}	f _{EL} =1.0KHz 60 SEC.MAX
	f _{EL}	-----	2.0	KHz	AC115 V _{rms} 60 SEC.MAX
POWER SUPPLY FOR LED	V _{LED}	-----	NOTE(2)	V	-----

NOTE (1): ELECTRO-STATIC DISCHARGE RESISTANCE IS TESTED BY CHARGING A 200PF CAPACITOR AND DISCHARGING IT BY CONTACT WITH A INTERFACE CONNECTOR PIN.

NOTE (2):

<i>SYMBOL</i>	<i>V_{LED} MAX.</i>	<i>LED TYPE</i>
V _{LED}	6.0V	YELLOW-GREEN,AMBER,ORANGE,RED
	5.0V	WHITE, BLUE, PURE-GREEN

5.2 Environmental absolute maximum ratings

<i>I T E M</i>	<i>OPERATING</i>		<i>STORAGE</i>		<i>COMMENT</i>
	<i>MIN.</i>	<i>MAX.</i>	<i>MIN.</i>	<i>MAX.</i>	
AMBIENT TEMPERATURE	-20	70	-20	70	-----
HUMIDITY	NOTE (3)		NOTE (3)		NO CONDENSATION
VIBRATION NOTE (4)	-----	0.5G	-----	2G	10 300HZ XYZ DIRECTIONS 1 Hr EACH
SHOCK NOTE (4)	-----	3G	-----	50G	10 msec XYZ DIRECTIONS 1 TIME EACH
CORROSIVE GAS	NOT ACCEPTABLE		NOT ACCEPTABLE		-----

NOTE (3): Ta 50 : 90% RH MAX.

Ta > 50 : ABSOLUTE HUMIDITY MUST BE LOWER THAN THE HUMIDITY OF 90% RH AT 50 . (80%RH AT 60)

NOTE (4): 1G = 9.8 m/s²

6. Electrical characteristics

$T_a = 25$

$V_{DD} = 5.0 \pm 0.25 V$

<i>I T E M</i>	<i>SYMBOL</i>	<i>CONDITION</i>	<i>MIN.</i>	<i>TYP.</i>	<i>MAX.</i>	<i>UNIT</i>	
POWER SUPPLY VOLTAGE FOR CIRCUIT	$V_{DD}-V_{SS}$	-----	4.75	5.0	5.25	V	
INPUT VOLTAGE NOTE (2)	V_{IH}	H LEVEL	$0.7V_{DD}$	-----	V_{DD}	V	
	V_{IL}	L LEVEL	V_{SS}	-----	$0.3V_{DD}$	V	
OUTPUT VOLTAGE NOTE (1)	V_{OH}	$I_{OH} = -0.4 \text{ mA}$	$V_{DD}-0.4$	-----	-----	V	
	V_{OL}	$I_{OL} = 0.4 \text{ mA}$	-----	-----	0.4	V	
POWER SUPPLY CURRENT, NOTE (3)	I_{DD}	$V_{DD}-V_{SS} = 5.0V$	-----	5.0	8.0	mA	
RECOMMENDED LCD DRIVING VOLTAGE, NOTE(4)	$V_{DD}-V_O$	STN/ FSTN DUTY =1/64 =10° NOTE(5)	$T_a = -20^\circ C$	-----	8.9	-----	V
			$T_a = 25^\circ C$	-----	8.5	-----	V
			$T_a = 70^\circ C$	-----	8.1	-----	V
POWER SUPPLY CURRENT FOR EL BACKLIGHT	I_{EL}	$V_{EL} = 115V_{rms}$ $f_{EL} = 400Hz$	-----	5.0	-----	mArms	
POWER SUPPLY CURRENT FOR LED	I_{LED}	NOTE(6)	-----	NOTE(6)	NOTE(6)	mA	

NOTE(1): APPLIED TO TERMINALS DB0~DB7

(2): APPLIED TO TERMINALS $\overline{D/I}$, $\overline{R/W}$, E, DB0~DB7, CS1, CS2, \overline{RST}

(3): THE DISPLAY PATTERN IS ALL "ON", OR ALL "OFF"

(4): RECOMMENDED LCD DRIVING VOLTAGE MAY FLUCTUATE ABOUT $\pm 0.5V$ BY EACH MODULE.

(5): $= 0^\circ$: VIEWING DIRECTION AT 6 O'CLOCK

$= 180^\circ$: VIEWING DIRECTION AT 12 O'CLOCK

(6): LED CURRENT FOR DIFFERENT LED BACKLIGHT TYPE

<i>LED B.L TYPE</i>	<i>CONDITION</i>	<i>I_{LED}</i>				<i>LED COLOR</i>
		<i>MIN.</i>	<i>TYP.</i>	<i>MAX.</i>	<i>UNIT.</i>	
LED B.L (ARRAY)	$V_{LED} = 5.0V$	-----	250	375	mA	YELLOW-GREEN, AMBER, ORANGE, RED
LED B.L (EDGE)	$V_{LED} = 4.0V$	-----	75	100	mA	BLUE, WHITE, PURE-GREEN

7. Optical characteristics

STN TYPE LCD

 $T_a = 25$
 $V_{DD}-V_O = 8.5V$

<i>I T E M</i>	<i>SYMBOL</i>	<i>CONDITION</i>	<i>MIN.</i>	<i>TYP.</i>	<i>MAX.</i>	<i>UNIT</i>	<i>NOTE</i>
VIEWING ANGLE	2- 1	K = 2.0 NOTE(1)	30	40	----	deg.	NOTE(2)
CONTRAST RATIO	K	= 10° NOTE(1)	3.0	4.0	----	----	NOTE(2)
RESPONSE TIME	tr (rise)	= 10° NOTE(1)	----	200	350	ms	NOTE(2)
	tf (fall)	= 10° NOTE(1)	----	300	400	ms	NOTE(2)

FSTN, STN BLUE TYPE LCD

 $T_a = 25$
 $V_{DD}-V_O = 8.5V$

<i>I T E M</i>	<i>SYMBOL</i>	<i>CONDITION</i>	<i>MIN.</i>	<i>TYP.</i>	<i>MAX.</i>	<i>UNIT</i>	<i>NOTE</i>
VIEWING ANGLE	2- 1	K = 2.0 NOTE(1)	30	40	----	deg.	NOTE(2)
CONTRAST RATIO	K	= 10° NOTE(1)	4.0	5.0	----	----	NOTE(2)
RESPONSE TIME	tr (rise)	= 10° NOTE(1)	----	200	350	ms	NOTE(2)
	tf (fall)	= 10° NOTE(1)	----	300	400	ms	NOTE(2)

Brightness for LED backlight

<i>SYMBOL</i>	<i>CONDITION</i>	<i>MIN.</i>	<i>TYP.</i>	<i>MAX.</i>	<i>UNIT</i>	<i>LED TYPE</i>	<i>NOTE</i>
B	= 0° = 0°	4.0	----	----	cd/m ²	EL BACKLIGHT	NOTE(2) NOTE(3)
		5.0	----	----		YELLOW-GREEN, RED AMBER, ORANGE	
		6.0	----	----		BLUE, WHITE, PURE-GREEN	

NOTE (1): = 0° : VIEWING DIRECTION AT 6 O'CLOCK

= 180° : VIEWING DIRECTION AT 12 O'CLOCK

NOTE (2): SEE CUSTOMER ACCEPTANCE STANDARD SPECIFICATION FOR DEFINITION OF OPTICAL CHARACTERISTICS.

NOTE (3): UNDER NORMAL TEMPERATURE AND HUMIDITY IN A DARK ROOM.

8. Outline dimension

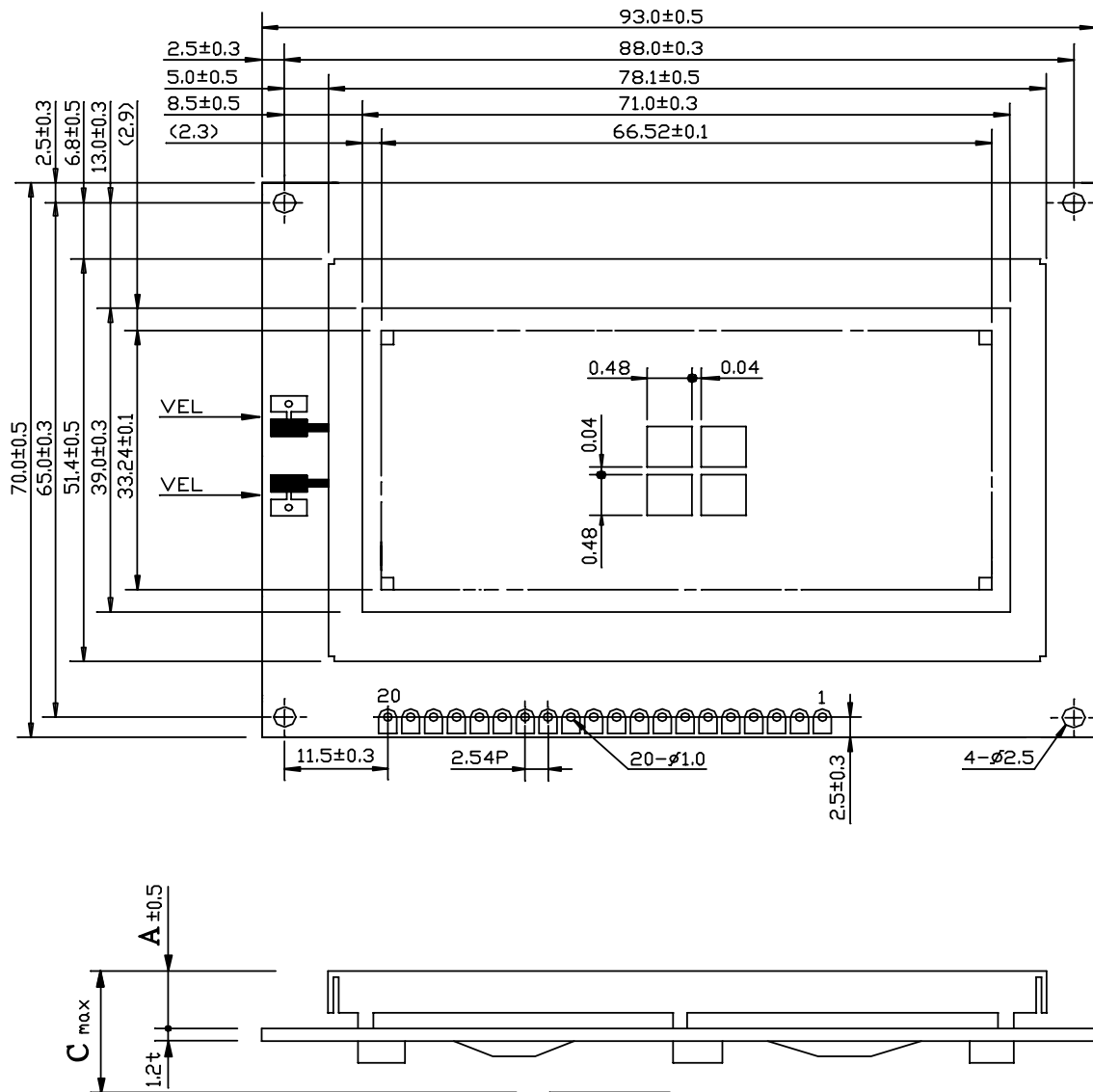

TYPE	A	C
LED B.L	9.0	15.0
EL & NO B.L	5.0	10.0

NOTE :

1.UNIT : mm

2.SCALE : NTS

Interface pin connection

PIN NO.	SYMBOL	FUNCTION
1	V _{SS}	GROUND
2	V _{DD}	POWER SUPPLY FOR LOGIC
3	V _O	OPERATING VOLTAGE FOR LCD DRIVING
4	D/ \bar{I}	H: DATA INPUT L: INSTRUCTION CODE INPUT
5	$\overline{R/W}$	H: DATA READ (LCD MODULE MPU) L: DATA WRITE (LCD MODULE MPU)
6	E	ENABLE SIGNAL
7	DB0	DATA INPUT/OUTPUT (LSB)
8	DB1	DATA INPUT/OUTPUT
9	DB2	DATA INPUT/OUTPUT
10	DB3	DATA INPUT/OUTPUT
11	DB4	DATA INPUT/OUTPUT
12	DB5	DATA INPUT/OUTPUT
13	DB6	DATA INPUT/OUTPUT
14	DB7	DATA INPUT/OUTPUT (MSB)
15	CS1	H: CHIP SELECTION FOR IC1
16	CS2	H: CHIP SELECTION FOR IC2
17	\overline{RST}	L: RESET
18	V _{OUT}	POWER SUPPLY FOR LCD DRIVING
19	A(+)	POWER SUPPLY FOR LED (+)
20	K(-)	POWER SUPPLY FOR LED (-)

9. Block diagram

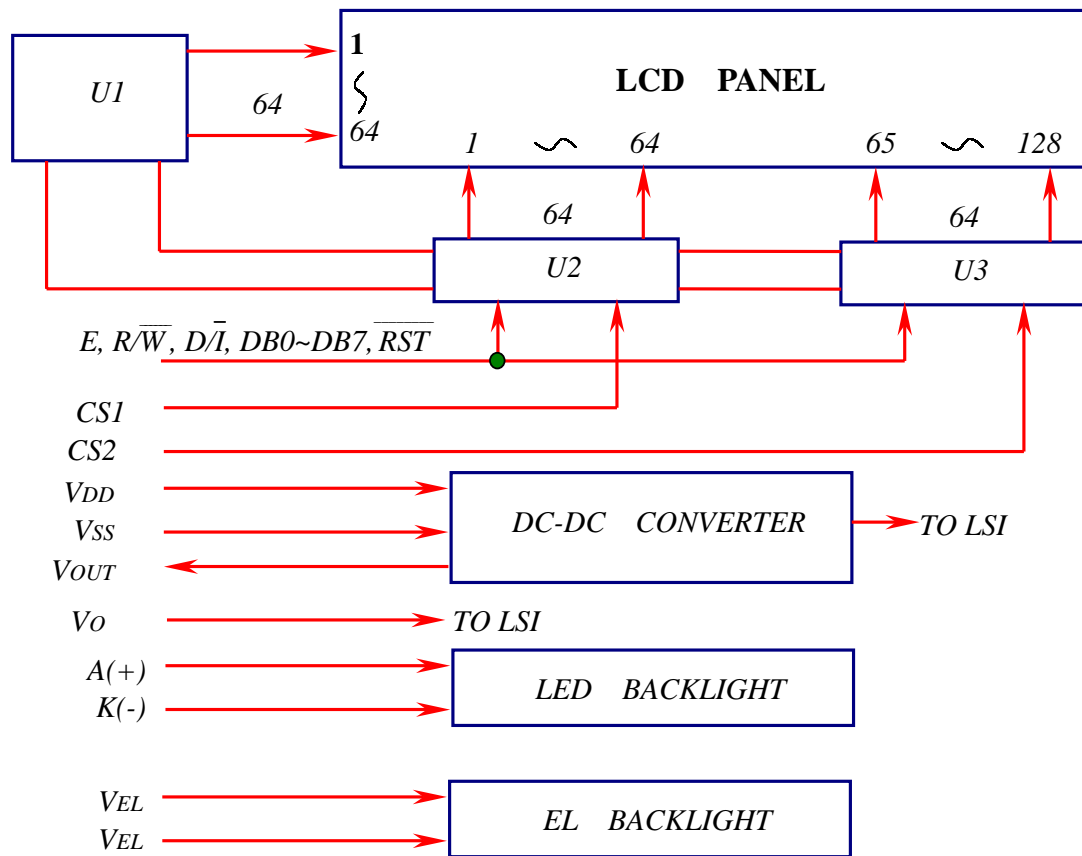

10. Power supply for LCM

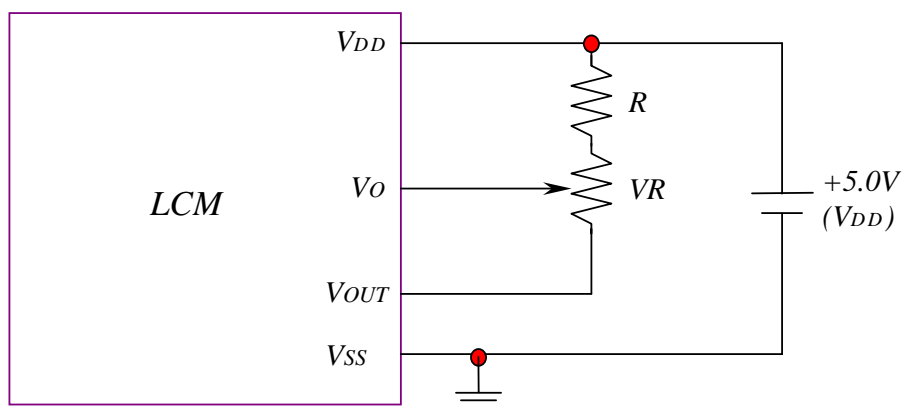

RECOMMENDED RESISTOR R: $V_{DD} - V_o \quad 1.5V$

$V_{DD} - V_o$: LCD DRIVING VOLTAGE

V_R : 10K ~20K

10.1 Power supply for backlight

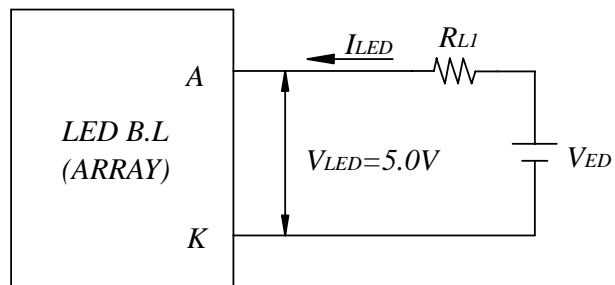
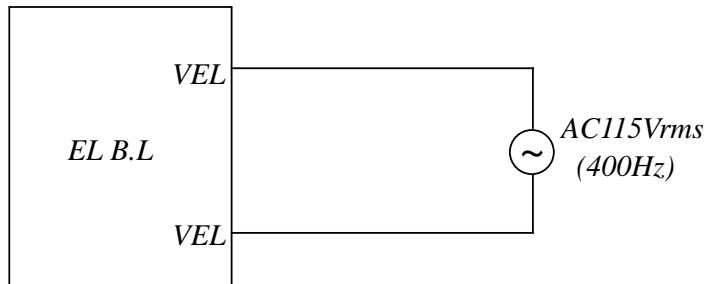

$$RL1 = (V_{ED} - V_{LED}) / I_{LED}, RL1 = 1W, I_{LED} = 375.0 \text{ mA (max)}$$

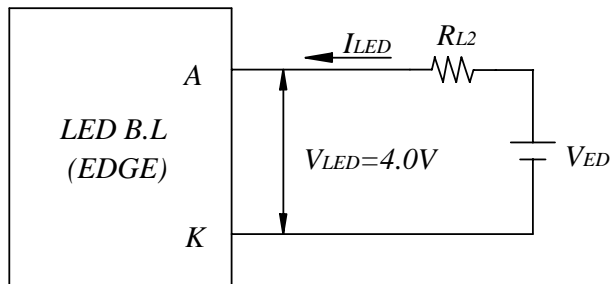

$$RL2 = (V_{ED} - V_{LED}) / I_{LED}, RL2 = 1W, I_{LED} = 100.0 \text{ mA (max)}$$