

LQ106K1LA05 LCD Module

Product Specification

July 2007

1280 × 768 Wide Aspect LCD Module featuring
LVDS interface, 280 nits brightness with 350:1
contrast. Full Specifications Listing.

APREPARED BY : DATE	SHARP	SPEC No. LD-19726B
APPROVED BY : DATE		FILE No.
		ISSUE : Jul. 31. 2007
		PAGE : 21 pages
	MOBILE LIQUID CRYSTAL DISPLAY GROUP SHARP CORPORATION	APPLICABLE GROUP MOBILE LIQUID CRYSTAL DISPLAY GROUP
	SPECIFICATION	

DEVICE SPECIFICATION FOR
TFT-LCD Module
 MODEL No.
LQ106K1LA05

CUSTOMER'S APPROVAL

DATE _____

BY _____

PRESENTED

BY *K. Shiono*

K. SHIONO
 Department General Manager
 Engineering Dept.
 MOBILE LCD DIVISION III
 MOBILE LIQUID CRYSTAL DISPLAY GROUP
 SHARP CORPORATION

These specification sheets are the proprietary product of SHARP CORPORATION("SHARP) and include materials protected under copyright of SHARP. Do not reproduce or cause any third party to reproduce them in any form or by any means, electronic or mechanical, for any purpose, in whole or in part, without the express written permission of SHARP.

In case of using the device for applications such as control and safety equipment for transportation(aircraft, trains, automobiles, etc.), rescue and security equipment and various safety related equipment which require higher reliability and safety, take into consideration that appropriate measures such as fail-safe functions and redundant system design should be taken.

Do not use the device for equipment that requires an extreme level of reliability, such as aerospace applications, telecommunication equipment(trunk lines), nuclear power control equipment and medical or other equipment for life support.

SHARP assumes no responsibility for any damage resulting from the use of the device which does not comply with the instructions and the precautions specified in these specification sheets.

This specification sheet is to guarantee the quality of the LCD module itself, only Should you need to evaluate and confirm the performance of the module, please do so when the LCD module is assembled into your finished product.

If any problem occurs in relation to the description of this specification, it shall be resolved through discussion with spirit of cooperation.

Contact and consult with a SHARP sales representative for any questions about this device.

Table of contents

1. Application	3
2. Overview	3
3. Mechanical Specifications	3
4. Input Terminals	4
4-1. TFT-LCD panel driving	4
4-2. LVDS interface block diagram	5
5. Absolute Maximum Ratings	6
6. Electrical Characteristics	6
6-1. TFT-LCD panel driving	6
6-2. Backlight driving	8
6-3. LVDS input specification	9
6-3-1. AC characteristics	9
6-3-2. LVDS data	9
7. Timing Characteristics of Input Signals	10
7-1. Timing characteristics	10
7-2. Display position	11
7-3. Input data signals and display position on the screen	11
8. Input Signals, Basic Display Colors and Gray Scale of Each Color	12
9. Optical Characteristics	13
10. Display Quality	14
11. Handling Precautions	15
12. Packing Form	15
13. Reliability Test Items	16
14. Label	17
15. RoHS Regulations	17
Fig1 Packing Form	18
Fig.2 Outline Dimensions	19

1. Application

This technical literature applies to a color TFT-LCD module, LQ106K1LA05.

2. Overview

This module is a color active matrix LCD module incorporating amorphous silicon TFT (Thin Film Transistor). It is composed of a color TFT-LCD panel, driver ICs, control circuit and power supply circuit and a backlight unit. Graphics and texts can be displayed on a 1280×3×768 dots panel with 262,144 colors by using LVDS (Low Voltage Differential Signaling) to interface and supplying +3.3V DC supply voltage for TFT-LCD panel driving and supply voltage for backlight.

In this TFT-LCD panel , low reflection / color filters of excellent color performance and backlights of high brightness are incorporated to realize brighter and clearer pictures, making this model optimum for use in multi-media applications.

Optimum viewing direction is 6 o'clock.

White-LED Backlight-driving DC/DC converter is not built in this module.

3. Mechanical Specifications

Parameter	Specifications	Unit
Display size	27 (10.6") Diagonal	cm
Active area	230.4(H)×138.2 (V)	mm
Pixel format	1280 (H)×768 (V)	pixel
	(1 pixel = R+G+B dots)	
Aspect ratio	15 : 9	
Pixel pitch	0.180 (H)×0.180 (V)	mm
Pixel configuration	R,G,B vertical stripe	
Display mode	Normally white	
Surface treatment	Glare and hard-coating 2H Low reflection	

Parameter		Min.	Typ.	Max.	Unit
Unit outline dimensions [Note 1]	Width	250.1	250.6	251.1	mm
	Height	151.5	152.0	152.5	mm
	Depth	-	-	5.0	mm
Mass		-	175	190	g

[Note 1] Excluding the projection part.

Outline dimensions is shown in Fig.2

4. Input Terminals

4-1. TFT-LCD panel driving

CN1 (LVDS signals and +3.3V DC power supply)

Pin No.	Symbol	Function	Remark
1	V _{CC}	+3.3V power supply	
2	V _{CC}	+3.3V power supply	
3	GND		
4	GND		
5	RxIN0-	Receiver signal of LVDS CH0 (-)	[Note 1]
6	RxIN0+	Receiver signal of LVDS CH0 (+)	[Note 1]
7	RxIN1-	Receiver signal of LVDS CH1 (-)	[Note 1]
8	RxIN1+	Receiver signal of LVDS CH1 (+)	[Note 1]
9	RxIN2-	Receiver signal of LVDS CH2 (-)	[Note 1]
10	RxIN2+	Receiver signal of LVDS CH2 (+)	[Note 1]
11	CK IN-	Receiver signal of LVDS CLK (-)	[Note 1]
12	CK IN+	Receiver signal of LVDS CLK (+)	[Note 1]
13	GND		
14	LED_L1	White-LED B/L cathode 1	
15	LED_L2	White-LED B/L cathode 2	
16	LED_L3	White-LED B/L cathode 3	
17	LED_L4	White-LED B/L cathode 4	
18	LED_L5	White-LED B/L cathode 5	
19	N.C	N.C	[Note 3]
20	LED_H	White-LED B/L anode	

[Note 1] Relation between RxIN_i(i=0,1,2) and actual data is shown in following section (4-2)(7-2).

[Note 2] The shielding case is connected with signal GND.

[Note 3] Please use NC by OPEN. NC terminal is not connected with the internal circuit.

Using connector : DF19L-20P-1H (HIROSE)

Corresponding connector : DF19-20S-1C(HIROSE)

(Sharp is not responsible to its product quality, if the user applies a connector not corresponding to the above model.)

4-2 LVDS interface block diagram

LVDS receiver : Single LVDS interface contained in a control IC

Corresponding Transmitter : THC63LVDM63A (THINE) or equivalent

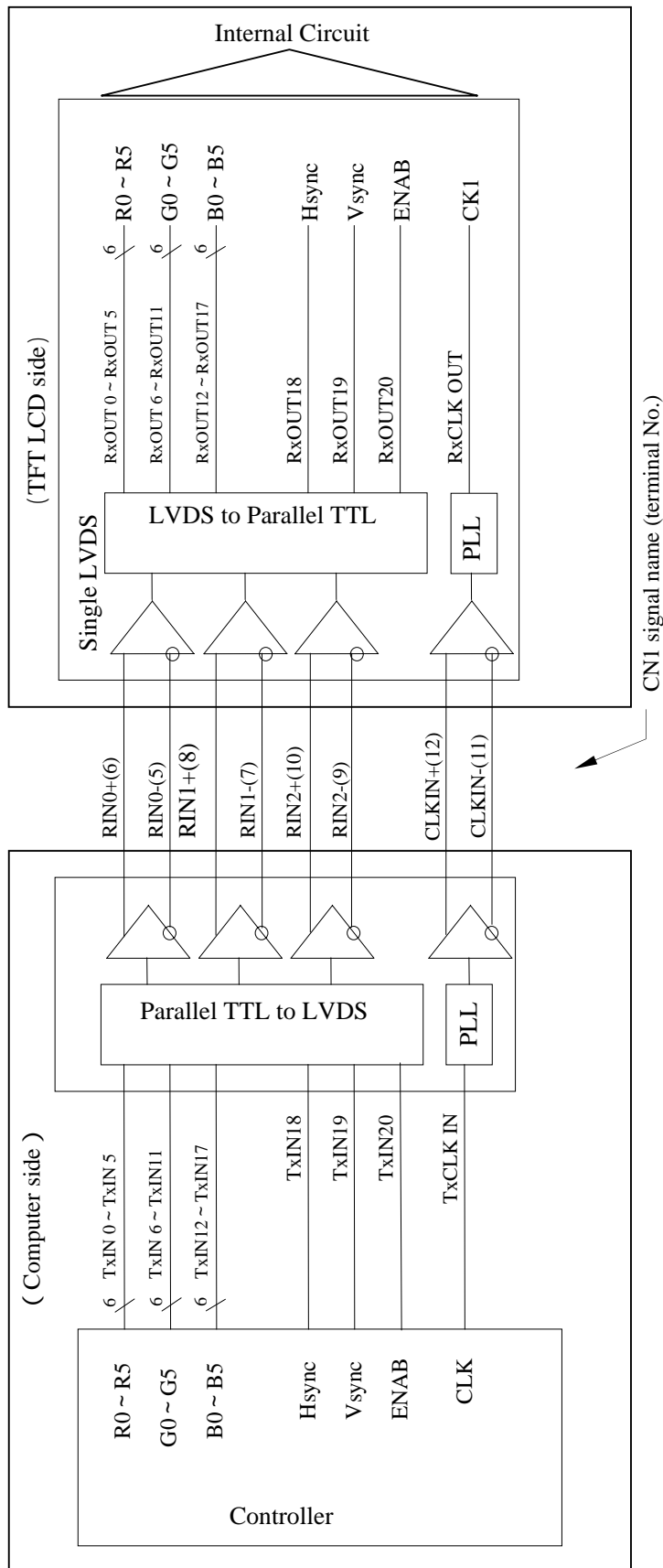

5. Absolute Maximum Ratings

Parameter	Symbol	Condition	Ratings		Unit	Remark
			Min.	Max.		
Input voltage	V_I	Ta=25	-0.3	V _{CC} +0.3	V	[Note 1]
+3.3V supply voltage	V _{CC}	Ta=25	0	+4.0	V	
LED forward current	I _{LED}	Ta=25	0	30	mA	
LED reverse voltage	V _{LED_R}	Ta=25	-	5	V	
Storage temperature	T _{stg}	-	-20	+60		[Note 2]
Operating temperature (Ambient)	Topa	-	0	+50		

[Note 1] LVDS signals

[Note 2] Humidity : 95%RH Max. at Ta +40 .

Maximum wet-bulb temperature at +39 or less at Ta>+40 .

No condensation.

6. Electrical Characteristics

6-1.TFT-LCD panel driving

Ta = +25

Parameter	Symbol	Min.	Typ.	Max.	Unit	Remark	
Supply voltage	V _{CC}	+3.0	+3.3	+3.6	V	[Note 2]	
Current dissipation	I _{CC}	-	310	500	mA	[Note 3]	
Permissible input ripple voltage	V _{RP}	-	-	100	mV _{P-P}	V _{CC} = +3.3V	
Input voltage range	V _I	0		2.4	V	LVDS signals	
Differential input threshold voltage	High	V _{TH}	-	-	+100	mV	V _{CM} = +1.2V
	Low	V _{TL}	-100	-	-	mV	[Note 1]
Input current (High)	I _{OH}	-	-	±10	μA	V _I = +2.4V V _{CC} = +3.6V	
Input current (Low)	I _{OL}	-	-	±10	μA	V _I = 0V V _{CC} = 3.6V	
Terminal resistor	R _T	-	100	-		Differential input	

[Note 1] V_{CM} : Common mode voltage of LVDS driver.

[Note 2]

On-off conditions for supply voltage

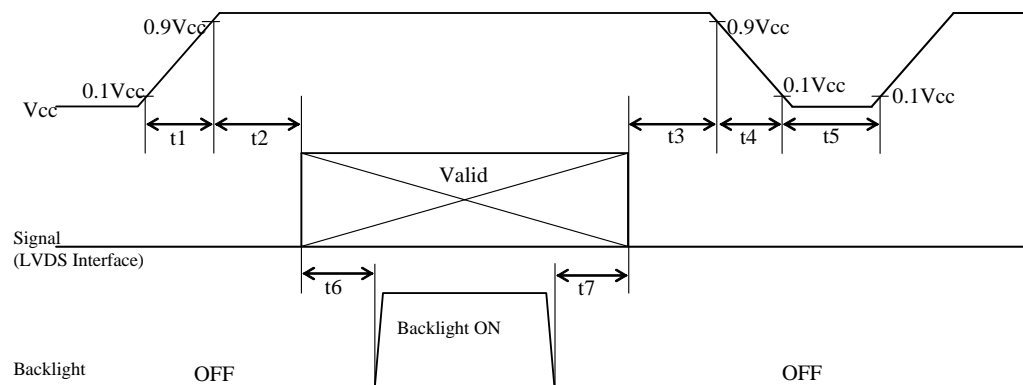

Symbol	Min.	Max.	Unit	Remark
t1	0	10	ms	
t2	0	100	ms	
t3	0	50	ms	
t4	0	400	ms	
t5	200	-	ms	
t6	180	-	ms	*1
t7	5	-	ms	*1

*1 : As for the power sequence for backlight, it is recommended to apply above mentioned input timing. If the backlight is lit on and off at a timing other than shown above, displaying image may get disturbed. This is due to variation of output signal from timing generator when LVDS signal is changed from on to off or vice versa, but has no harm to the module itself.

[Note] Do not keep the interface signal high-impedance or unusual signal when power is on.

Vcc-dip conditions

- 1) $2.5\text{ V} < V_{cc} < 3.0\text{ V}$

$t_d = 10\text{ ms}$

Under above condition, the display image should return to an appropriate figure after Vcc voltage recovers.

- 2) $V_{cc} < 2.5\text{ V}$

Vcc-dip conditions should also follow the On-off conditions for supply voltage

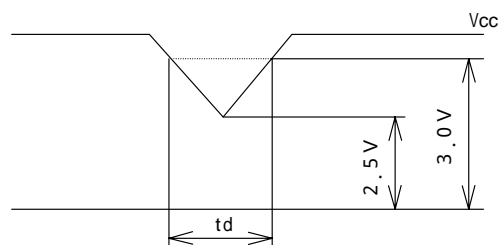

[Note 3] Typical current situation :

16-gray-bar pattern.

$V_{cc} = +3.3\text{ V}$, clock frequency 81MHz

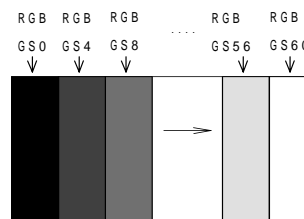

6-2. Backlight driving

The backlight system is edge-lighting type with 45 White-LED(White Light Emitting Diode).

The characteristics of White-LED are shown in the following table. (Ta=25 °C)

Parameter	Symbol	Min.	Typ.	Max.	Unit	Remark
LED voltage	V_L	-	28.8	31.5	V	
LED current range	V_L	2	17	17	mA	Value for one string
Number of circuit strings		-	5	-		[Note 1]
LED power consumption	W_L	-	2.45	-	W	[Note 2]
LED life time	L_L	10000	-	-	Hour	[Note 3]

[Note 1] The LED backlight is composed by 5 strings from which 9 LED is connected with the series.

The figure below shows the circuit chart of each string.

In each circuit, there is a ceramic capacitor for the electrostatic protection.

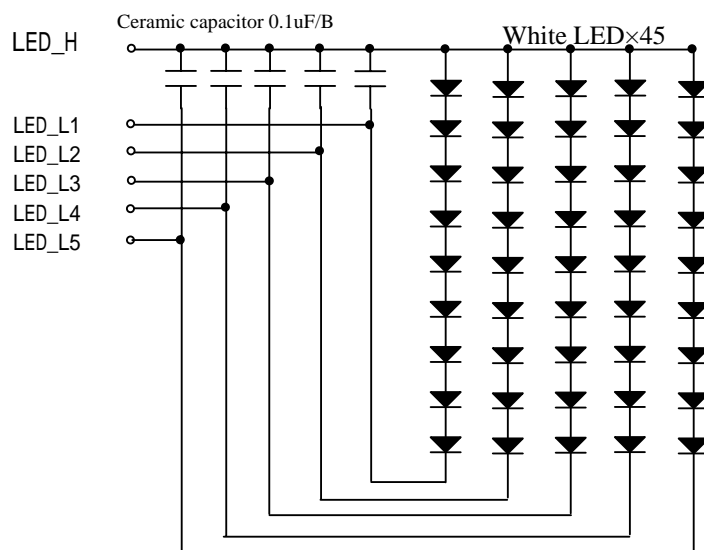

[Note 2] Calculated value for reference ($I_L \times V_L$)

[Note 3] LED life time is defined as the time when Brightness becomes 50 % of the original value.
under the condition of $T_a = 25$ and $I_f = 17$ mA, and continuous lighting.

6-3. LVDS input specification

6-3-1. AC characteristics

$V_{CC}=+3.0V \sim +3.6V$, $T_a = 0 \sim +50$

Parameter	Symbol	Min	Typ.	Max.	Unit
Input Data Position 0 (t _{RCIP} =15.38ns)	t _{RIP1}	-0.25	0.0	+0.25	ns
Input Data Position 1 (t _{RCIP} =15.38ns)	t _{RIP0}	t _{RCIP} /7-0.25	t _{RCIP} /7	t _{RCIP} /7+0.25	ns
Input Data Position 2 (t _{RCIP} =15.38ns)	t _{RIP6}	2 t _{RCIP} /7-0.25	2 t _{RCIP} /7	2 t _{RCIP} /7+0.25	ns
Input Data Position 3 (t _{RCIP} =15.38ns)	t _{RIP5}	3 t _{RCIP} /7-0.25	3 t _{RCIP} /7	3 t _{RCIP} /7+0.25	ns
Input Data Position 4 (t _{RCIP} =15.38ns)	t _{RIP4}	4 t _{RCIP} /7-0.25	4 t _{RCIP} /7	4 t _{RCIP} /7+0.25	ns
Input Data Position 5 (t _{RCIP} =15.38ns)	t _{RIP3}	5 t _{RCIP} /7-0.25	5 t _{RCIP} /7	5 t _{RCIP} /7+0.25	ns
Input Data Position 6 (t _{RCIP} =15.38ns)	t _{RIP2}	6 t _{RCIP} /7-0.25	6 t _{RCIP} /7	6 t _{RCIP} /7+0.25	ns
Phase Lock Loop Set	t _{RPLL}	-	-	10	ms
Input Clock Period	t _{RCIP}	11.8	12.3	14.3	ns

LVDS input timing

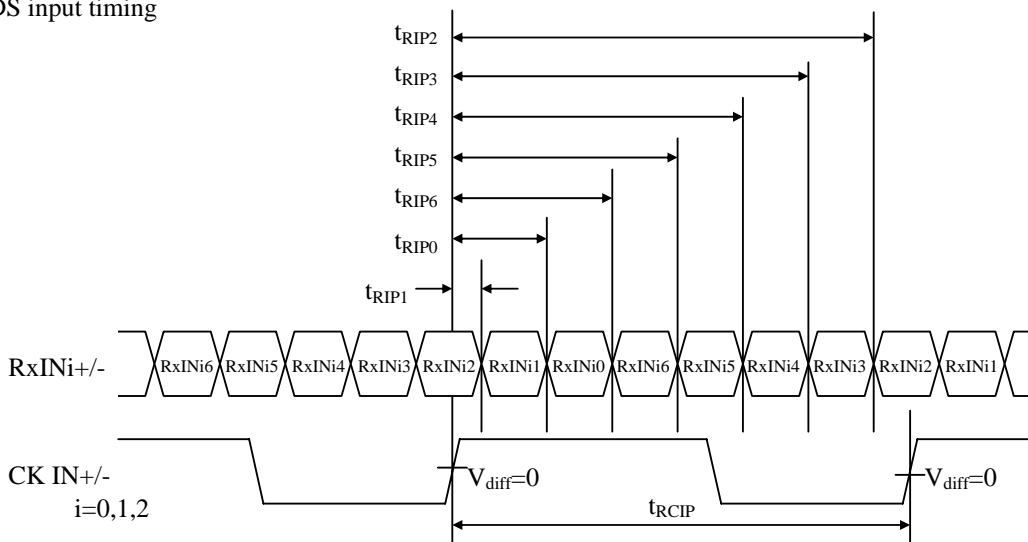

Note
 $V_{diff}=(R_{xINi+})-(R_{xINi-})$, $(CK IN+)-(CK IN-)$

LVDS phase lock loop set

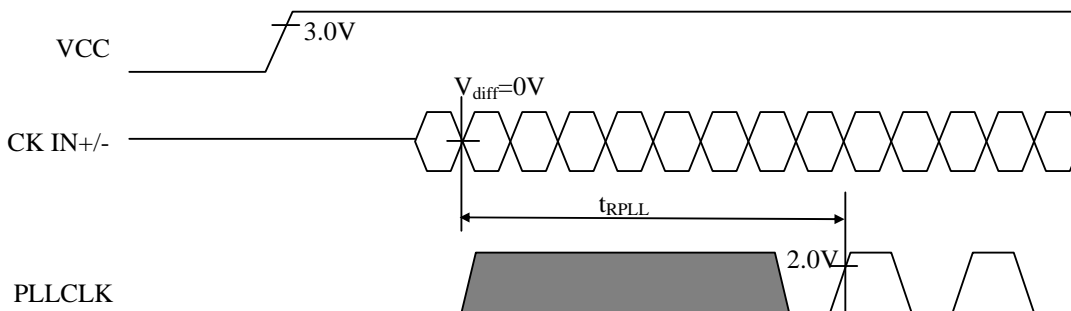

6-3-2.LVDS data

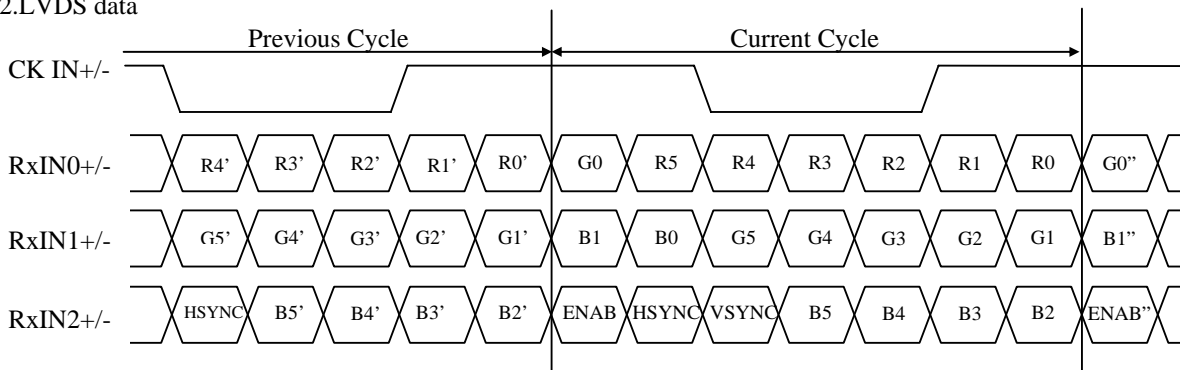

7. Timing Characteristics of Input Signals

7-1. Timing characteristics

(This is specified at digital outputs of LVDS driver.)

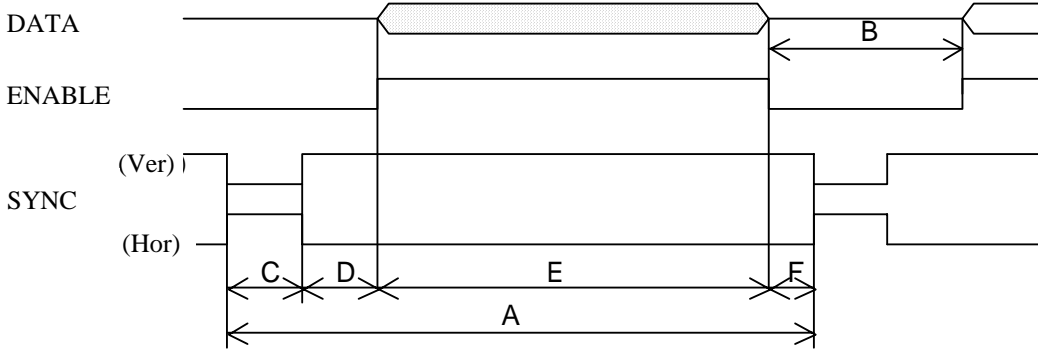

(Vertical)

Item (symbol)	Min.	Typ.	Max.	Unit	Remark
Vsync cycle (T_{VA})	-	16.7	-	ms	Negative
	800	802	900	line	
Blanking period (T_{VB})	32	34	132	line	
Sync pulse width (T_{VC})	2	6	-	line	
Sync pulse width + Back porch ($T_{VC}+T_{VD}$)	31	31	31	line	
Active display area (T_{VE})	768	768	768	line	
Front porch (T_{VF})	1	3	-	line	

(Horizontal)

Item (symbol)	Min.	Typ.	Max.	Unit	Remark
Hsync cycle (T_{HA})	20.26	20.8	24.70	us	Positive
	1652	1688	1856	clock	
Blanking period (T_{HB})	372	408	576	clock	
Sync pulse width (T_{HC})	2	112	-	clock	
Sync pulse width + Back porch ($T_{HC} + T_{HD}$)	4	360	$T_{HA}-1280$	clock	
Active display area (T_{HE})	1280	1280	1280	clock	

(Clock)

Item (symbol)	Min.	Typ.	Max.	Unit	Remark
Frequency	70	81	85	MHz	[Note1]

[Note1] In case of lower frequency, the deterioration of display quality, flicker etc., may be occurred.

(Hsync-Vsync Phase difference)

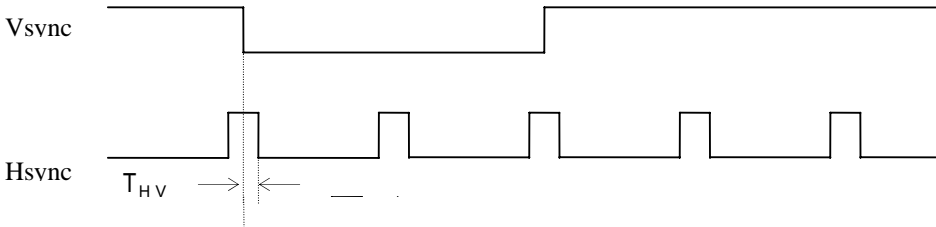

Item (symbol)	Min.	Typ.	Max.	Unit	Remark
Hsync-Vsync Phase difference (T_{HV})	1	-	$T_{HA}-T_{HC}$	clock	

(Hsync-ENAB Phase difference)

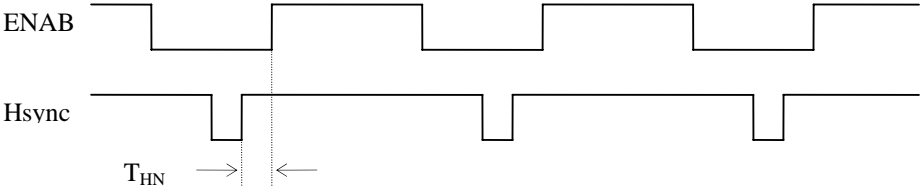

Item	Min.	Typ.	Max.	Unit	Remark
Hsync-ENAB Phase difference (T _{HN})	0	-	376	clock	

7-2. Display position

Item	Standards	Beginning	Ending	Unit	Remark
Horizontal	rising edge of ENAB	0	1280	clock	
	falling edge of Hsync	360	1640	clock	[Note 1]
Vertical	falling edge of Vsync	31	799	clock	

[Note 1] ENAB signal must be fixed to low.

[Note]

(Horizontal display direction)

When ENAB is fixed low, 360 clocks are counted from Hsync negative edge and data from after are available. If you need other timing, please use ENAB signal.

(Vertical display direction)

31 lines are counted from Vsync negative edge and data from next line are available.

(ENAB signal)

ENAB could not be used for the purpose of the vertical display start timing.

Caution

Image will not be displayed on the right position otherwise.

7-3. Input data signals and display position on the screen

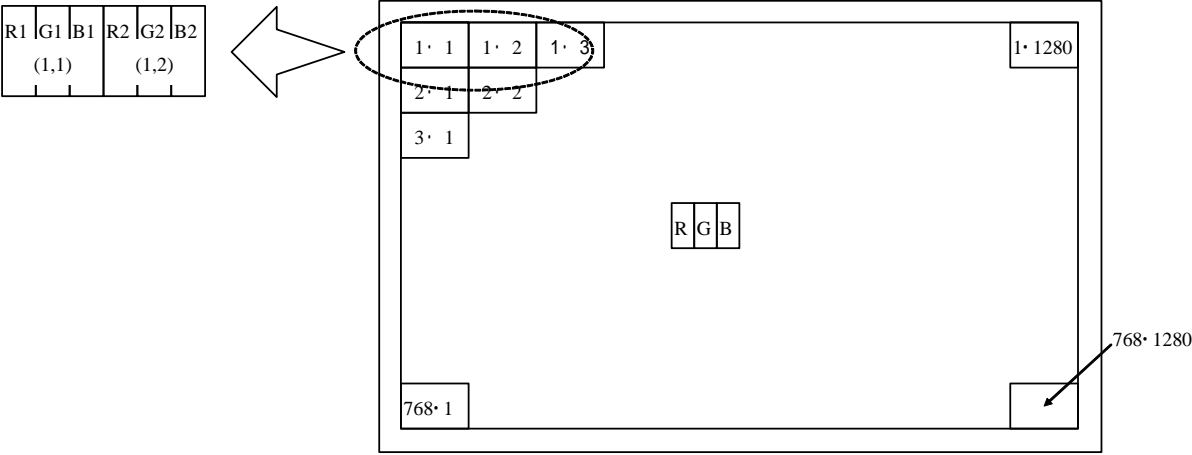

Display position of input data(V · H)

8. Input Signals, Basic Display Colors and Gray Scale of Each Color

Colors & Gray scale	Data signal																			
	Gray Scale	R0	R1	R2	R3	R4	R5	G0	G1	G2	G3	G4	G5	B0	B1	B2	B3	B4	B5	
Basic Color	Black	-	0	0	0	0	0	0	0	0	0	0	0	0	0	0	0	0	0	0
	Blue	-	0	0	0	0	0	0	0	0	0	0	0	0	1	1	1	1	1	1
	Green	-	0	0	0	0	0	0	1	1	1	1	1	1	0	0	0	0	0	0
	Cyan	-	0	0	0	0	0	0	1	1	1	1	1	1	1	1	1	1	1	1
	Red	-	1	1	1	1	1	1	0	0	0	0	0	0	0	0	0	0	0	0
	Magenta	-	1	1	1	1	1	1	0	0	0	0	0	0	1	1	1	1	1	1
	Yellow	-	1	1	1	1	1	1	1	1	1	1	1	1	0	0	0	0	0	0
	White	-	1	1	1	1	1	1	1	1	1	1	1	1	1	1	1	1	1	1
Gray Scale of Red	Black	GS0	0	0	0	0	0	0	0	0	0	0	0	0	0	0	0	0	0	0
	Darker	GS1	1	0	0	0	0	0	0	0	0	0	0	0	0	0	0	0	0	0
		GS2	0	1	0	0	0	0	0	0	0	0	0	0	0	0	0	0	0	0
	Brighter	GS61	1	0	1	1	1	1	0	0	0	0	0	0	0	0	0	0	0	0
		GS62	0	1	1	1	1	1	0	0	0	0	0	0	0	0	0	0	0	0
	Red	GS63	1	1	1	1	1	1	0	0	0	0	0	0	0	0	0	0	0	0
Gray Scale of Green	Black	GS0	0	0	0	0	0	0	0	0	0	0	0	0	0	0	0	0	0	0
	Darker	GS1	0	0	0	0	0	0	1	0	0	0	0	0	0	0	0	0	0	0
		GS2	0	0	0	0	0	0	0	1	0	0	0	0	0	0	0	0	0	0
	Brighter	GS61	0	0	0	0	0	0	1	0	1	1	1	1	0	0	0	0	0	0
		GS62	0	0	0	0	0	0	0	1	1	1	1	1	0	0	0	0	0	0
	Green	GS63	0	0	0	0	0	0	1	1	1	1	1	1	0	0	0	0	0	0
Gray Scale of Blue	Black	GS0	0	0	0	0	0	0	0	0	0	0	0	0	0	0	0	0	0	0
	Darker	GS1	0	0	0	0	0	0	0	0	0	0	0	0	1	0	0	0	0	0
		GS2	0	0	0	0	0	0	0	0	0	0	0	0	0	1	0	0	0	0
	Brighter	GS61	0	0	0	0	0	0	0	0	0	0	0	0	1	0	1	1	1	1
		GS62	0	0	0	0	0	0	0	0	0	0	0	0	0	1	1	1	1	1
	Blue	GS63	0	0	0	0	0	0	0	0	0	0	0	0	1	1	1	1	1	1

0 : Low level voltage, 1 : High level voltage

Each basic color can be displayed in 64 gray scales from 6 bit data signals. According to the combination of total 18 bit data signals, the 262,144-color display can be achieved on the screen.

9. Optical Characteristics

Ta=+25 , Vcc=+3.3V

Parameter		Symbol	Condition	Min.	Typ.	Max.	Unit	Remark
Viewing angle range	Horizontal	21, 22	CR>10	60	70	-	Deg.	[Note 1,3,6]
	Vertical	11		40	50	-	Deg.	
		12		50	60	-	Deg.	
Contrast ratio		CRn	=0 °	150	-	-		[Note 2,4,6]
		CRo	Optimum viewing angle	150	350	-		
Response time		r+ d	=0 °	-	35	-	ms	[Note 2,5,6]
Chromaticity of white		x		0.263	0.313	0.363		[Note 2,6]
		y		0.279	0.329	0.379		
Luminance of white		Y _{LI}		210	280	-	cd/m ²	I _f =17mA [Note 2,7]
White Uniformity		w		-	-	1.45		[Note 2,8]

The measurement shall be executed 30 minutes after lighting at rating. Condition : (I_f=17mA)
 The optical characteristics shall be measured in a dark room or equivalent.

[Note 1] Measuring Viewing Angle Range

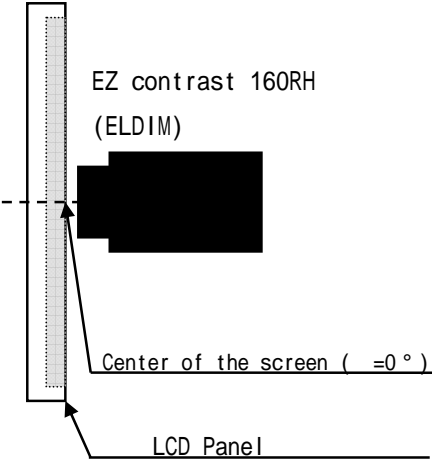

[Note 2] Other Measurements

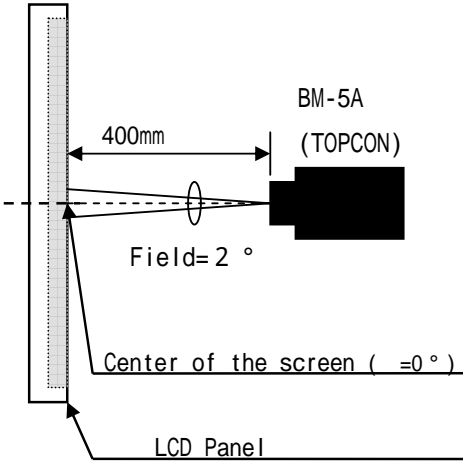

[Note 3] Definitions of viewing angle range:

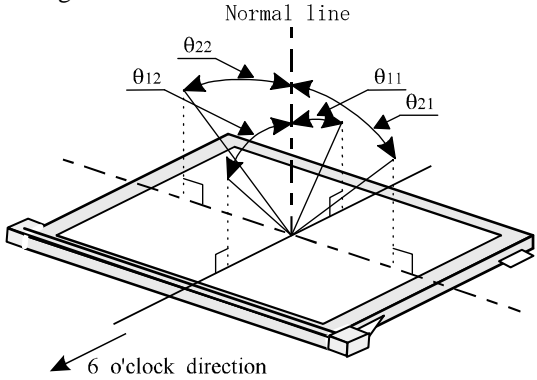

[Note 4] Definition of contrast ratio:

The contrast ratio is defined as the following.

$$\text{Contrast Ratio (CR)} = \frac{\text{Luminance (brightness) with all pixels white}}{\text{Luminance (brightness) with all pixels black}}$$

[Note 5] Definition of response time:

The response time is defined as the following figure and shall be measured by switching the input signal for "black" and "white" .

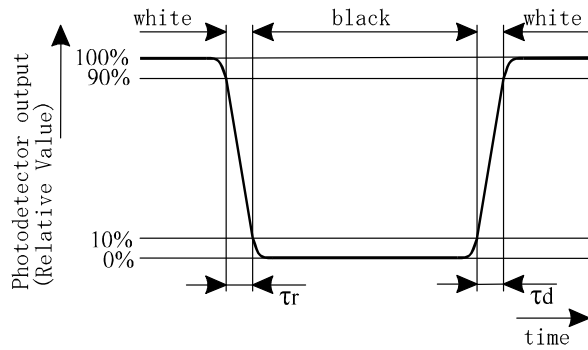

[Note 6] This shall be measured at center of the screen.

[Note 7] Average of five point.(A~E)

[Note 8] Definition of white uniformity:

White uniformity is defined as the following with five measurements (A ~ E).

$$w = \frac{\text{Maximum Luminance of five points (brightness)}}{\text{Minimum Luminance of five points (brightness)}}$$

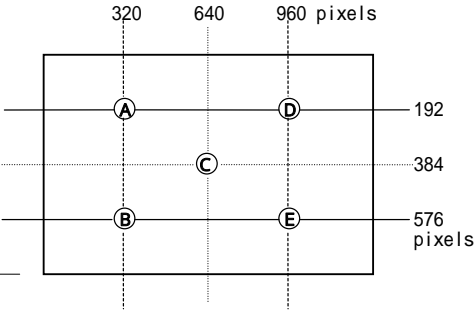

10. Display Quality

The display quality of the color TFT-LCD module shall be in compliance with the Incoming Inspection Standard.

11 . Handling Precautions

- a) Be sure to turn off the power supply when inserting or disconnecting the cable.
- b) Be sure to design the cabinet so that the module can be installed without any extra stress such as warp or twist.
- c) Since the front polarizer is easily damaged, pay attention not to scratch it.
- d) Wipe off water drop immediately. Long contact with water may cause discoloration or spots.
- e) When the panel surface is soiled, wipe it with absorbent cotton or other soft cloth.
- f) Since the panel is made of glass, it may break or crack if dropped or bumped on hard surface. Handle with care.
- g) Since CMOS LSI is used in this module, take care of static electricity and injure the human earth when handling.
Observe all other precautionary requirements in handling components.
- h) This module has its circuitry PCBs on the rear side and should be handled carefully in order not to be stressed.
- i) Protect sheet is attached to the module surface to prevent it from being scratched. Peel the sheet off slowly just before the use with strict attention to electrostatic charges. Ionized air shall be blown over during the action.
Blow off the 'dust' on the polarizer by using an ionized nitrogen gun, etc..
- j) Do not expose the LCD module to a direct sunlight, for a long period of time to protect the module from the ultra violet ray.
- k) Connect GND of mounting holes to stabilize against EMI and external noise.
- l) When handling LCD modules and assembling them into cabinets, please be noted that long-term storage in the environment of oxidization or deoxidization gas and the use of such materials as reagent, solvent, adhesive, resin, etc. which generate these gasses, may cause corrosion and discoloration of the LCD modules.
- m) Adjusting volume have been set optimally before shipment, so do not change any adjusted value. If adjusted value is changed, the specification may not be satisfied.
- n) Disassembling the module can cause permanent damage and should be strictly avoided.
- o) Please be careful since image retention may occur when a fixed pattern is displayed for a long time.

12. Packing Form

Piling number of cartons	Max.6
Package quantity in one carton	20 pcs
Carton size	397(W)×313(D)×303(H) mm
Total mass of one carton filled with full modules	5.0kg
Packing form	Fig1

13. Reliability Test Items

No.	Test item	Conditions
1	High temperature operation test	Ta = +50 240h (Panel-surface temperature is +60 Max.)
2	Low temperature operation test	Ta = 0 240h
3	High temperature storage test	Ta = +60 240h
4	Low temperature storage test	Ta = -20 240h
5	High temperature & high humidity operation test	Ta = +40 ; 90 %RH 240h (No condensation)
6	Shock test (non- operating)	Max. gravity : 490 m/s ² Pulse width : 11 ms, sine wave Direction : ± X, ± Y, ± Z once for each direction.
7	Vibration test (non- operating)	Frequency : 10 ~ 57Hz/Vibration width (one side):0.075mm : 57 ~ 500Hz/Gravity:9.8m/s ² Sweep time : 11 minutes Test period : 3 hours (1 hour for each direction of X,Y,Z)

[Result Evaluation Criteria] Under the display quality test conditions with normal operation state, these shall be no change, which may affect practical display function.

[Normal operation state] Temperature : +15 ~ +35 , Humidity : 45 ~ 75%, Atmospheric pressure : 86 ~ 106kPa

14. Label

1) Module Bar code label:

Notation: Model No. SHARP Logo. Manufacture country Serial No.
 Bar code: Model No. Serial No. Patent No.

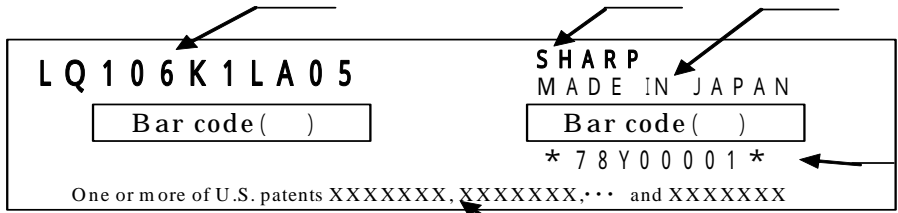

Serial No.

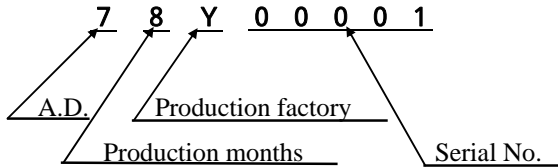

Production factory
 Y : YAMATO Electric Company
 S : K Technology Corporation

(Production months)
 1-9(Jan.-Sep.),X(Oct.),Y(Nov.),Z(Dec)

2) Packing bar code label

Notation/ Bar code: Model No. Date Quantity

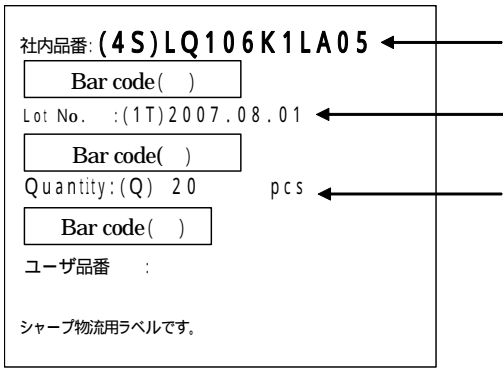

15. RoHS Regulations

This LCD module is compliant with RoHS Directive.

Carton mark

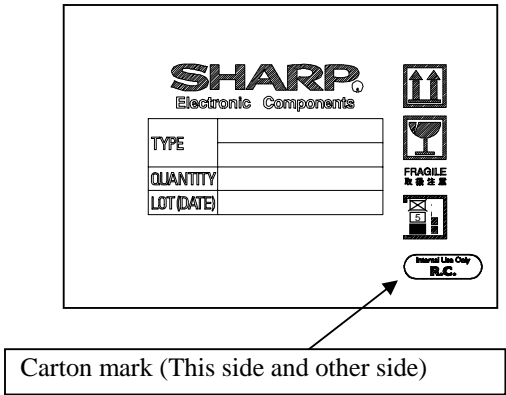

Carton mark (This side and other side)

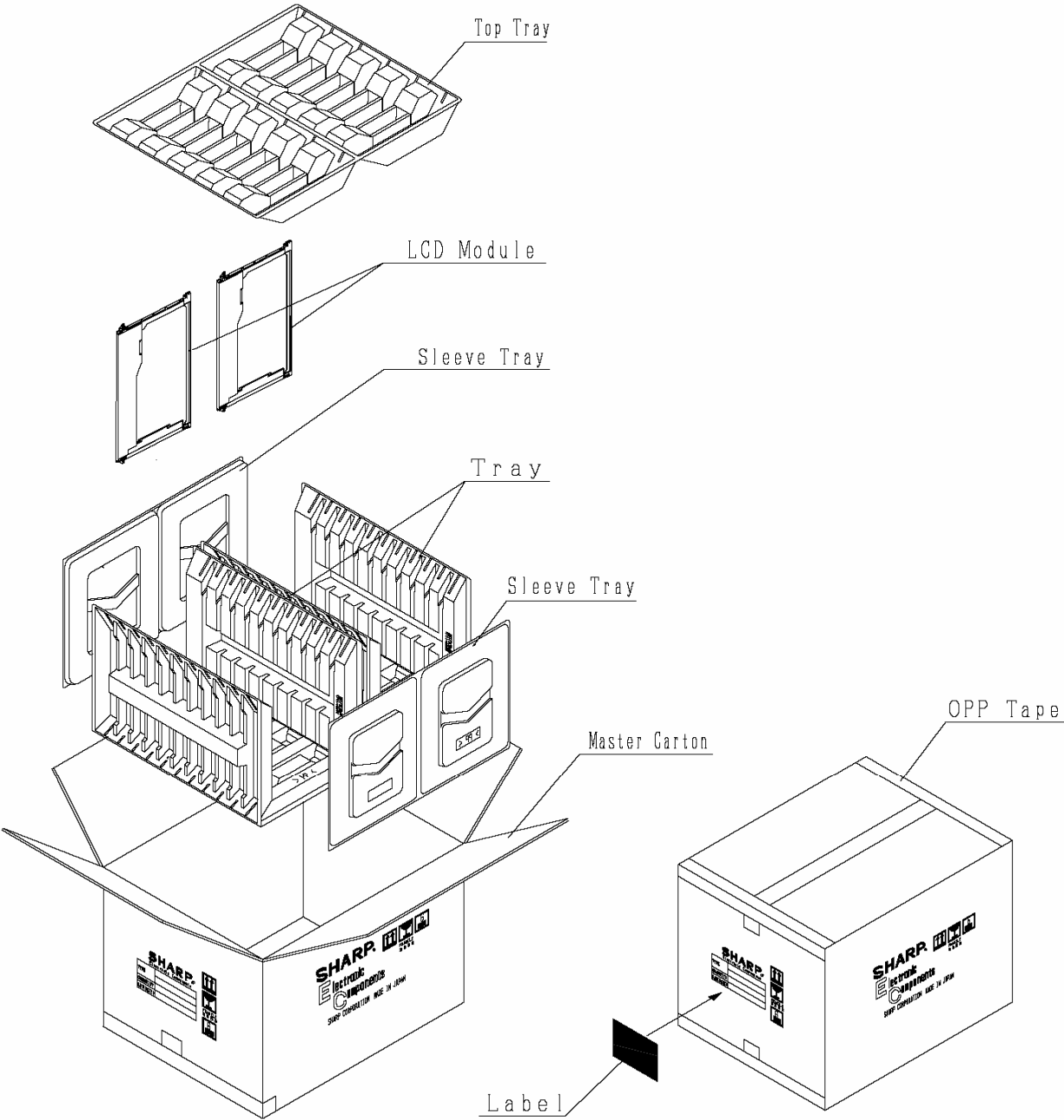
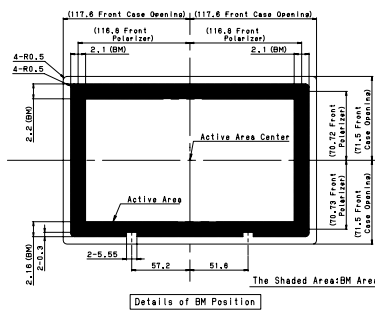
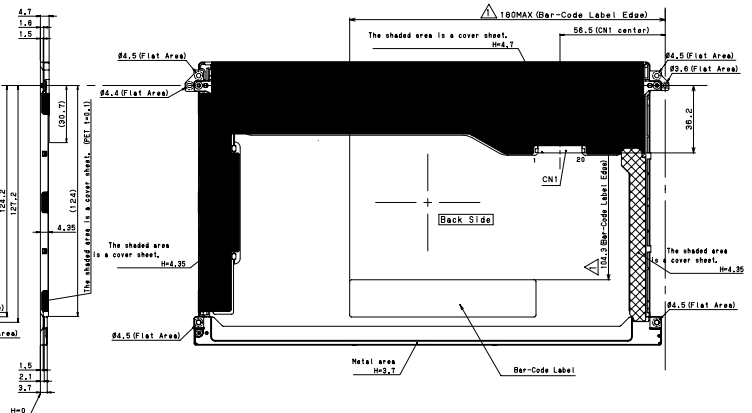
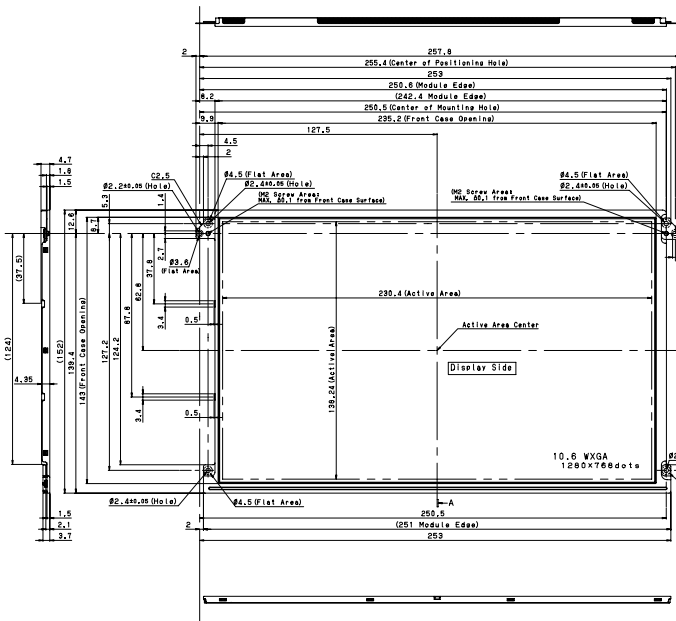
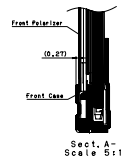

Fig1 Packing Form



BM: Abbreviation of Black Mask
 BM S11: Non-BM Area on Liquid Crystal Inlet



CONNECTORS
 CN1: INTERFACE CONNECTOR
 DF19L-20P-1H (HIROSE)

- NOTES**
- 1) General tolerance is 0.5, excepting general tolerance of thickness is 0.3.
 - 2) The module thickness are exclude warp and float of cover sheet, PMD and frame.
 - 3) Stress on cover sheet break down the electronic parts. (A shaded area.)
 - 4) Guarantee of appearance = LCD Active Area
 - 5) Stress on front case side makes transformation and warp of front case opening area.
 - 6) The light of Back Light is leaking from BM outside, please light shielding by the set. (See "Details of BM Position" on left side.)

LCD Specification

LCD Group



NORTH AMERICA

Sharp Microelectronics of the Americas
5700 NW Pacific Rim Blvd.
Camas, WA 98607, U.S.A.
Phone: (1) 360-834-2500
Fax: (1) 360-834-8903
www.sharpsma.com

TAIWAN

Sharp Electronic Components
(Taiwan) Corporation
8F-A, No. 16, Sec. 4, Nanking E. Rd.
Taipei, Taiwan, Republic of China
Phone: (886) 2-2577-7341
Fax: (886) 2-2577-7326/2-2577-7328

CHINA

Sharp Microelectronics of China
(Shanghai) Co., Ltd.
28 Xin Jin Qiao Road King Tower 16F
Pudong Shanghai, 201206 P.R. China
Phone: (86) 21-5854-7710/21-5834-6056
Fax: (86) 21-5854-4340/21-5834-6057
Head Office:
No. 360, Bashen Road,
Xin Development Bldg. 22
Waigaoqiao Free Trade Zone Shanghai
200131 P.R. China
Email: smc@china.global.sharp.co.jp

EUROPE

Sharp Microelectronics Europe
Division of Sharp Electronics (Europe) GmbH
Sonninstrasse 3
20097 Hamburg, Germany
Phone: (49) 40-2376-2286
Fax: (49) 40-2376-2232
www.sharpsme.com

SINGAPORE

Sharp Electronics (Singapore) PTE., Ltd.
438A, Alexandra Road, #05-01/02
Alexandra Technopark,
Singapore 119967
Phone: (65) 271-3566
Fax: (65) 271-3855

KOREA

Sharp Electronic Components
(Korea) Corporation
RM 501 Geosung B/D, 541
Dohwa-dong, Mapo-ku
Seoul 121-701, Korea
Phone: (82) 2-711-5813 ~ 8
Fax: (82) 2-711-5819

JAPAN

Sharp Corporation
Electronic Components & Devices
22-22 Nagaïke-cho, Abeno-Ku
Osaka 545-8522, Japan
Phone: (81) 6-6621-1221
Fax: (81) 6117-725300/6117-725301
www.sharp-world.com

HONG KONG

Sharp-Roxy (Hong Kong) Ltd.
3rd Business Division,
17/F, Admiralty Centre, Tower 1
18 Harcourt Road, Hong Kong
Phone: (852) 28229311
Fax: (852) 28660779
www.sharp.com.hk
Shenzhen Representative Office:
Room 13B1, Tower C,
Electronics Science & Technology Building
Shen Nan Zhong Road
Shenzhen, P.R. China
Phone: (86) 755-3273731
Fax: (86) 755-3273735

SPECIFICATIONS ARE SUBJECT TO CHANGE WITHOUT NOTICE.

Suggested applications (if any) are for standard use; See Important Restrictions for limitations on special applications. See Limited Warranty for SHARP's product warranty.

The Limited Warranty is in lieu, and exclusive of, all other warranties, express or implied.

ALL EXPRESS AND IMPLIED WARRANTIES, INCLUDING THE WARRANTIES OF MERCHANTABILITY, FITNESS FOR USE AND FITNESS FOR A PARTICULAR PURPOSE, ARE SPECIFICALLY EXCLUDED. In no event will SHARP be liable, or responsible in any way, for any incidental or consequential economic or property damage.