

1. Features

- Low capacitance (0.5pF Typ.)
- Protection for the IEC61000-4-2(ESD) $\pm 10\text{kV}$ (contact), $\pm 15\text{kV}$ (air)
- Fast turn on and low clamping voltage
- For 4 lines

2. Typical Applications

- High Speed Communication Line Protection
- HDMI, Display Port, SATA, USB2.0x2 ports, etc.

3. Mechanical details (dimensions: mm)

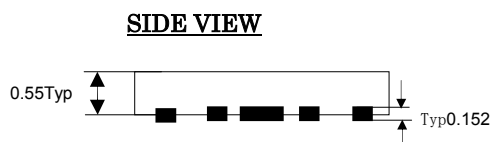
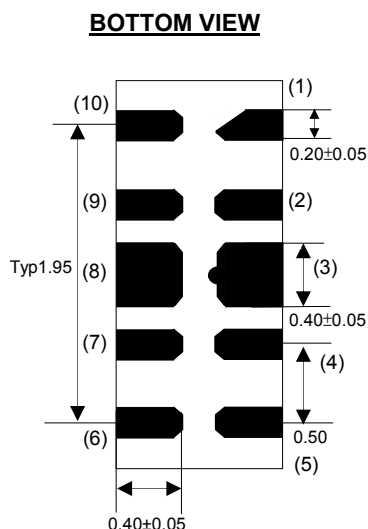
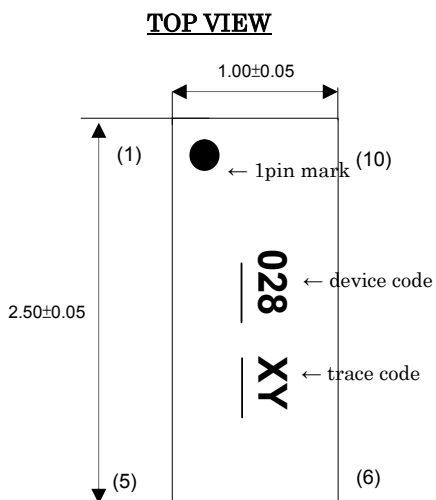

No	Terminal Name
(1)	Line-1
(2)	Line-2
(3)	GND
(4)	Line-3
(5)	Line-4
(6)	NC
(7)	NC
(8)	GND
(9)	NC
(10)	NC

4. Schematic

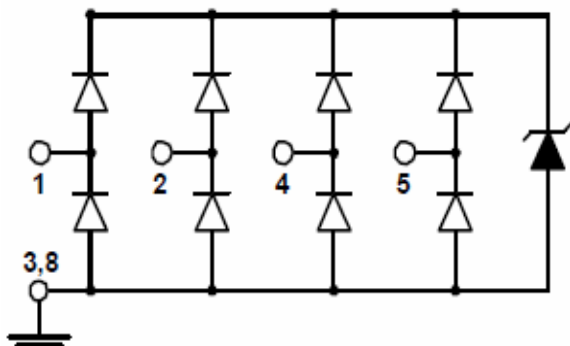

5. Maximum Ratings

Rating	Symbol	Value	Units
Operating Voltage(VDD-GND)	V_{DC}	6	V
ESD per IEC 61000-4-2 (air)	V_{ESD}	±15	kV
ESD per IEC 61000-4-2 (contact)		±10	
Lead Soldering Temperature	T_{SOL}	260(10sec.)	°C
Operating Temperature	T_{OP}	-40 to +85	°C
Storage Temperature	T_{STO}	-40 to +125	°C

6. Electrical characteristics (T=25 °C)

Parameter	Symbol	Conditions	Min	Typ	Max	Units
Leakage Current	I_{Leak}	$V_{pin3,8}=0V, V_{pin1,2,4,5}=0-5V$			1.5	µA
Breakdown Voltage	V_{BV}	$I_{BV} = 1mA$	6		10	V
Capacitance (I/O-GND)	C_{IN}	$V_{pin3,8}=0V, V_{in}=2.5V, f=1MHz,$		0.5		pF

7. Typical Characteristic

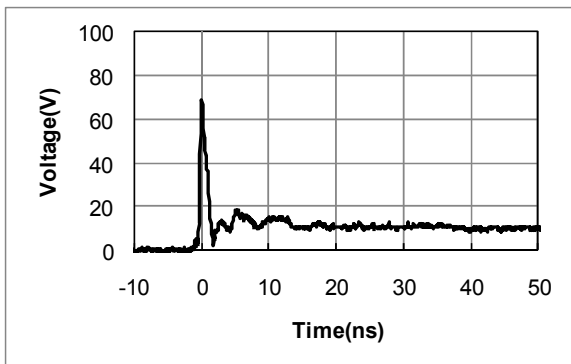

ESD Waveform (IEC61000-4-2:8kV Contact)

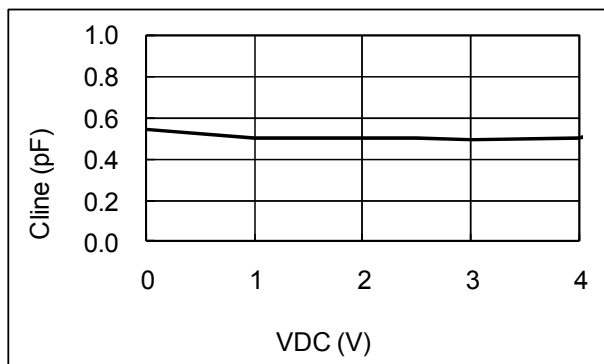

Voltage – Capacitance Characteristic

8. Soldering Footprint (dimensions: mm)

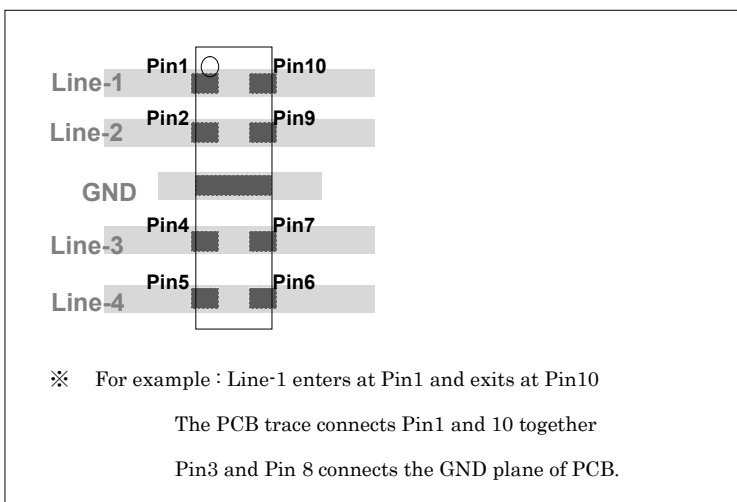
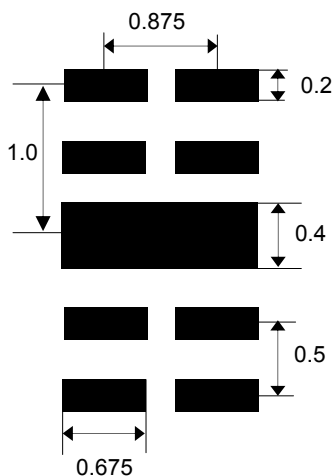

Notes : this land layout is for preference purpose only.

9. Taping Specification

1) Dimensions of Tape (Plastic tape)

(in mm)

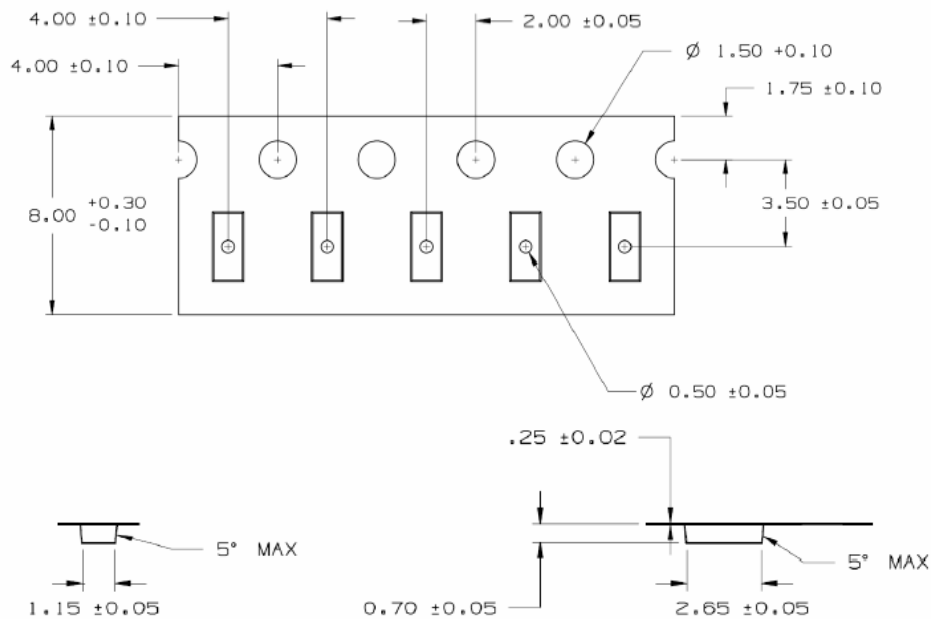

2) Dimensions of Reel

(in mm)

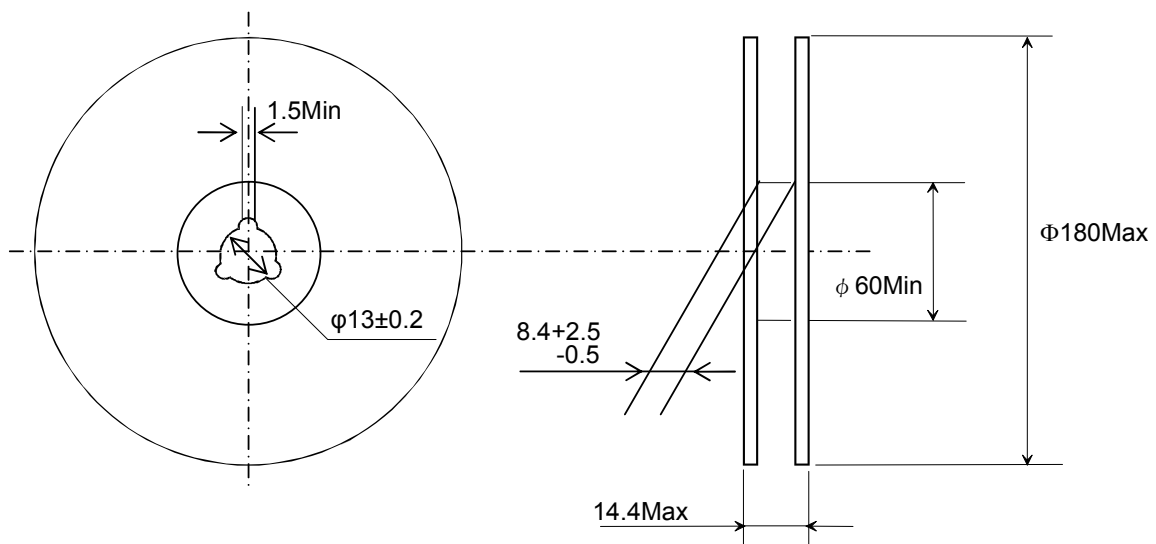

3) Packaging unit: 3,000 pcs / reel